

## Field Drilling of Nordic Lam+ Beams

This technical note provides guidelines for field drilling of small horizontal holes in Nordic Lam+ beams.

The holes must conform to the following geometries:

### 1. Hole size:

- Case A (see below): The hole diameter should not exceed 1-1/2 inch or 1/10 the beam depth, whichever is smaller.
- Case B (see below): The hole diameter should not exceed 1 inch or 1/10 the beam depth, whichever is smaller.

- Hole location:** The hole should have a minimum clear distance, as measured from the edge of the hole to the nearest edge of the beam, of 4 hole diameters to the top or bottom face of the beam and 8 hole diameters from the end of the beam. Note that the horizontal hole should be drilled in the zones shown below.
- Hole spacing:** The minimum clear spacing between adjacent holes, as measured between the nearest edge of the holes, should be 8 hole diameters based on the largest diameter of any adjacent hole.
- Number of holes:** The maximum number of holes should not exceed 1 hole per 5 feet of beam length. The hole spacing limitation given above should be satisfied separately.

### Case A

- Simple-span, uniformly loaded beam only
- Hole diameter  $d \leq 1\text{-}1/2$  in. (38 mm) and  $\leq h/10$

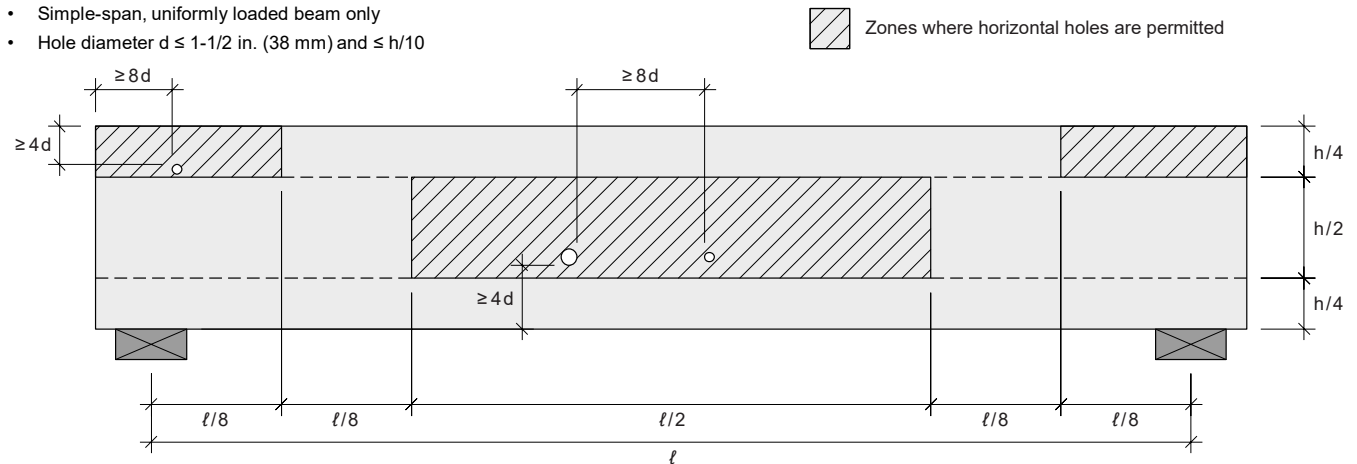

### Case B

- Simple- or multiple-span, uniformly loaded beam only
- Beam height  $h \geq 7\text{-}1/4$  in. (185 mm)
- Hole diameter  $d \leq 1$  in. (25 mm) and  $\leq h/10$

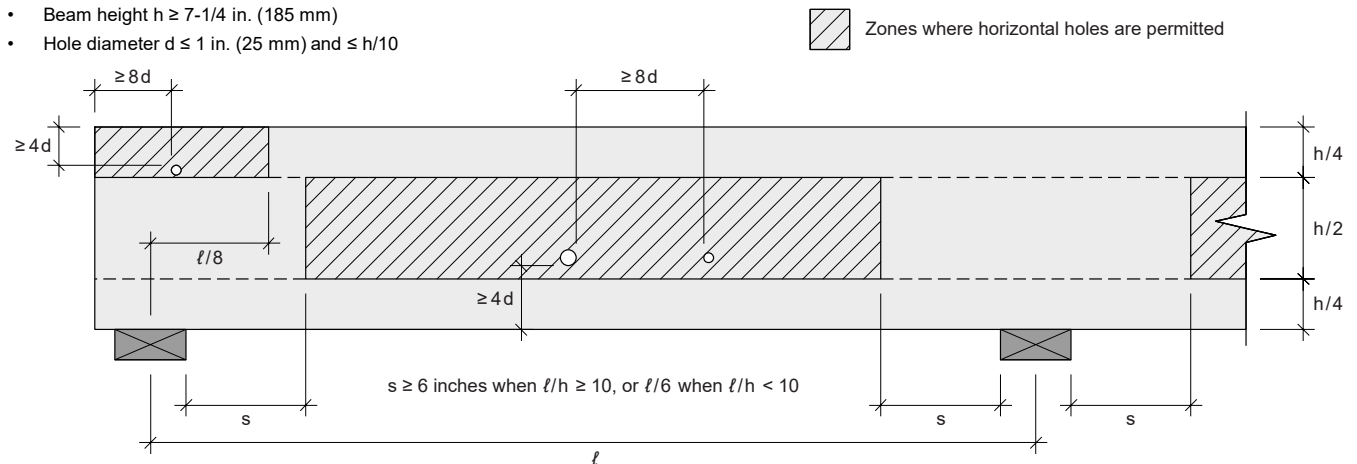

### Notes:

1. For glulam members that have been oversized, the guidelines given above may be relaxed based on an engineering analysis.
2. Field-drilled horizontal holes should be used for access only (i.e. for the passage of wires, electrical conduits, and other small, lightweight materials) and should not be used as load bearing attachment points.