

Portées maximales de plancher – Blocage à mi-portée

Notes générales

1. Les portées indiquées dans les tableaux peuvent légèrement différer des logiciels de calcul.
2. Il est préférable d'utiliser un logiciel de calcul pour refléter les conditions réelles (portée(s), charges, composition de plancher, etc.). Autrement, d'autres tableaux sont disponibles sur demande.

Index

Numéro	Surcharge (lbf/pi ²)	Charge permanente (lbf/pi ²)	Portées	Limite de flèche	Système de plancher	Revêtement	
						Épaisseur (po)	Type
S1.1	40	15	Simple	L/480 ou L/360	Cloué et collé	19/32	OSB
S1.2	40	15	Multiple	L/480 ou L/360	Cloué et collé	19/32	OSB
S2.1	40	15	Simple	L/480 ou L/360	Cloué et collé	5/8	OSB
S2.2	40	15	Multiple	L/480 ou L/360	Cloué et collé	5/8	OSB
S3.1	40	15	Simple	L/480 ou L/360	Cloué et collé	23/32	OSB
S3.2	40	15	Multiple	L/480 ou L/360	Cloué et collé	23/32	OSB
S4.1	40	15	Simple	L/480 ou L/360	Cloué et collé	3/4	OSB
S4.2	40	15	Multiple	L/480 ou L/360	Cloué et collé	3/4	OSB
S5.1	40	15	Simple	L/480 ou L/360	Cloué et collé	7/8	OSB
S5.2	40	15	Multiple	L/480 ou L/360	Cloué et collé	7/8	OSB
S6.1	40	15	Simple	L/480 ou L/360	Cloué et collé	5/8	Contreplaqué
S6.2	40	15	Multiple	L/480 ou L/360	Cloué et collé	5/8	Contreplaqué
S7.1	40	15	Simple	L/480 ou L/360	Cloué et collé	3/4	Contreplaqué
S7.2	40	15	Multiple	L/480 ou L/360	Cloué et collé	3/4	Contreplaqué
M1.1	40	20	Simple	L/480 ou L/360	Cloué et collé	19/32	OSB
M1.2	40	20	Multiple	L/480 ou L/360	Cloué et collé	19/32	OSB
M2.1	40	20	Simple	L/480 ou L/360	Cloué et collé	5/8	OSB
M2.2	40	20	Multiple	L/480 ou L/360	Cloué et collé	5/8	OSB
M3.1	40	20	Simple	L/480 ou L/360	Cloué et collé	23/32	OSB
M3.2	40	20	Multiple	L/480 ou L/360	Cloué et collé	23/32	OSB
M4.1	40	20	Simple	L/480 ou L/360	Cloué et collé	3/4	OSB
M4.2	40	20	Multiple	L/480 ou L/360	Cloué et collé	3/4	OSB
M5.1	40	20	Simple	L/480 ou L/360	Cloué et collé	7/8	OSB
M5.2	40	20	Multiple	L/480 ou L/360	Cloué et collé	7/8	OSB
M6.1	40	20	Simple	L/480 ou L/360	Cloué et collé	5/8	Contreplaqué
M6.2	40	20	Multiple	L/480 ou L/360	Cloué et collé	5/8	Contreplaqué
M7.1	40	20	Simple	L/480 ou L/360	Cloué et collé	3/4	Contreplaqué
M7.2	40	20	Multiple	L/480 ou L/360	Cloué et collé	3/4	Contreplaqué
H1.1	40	35	Simple	L/480 ou L/360	Cloué et collé	19/32	OSB
H1.2	40	35	Multiple	L/480 ou L/360	Cloué et collé	19/32	OSB
H2.1	40	35	Simple	L/480 ou L/360	Cloué et collé	5/8	OSB
H2.2	40	35	Multiple	L/480 ou L/360	Cloué et collé	5/8	OSB
H3.1	40	35	Simple	L/480 ou L/360	Cloué et collé	23/32	OSB
H3.2	40	35	Multiple	L/480 ou L/360	Cloué et collé	23/32	OSB
H4.1	40	35	Simple	L/480 ou L/360	Cloué et collé	3/4	OSB
H4.2	40	35	Multiple	L/480 ou L/360	Cloué et collé	3/4	OSB
H5.1	40	35	Simple	L/480 ou L/360	Cloué et collé	7/8	OSB
H5.2	40	35	Multiple	L/480 ou L/360	Cloué et collé	7/8	OSB
H6.1	40	35	Simple	L/480 ou L/360	Cloué et collé	5/8	Contreplaqué
H6.2	40	35	Multiple	L/480 ou L/360	Cloué et collé	5/8	Contreplaqué
H7.1	40	35	Simple	L/480 ou L/360	Cloué et collé	3/4	Contreplaqué
H7.2	40	35	Multiple	L/480 ou L/360	Cloué et collé	3/4	Contreplaqué

Portées maximales de plancher – Blocage à mi-portée (suite)

Compositions de plancher

Solive seule

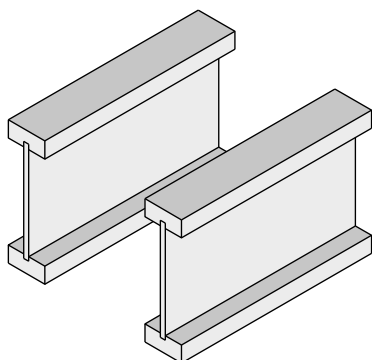

Blocage à mi-portée

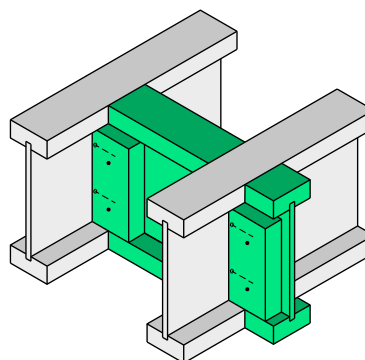

Portées maximales de plancher – S1.1, blocage à mi-portée

Critères de conception

Portées :	Portée simple
Charges :	Surcharge = 40 lbf/pi ² et charge permanente = 15 lbf/pi ²
Limite de flèche :	L/240 sous la charge totale
Revêtement :	Panneaux de copeaux orientés (OSB) 19/32 po, cloué et collé

Portées maximales de plancher

Limite de flèche de L/480 sous la surcharge

Hauteur	Série	Solive seule				Blocage à mi-portée			
		Espacement centre/centre				Espacement centre/centre			
		12"	16"	19,2"	24"	12"	16"	19,2"	24"
9-1/2"	NI-20	14'-11"	14'-1"	13'-7"	-	15'-10"	15'-0"	14'-4"	-
	NI-40x	15'-11"	15'-0"	14'-6"	-	16'-11"	16'-0"	15'-6"	-
	NI-60	16'-1"	15'-2"	14'-8"	-	17'-1"	16'-1"	15'-7"	-
	NI-80	17'-0"	16'-0"	15'-6"	-	18'-0"	17'-0"	16'-5"	-
11-7/8"	NI-20	16'-9"	15'-10"	15'-4"	-	17'-11"	17'-0"	16'-6"	-
	NI-40x	17'-10"	16'-10"	16'-3"	-	19'-5"	18'-0"	17'-5"	-
	NI-60	18'-1"	17'-0"	16'-5"	-	19'-8"	18'-3"	17'-7"	-
	NI-80	19'-5"	17'-11"	17'-4"	-	21'-0"	19'-6"	18'-8"	-
	NI-90	19'-10"	18'-4"	17'-7"	-	21'-5"	19'-11"	19'-0"	-
14"	NI-40x	19'-9"	18'-4"	17'-8"	-	21'-8"	20'-1"	19'-4"	-
	NI-60	20'-1"	18'-7"	17'-10"	-	22'-0"	20'-5"	19'-7"	-
	NI-80	21'-7"	19'-11"	19'-1"	-	23'-6"	21'-10"	20'-10"	-
	NI-90	22'-0"	20'-4"	19'-5"	-	24'-0"	22'-3"	21'-3"	-
16"	NI-60	21'-11"	20'-4"	19'-5"	-	24'-2"	22'-5"	21'-6"	-
	NI-80	23'-6"	21'-9"	20'-9"	-	25'-10"	23'-11"	22'-10"	-
	NI-90	23'-11"	22'-1"	21'-2"	-	26'-3"	24'-4"	23'-3"	-

Limite de flèche de L/360 sous la surcharge

Hauteur	Série	Solive seule				Blocage à mi-portée			
		Espacement centre/centre				Espacement centre/centre			
		12"	16"	19,2"	24"	12"	16"	19,2"	24"
9-1/2"	NI-20	14'-11"	14'-1"	13'-7"	-	15'-10"	15'-0"	14'-6"	-
	NI-40x	15'-11"	15'-0"	14'-6"	-	16'-11"	16'-0"	15'-6"	-
	NI-60	16'-1"	15'-2"	14'-8"	-	17'-1"	16'-1"	15'-7"	-
	NI-80	17'-0"	16'-0"	15'-6"	-	18'-0"	17'-0"	16'-5"	-
11-7/8"	NI-20	16'-9"	15'-10"	15'-4"	-	17'-11"	17'-0"	16'-6"	-
	NI-40x	17'-10"	16'-10"	16'-3"	-	19'-5"	18'-0"	17'-5"	-
	NI-60	18'-1"	17'-0"	16'-5"	-	19'-8"	18'-3"	17'-7"	-
	NI-80	19'-5"	17'-11"	17'-4"	-	21'-0"	19'-6"	18'-8"	-
	NI-90	19'-10"	18'-4"	17'-7"	-	21'-5"	19'-11"	19'-0"	-
14"	NI-40x	19'-9"	18'-4"	17'-8"	-	21'-8"	20'-1"	19'-4"	-
	NI-60	20'-1"	18'-7"	17'-10"	-	22'-0"	20'-5"	19'-7"	-
	NI-80	21'-7"	19'-11"	19'-1"	-	23'-6"	21'-10"	20'-10"	-
	NI-90	22'-0"	20'-4"	19'-5"	-	24'-0"	22'-3"	21'-3"	-
16"	NI-60	21'-11"	20'-4"	19'-5"	-	24'-2"	22'-5"	21'-6"	-
	NI-80	23'-6"	21'-9"	20'-9"	-	25'-10"	23'-11"	22'-10"	-
	NI-90	23'-11"	22'-1"	21'-2"	-	26'-3"	24'-4"	23'-3"	-

Notes :

1. Les portées libres indiquées sont basées sur la norme CSA O86-14 et le CNB 2015 et s'appliquent à la construction de planchers résidentiels respectant les critères de conception ci-dessus.
2. Pour les portées multiples, les portées extérieures doivent être supérieures à 40% de la portée adjacente.
3. La longueur d'appui minimale est de 1-3/4 pouce pour les appuis d'extrémités et de 3-1/2 pouces pour les appuis intermédiaires.
4. Les raidisseurs d'appui ne sont pas requis lorsque les solives sont utilisées conformément à ce tableau, sauf si requis pour les étriers.

Portées maximales de plancher – S1.2, blocage à mi-portée

Critères de conception

Portées :	Portées multiples
Charges :	Surcharge = 40 lbf/pi ² et charge permanente = 15 lbf/pi ²
Limite de flèche :	L/240 sous la charge totale
Revêtement :	Panneaux de copeaux orientés (OSB) 19/32 po, cloué et collé

Portées maximales de plancher

Limite de flèche de L/480 sous la surcharge

Hauteur	Série	Solive seule				Blocage à mi-portée			
		Espacement centre/centre				Espacement centre/centre			
		12"	16"	19,2"	24"	12"	16"	19,2"	24"
9-1/2"	NI-20	16'-0"	15'-2"	14'-8"	-	17'-0"	16'-1"	15'-8"	-
	NI-40x	17'-2"	16'-2"	15'-8"	-	18'-2"	17'-2"	16'-7"	-
	NI-60	17'-4"	16'-4"	15'-10"	-	18'-5"	17'-4"	16'-9"	-
	NI-80	18'-6"	17'-4"	16'-9"	-	19'-9"	18'-4"	17'-8"	-
11-7/8"	NI-20	18'-1"	17'-1"	16'-6"	-	19'-8"	18'-4"	17'-8"	-
	NI-40x	19'-8"	18'-3"	17'-7"	-	21'-3"	19'-9"	18'-11"	-
	NI-60	19'-11"	18'-6"	17'-9"	-	21'-6"	20'-0"	19'-2"	-
	NI-80	21'-5"	19'-10"	19'-0"	-	23'-1"	21'-5"	20'-6"	-
14"	NI-90	21'-11"	20'-3"	19'-4"	-	23'-7"	21'-10"	20'-11"	-
	NI-40x	21'-9"	20'-3"	19'-4"	-	23'-9"	22'-1"	21'-2"	-
	NI-60	22'-2"	20'-7"	19'-8"	-	24'-1"	22'-5"	21'-6"	-
	NI-80	23'-10"	22'-0"	21'-1"	-	25'-10"	23'-11"	22'-11"	-
16"	NI-90	24'-4"	22'-6"	21'-6"	-	26'-4"	24'-5"	23'-4"	-
	NI-60	24'-2"	22'-5"	21'-5"	-	26'-5"	24'-7"	23'-6"	-
	NI-80	26'-0"	24'-0"	22'-11"	-	28'-4"	26'-3"	25'-1"	-
	NI-90	26'-6"	24'-5"	23'-4"	-	28'-10"	26'-8"	25'-6"	-

Limite de flèche de L/360 sous la surcharge

Hauteur	Série	Solive seule				Blocage à mi-portée			
		Espacement centre/centre				Espacement centre/centre			
		12"	16"	19,2"	24"	12"	16"	19,2"	24"
9-1/2"	NI-20	16'-0"	15'-2"	14'-8"	-	17'-0"	16'-1"	15'-8"	-
	NI-40x	17'-2"	16'-2"	15'-8"	-	18'-2"	17'-2"	16'-7"	-
	NI-60	17'-4"	16'-4"	15'-10"	-	18'-5"	17'-4"	16'-9"	-
	NI-80	18'-6"	17'-4"	16'-9"	-	19'-9"	18'-4"	17'-8"	-
11-7/8"	NI-20	18'-1"	17'-1"	16'-6"	-	19'-8"	18'-4"	17'-8"	-
	NI-40x	19'-8"	18'-3"	17'-7"	-	21'-3"	19'-9"	18'-11"	-
	NI-60	19'-11"	18'-6"	17'-9"	-	21'-6"	20'-0"	19'-2"	-
	NI-80	21'-5"	19'-10"	19'-0"	-	23'-1"	21'-5"	20'-6"	-
14"	NI-90	21'-11"	20'-3"	19'-4"	-	23'-7"	21'-10"	20'-11"	-
	NI-40x	21'-9"	20'-3"	19'-4"	-	23'-9"	22'-1"	21'-2"	-
	NI-60	22'-2"	20'-7"	19'-8"	-	24'-1"	22'-5"	21'-6"	-
	NI-80	23'-10"	22'-0"	21'-1"	-	25'-10"	23'-11"	22'-11"	-
16"	NI-90	24'-4"	22'-6"	21'-6"	-	26'-4"	24'-5"	23'-4"	-
	NI-60	24'-2"	22'-5"	21'-5"	-	26'-5"	24'-7"	23'-6"	-
	NI-80	26'-0"	24'-0"	22'-11"	-	28'-4"	26'-3"	25'-1"	-
	NI-90	26'-6"	24'-5"	23'-4"	-	28'-10"	26'-8"	25'-6"	-

Notes :

1. Les portées libres indiquées sur la norme CSA O86-14 et le CNB 2015 et s'appliquent à la construction de planchers résidentiels respectant les critères de conception ci-dessus.
2. Pour les portées multiples, les portées extérieures doivent être supérieures à 40% de la portée adjacente.
3. La longueur d'appui minimale est de 1-3/4 pouce pour les appuis d'extrémités et de 3-1/2 pouces pour les appuis intermédiaires.
4. Les raidisseurs d'appui ne sont pas requis lorsque les solives sont utilisées conformément à ce tableau, sauf si requis pour les étriers.

Portées maximales de plancher – S2.1, blocage à mi-portée

Critères de conception

Portées :	Portée simple
Charges :	Surcharge = 40 lbf/pi ² et charge permanente = 15 lbf/pi ²
Limite de flèche :	L/240 sous la charge totale
Revêtement :	Panneaux de copeaux orientés (OSB) 5/8 po, cloué et collé

Portées maximales de plancher

Limite de flèche de L/480 sous la surcharge

Hauteur	Série	Solive seule				Blocage à mi-portée			
		Espacement centre/centre				Espacement centre/centre			
		12"	16"	19,2"	24"	12"	16"	19,2"	24"
9-1/2"	NI-20	15'-1"	14'-3"	13'-10"	-	16'-1"	15'-2"	14'-5"	-
	NI-40x	16'-2"	15'-3"	14'-8"	-	17'-1"	16'-2"	15'-8"	-
	NI-60	16'-4"	15'-4"	14'-10"	-	17'-3"	16'-4"	15'-9"	-
	NI-80	17'-3"	16'-3"	15'-8"	-	18'-3"	17'-2"	16'-7"	-
11-7/8"	NI-20	17'-0"	16'-0"	15'-6"	-	18'-2"	17'-2"	16'-7"	-
	NI-40x	18'-2"	17'-1"	16'-6"	-	19'-8"	18'-3"	17'-7"	-
	NI-60	18'-5"	17'-3"	16'-8"	-	19'-11"	18'-6"	17'-9"	-
	NI-80	19'-9"	18'-3"	17'-7"	-	21'-4"	19'-9"	18'-11"	-
14"	NI-90	20'-2"	18'-8"	17'-10"	-	21'-9"	20'-2"	19'-3"	-
	NI-40x	20'-1"	18'-8"	17'-10"	-	21'-11"	20'-5"	19'-6"	-
	NI-60	20'-6"	18'-11"	18'-2"	-	22'-3"	20'-8"	19'-10"	-
	NI-80	21'-11"	20'-3"	19'-4"	-	23'-10"	22'-1"	21'-1"	-
16"	NI-90	22'-5"	20'-8"	19'-9"	-	24'-4"	22'-6"	21'-6"	-
	NI-60	22'-4"	20'-8"	19'-9"	-	24'-5"	22'-8"	21'-8"	-
	NI-80	23'-11"	22'-1"	21'-1"	-	26'-2"	24'-2"	23'-1"	-
	NI-90	24'-5"	22'-6"	21'-6"	-	26'-7"	24'-8"	23'-6"	-

Limite de flèche de L/360 sous la surcharge

Hauteur	Série	Solive seule				Blocage à mi-portée			
		Espacement centre/centre				Espacement centre/centre			
		12"	16"	19,2"	24"	12"	16"	19,2"	24"
9-1/2"	NI-20	15'-1"	14'-3"	13'-10"	-	16'-1"	15'-2"	14'-6"	-
	NI-40x	16'-2"	15'-3"	14'-8"	-	17'-1"	16'-2"	15'-8"	-
	NI-60	16'-4"	15'-4"	14'-10"	-	17'-3"	16'-4"	15'-9"	-
	NI-80	17'-3"	16'-3"	15'-8"	-	18'-3"	17'-2"	16'-7"	-
11-7/8"	NI-20	17'-0"	16'-0"	15'-6"	-	18'-2"	17'-2"	16'-7"	-
	NI-40x	18'-2"	17'-1"	16'-6"	-	19'-8"	18'-3"	17'-7"	-
	NI-60	18'-5"	17'-3"	16'-8"	-	19'-11"	18'-6"	17'-9"	-
	NI-80	19'-9"	18'-3"	17'-7"	-	21'-4"	19'-9"	18'-11"	-
14"	NI-90	20'-2"	18'-8"	17'-10"	-	21'-9"	20'-2"	19'-3"	-
	NI-40x	20'-1"	18'-8"	17'-10"	-	21'-11"	20'-5"	19'-6"	-
	NI-60	20'-6"	18'-11"	18'-2"	-	22'-3"	20'-8"	19'-10"	-
	NI-80	21'-11"	20'-3"	19'-4"	-	23'-10"	22'-1"	21'-1"	-
16"	NI-90	22'-5"	20'-8"	19'-9"	-	24'-4"	22'-6"	21'-6"	-
	NI-60	22'-4"	20'-8"	19'-9"	-	24'-5"	22'-8"	21'-8"	-
	NI-80	23'-11"	22'-1"	21'-1"	-	26'-2"	24'-2"	23'-1"	-
	NI-90	24'-5"	22'-6"	21'-6"	-	26'-7"	24'-8"	23'-6"	-

Notes :

1. Les portées libres indiquées sur la norme CSA O86-14 et le CNB 2015 et s'appliquent à la construction de planchers résidentiels respectant les critères de conception ci-dessus.
2. Pour les portées multiples, les portées extérieures doivent être supérieures à 40% de la portée adjacente.
3. La longueur d'appui minimale est de 1-3/4 pouce pour les appuis d'extrémités et de 3-1/2 pouces pour les appuis intermédiaires.
4. Les raidisseurs d'appui ne sont pas requis lorsque les solives sont utilisées conformément à ce tableau, sauf si requis pour les étriers.

Portées maximales de plancher – S2.2, blocage à mi-portée

Critères de conception

Portées :	Portées multiples
Charges :	Surcharge = 40 lbf/pi ² et charge permanente = 15 lbf/pi ²
Limite de flèche :	L/240 sous la charge totale
Revêtement :	Panneaux de copeaux orientés (OSB) 5/8 po, cloué et collé

Portées maximales de plancher

Limite de flèche de L/480 sous la surcharge

Hauteur	Série	Solive seule Espacement centre/centre				Blocage à mi-portée Espacement centre/centre			
		12"	16"	19,2"	24"	12"	16"	19,2"	24"
9-1/2"	NI-20	16'-3"	15'-4"	14'-10"	-	17'-2"	16'-4"	15'-8"	-
	NI-40x	17'-5"	16'-5"	15'-10"	-	18'-5"	17'-4"	16'-9"	-
	NI-60	17'-7"	16'-7"	16'-0"	-	18'-8"	17'-6"	16'-11"	-
	NI-80	18'-10"	17'-6"	16'-11"	-	20'-1"	18'-8"	17'-10"	-
11-7/8"	NI-20	18'-5"	17'-3"	16'-9"	-	19'-11"	18'-7"	17'-10"	-
	NI-40x	20'-0"	18'-7"	17'-9"	-	21'-6"	20'-0"	19'-2"	-
	NI-60	20'-3"	18'-10"	18'-0"	-	21'-10"	20'-3"	19'-5"	-
	NI-80	21'-10"	20'-2"	19'-3"	-	23'-5"	21'-8"	20'-9"	-
14"	NI-90	22'-3"	20'-7"	19'-8"	-	23'-10"	22'-1"	21'-2"	-
	NI-40x	22'-2"	20'-7"	19'-8"	-	24'-0"	22'-4"	21'-5"	-
	NI-60	22'-7"	20'-11"	20'-0"	-	24'-5"	22'-8"	21'-9"	-
	NI-80	24'-3"	22'-5"	21'-5"	-	26'-2"	24'-3"	23'-2"	-
16"	NI-90	24'-9"	22'-10"	21'-10"	-	26'-8"	24'-9"	23'-7"	-
	NI-60	24'-7"	22'-10"	21'-9"	-	26'-10"	24'-11"	23'-10"	-
	NI-80	26'-5"	24'-5"	23'-4"	-	28'-8"	26'-7"	25'-4"	-
	NI-90	26'-11"	24'-11"	23'-9"	-	29'-3"	27'-1"	25'-10"	-

Limite de flèche de L/360 sous la surcharge

Hauteur	Série	Solive seule Espacement centre/centre				Blocage à mi-portée Espacement centre/centre			
		12"	16"	19,2"	24"	12"	16"	19,2"	24"
9-1/2"	NI-20	16'-3"	15'-4"	14'-10"	-	17'-2"	16'-4"	15'-9"	-
	NI-40x	17'-5"	16'-5"	15'-10"	-	18'-5"	17'-4"	16'-9"	-
	NI-60	17'-7"	16'-7"	16'-0"	-	18'-8"	17'-6"	16'-11"	-
	NI-80	18'-10"	17'-6"	16'-11"	-	20'-1"	18'-8"	17'-10"	-
11-7/8"	NI-20	18'-5"	17'-3"	16'-9"	-	19'-11"	18'-7"	17'-10"	-
	NI-40x	20'-0"	18'-7"	17'-9"	-	21'-6"	20'-0"	19'-2"	-
	NI-60	20'-3"	18'-10"	18'-0"	-	21'-10"	20'-3"	19'-5"	-
	NI-80	21'-10"	20'-2"	19'-3"	-	23'-5"	21'-8"	20'-9"	-
14"	NI-90	22'-3"	20'-7"	19'-8"	-	23'-10"	22'-1"	21'-2"	-
	NI-40x	22'-2"	20'-7"	19'-8"	-	24'-0"	22'-4"	21'-5"	-
	NI-60	22'-7"	20'-11"	20'-0"	-	24'-5"	22'-8"	21'-9"	-
	NI-80	24'-3"	22'-5"	21'-5"	-	26'-2"	24'-3"	23'-2"	-
16"	NI-90	24'-9"	22'-10"	21'-10"	-	26'-8"	24'-9"	23'-7"	-
	NI-60	24'-7"	22'-10"	21'-9"	-	26'-10"	24'-11"	23'-10"	-
	NI-80	26'-5"	24'-5"	23'-4"	-	28'-8"	26'-7"	25'-4"	-
	NI-90	26'-11"	24'-11"	23'-9"	-	29'-3"	27'-1"	25'-10"	-

Notes :

1. Les portées libres indiquées sont basées sur la norme CSA O86-14 et le CNB 2015 et s'appliquent à la construction de planchers résidentiels respectant les critères de conception ci-dessus.
2. Pour les portées multiples, les portées extérieures doivent être supérieures à 40% de la portée adjacente.
3. La longueur d'appui minimale est de 1-3/4 pouce pour les appuis d'extrémités et de 3-1/2 pouces pour les appuis intermédiaires.
4. Les raidisseurs d'appui ne sont pas requis lorsque les solives sont utilisées conformément à ce tableau, sauf si requis pour les étriers.

Portées maximales de plancher – S3.1, blocage à mi-portée

Critères de conception

Portées :	Portée simple
Charges :	Surcharge = 40 lbf/pi ² et charge permanente = 15 lbf/pi ²
Limite de flèche :	L/240 sous la charge totale
Revêtement :	Panneaux de copeaux orientés (OSB) 23/32 po, cloué et collé

Portées maximales de plancher

Limite de flèche de L/480 sous la surcharge

Hauteur	Série	Solive seule				Blocage à mi-portée			
		Espacement centre/centre				Espacement centre/centre			
		12"	16"	19,2"	24"	12"	16"	19,2"	24"
9-1/2"	NI-20	15'-9"	14'-10"	14'-4"	13'-5"	16'-7"	15'-4"	14'-6"	13'-5"
	NI-40x	16'-10"	15'-10"	15'-3"	14'-8"	17'-7"	16'-8"	16'-1"	15'-1"
	NI-60	16'-11"	16'-0"	15'-5"	14'-9"	17'-9"	16'-10"	16'-3"	15'-4"
	NI-80	18'-0"	16'-11"	16'-3"	15'-7"	19'-0"	17'-8"	17'-1"	16'-5"
11-7/8"	NI-20	17'-8"	16'-8"	16'-1"	15'-6"	18'-11"	17'-8"	17'-1"	16'-2"
	NI-40x	19'-1"	17'-9"	17'-1"	16'-5"	20'-5"	19'-0"	18'-1"	17'-5"
	NI-60	19'-4"	17'-11"	17'-3"	16'-7"	20'-8"	19'-2"	18'-4"	17'-7"
	NI-80	20'-9"	19'-2"	18'-3"	17'-5"	22'-1"	20'-6"	19'-7"	18'-7"
	NI-90	21'-2"	19'-7"	18'-8"	17'-9"	22'-7"	20'-11"	19'-11"	18'-11"
14"	NI-40x	21'-2"	19'-7"	18'-8"	17'-9"	22'-9"	21'-2"	20'-2"	19'-2"
	NI-60	21'-6"	19'-11"	19'-0"	18'-0"	23'-1"	21'-6"	20'-6"	19'-6"
	NI-80	23'-1"	21'-4"	20'-3"	19'-3"	24'-8"	22'-11"	21'-10"	20'-9"
	NI-90	23'-6"	21'-9"	20'-8"	19'-7"	25'-2"	23'-4"	22'-3"	21'-1"
16"	NI-60	23'-5"	21'-8"	20'-8"	19'-7"	25'-4"	23'-6"	22'-5"	21'-4"
	NI-80	25'-1"	23'-2"	22'-1"	20'-11"	27'-0"	25'-1"	23'-11"	22'-8"
	NI-90	25'-7"	23'-7"	22'-6"	21'-3"	27'-6"	25'-6"	24'-4"	23'-0"

Limite de flèche de L/360 sous la surcharge

Hauteur	Série	Solive seule				Blocage à mi-portée			
		Espacement centre/centre				Espacement centre/centre			
		12"	16"	19,2"	24"	12"	16"	19,2"	24"
9-1/2"	NI-20	15'-9"	14'-10"	14'-4"	13'-5"	16'-7"	15'-5"	14'-6"	13'-5"
	NI-40x	16'-10"	15'-10"	15'-3"	14'-8"	17'-7"	16'-8"	16'-1"	15'-3"
	NI-60	16'-11"	16'-0"	15'-5"	14'-9"	17'-9"	16'-10"	16'-3"	15'-7"
	NI-80	18'-0"	16'-11"	16'-3"	15'-7"	19'-0"	17'-8"	17'-1"	16'-5"
11-7/8"	NI-20	17'-8"	16'-8"	16'-1"	15'-6"	18'-11"	17'-8"	17'-1"	16'-2"
	NI-40x	19'-1"	17'-9"	17'-1"	16'-5"	20'-5"	19'-0"	18'-1"	17'-5"
	NI-60	19'-4"	17'-11"	17'-3"	16'-7"	20'-8"	19'-2"	18'-4"	17'-7"
	NI-80	20'-9"	19'-2"	18'-3"	17'-5"	22'-1"	20'-6"	19'-7"	18'-7"
	NI-90	21'-2"	19'-7"	18'-8"	17'-9"	22'-7"	20'-11"	19'-11"	18'-11"
14"	NI-40x	21'-2"	19'-7"	18'-8"	17'-9"	22'-9"	21'-2"	20'-2"	19'-2"
	NI-60	21'-6"	19'-11"	19'-0"	18'-0"	23'-1"	21'-6"	20'-6"	19'-6"
	NI-80	23'-1"	21'-4"	20'-3"	19'-3"	24'-8"	22'-11"	21'-10"	20'-9"
	NI-90	23'-6"	21'-9"	20'-8"	19'-7"	25'-2"	23'-4"	22'-3"	21'-1"
16"	NI-60	23'-5"	21'-8"	20'-8"	19'-7"	25'-4"	23'-6"	22'-5"	21'-4"
	NI-80	25'-1"	23'-2"	22'-1"	20'-11"	27'-0"	25'-1"	23'-11"	22'-8"
	NI-90	25'-7"	23'-7"	22'-6"	21'-3"	27'-6"	25'-6"	24'-4"	23'-0"

Notes :

1. Les portées libres indiquées sur la norme CSA O86-14 et le CNB 2015 et s'appliquent à la construction de planchers résidentiels respectant les critères de conception ci-dessus.
2. Pour les portées multiples, les portées extérieures doivent être supérieures à 40% de la portée adjacente.
3. La longueur d'appui minimale est de 1-3/4 pouce pour les appuis d'extrémités et de 3-1/2 pouces pour les appuis intermédiaires.
4. Les raidisseurs d'appui ne sont pas requis lorsque les solives sont utilisées conformément à ce tableau, sauf si requis pour les étriers.

Portées maximales de plancher – S3.2, blocage à mi-portée

Critères de conception

Portées :	Portées multiples
Charges :	Surcharge = 40 lbf/pi ² et charge permanente = 15 lbf/pi ²
Limite de flèche :	L/240 sous la charge totale
Revêtement :	Panneaux de copeaux orientés (OSB) 23/32 po, cloué et collé

Portées maximales de plancher

Limite de flèche de L/480 sous la surcharge

Hauteur	Série	Solive seule				Blocage à mi-portée			
		Espacement centre/centre				Espacement centre/centre			
		12"	16"	19,2"	24"	12"	16"	19,2"	24"
9-1/2"	NI-20	16'-11"	16'-0"	15'-5"	14'-7"	17'-9"	16'-9"	15'-9"	14'-7"
	NI-40x	18'-2"	17'-1"	16'-5"	15'-5"	19'-2"	17'-10"	17'-3"	15'-5"
	NI-60	18'-5"	17'-3"	16'-7"	15'-11"	19'-5"	18'-1"	17'-5"	16'-8"
	NI-80	19'-10"	18'-4"	17'-7"	16'-10"	20'-10"	19'-4"	18'-6"	17'-8"
11-7/8"	NI-20	19'-5"	18'-0"	17'-4"	16'-7"	20'-8"	19'-3"	18'-5"	16'-7"
	NI-40x	21'-0"	19'-6"	18'-7"	17'-7"	22'-4"	20'-9"	19'-9"	17'-7"
	NI-60	21'-4"	19'-9"	18'-10"	17'-11"	22'-8"	21'-1"	20'-1"	19'-2"
	NI-80	22'-11"	21'-2"	20'-2"	19'-1"	24'-3"	22'-6"	21'-6"	20'-5"
	NI-90	23'-5"	21'-7"	20'-7"	19'-6"	24'-9"	23'-0"	21'-11"	20'-9"
14"	NI-40x	23'-4"	21'-7"	20'-7"	19'-4"	24'-11"	23'-2"	21'-8"	19'-4"
	NI-60	23'-8"	21'-11"	20'-11"	19'-10"	25'-4"	23'-7"	22'-6"	21'-4"
	NI-80	25'-5"	23'-6"	22'-5"	21'-3"	27'-1"	25'-2"	24'-0"	22'-9"
	NI-90	26'-0"	24'-0"	22'-10"	21'-7"	27'-8"	25'-8"	24'-5"	23'-2"
16"	NI-60	25'-10"	23'-11"	22'-10"	21'-7"	27'-9"	25'-10"	24'-7"	23'-4"
	NI-80	27'-9"	25'-7"	24'-5"	23'-1"	29'-8"	27'-7"	26'-3"	24'-11"
	NI-90	28'-3"	26'-1"	24'-10"	23'-6"	30'-3"	28'-1"	26'-9"	25'-4"

Limite de flèche de L/360 sous la surcharge

Hauteur	Série	Solive seule				Blocage à mi-portée			
		Espacement centre/centre				Espacement centre/centre			
		12"	16"	19,2"	24"	12"	16"	19,2"	24"
9-1/2"	NI-20	16'-11"	16'-0"	15'-5"	14'-7"	17'-9"	16'-10"	15'-9"	14'-7"
	NI-40x	18'-2"	17'-1"	16'-5"	15'-5"	19'-2"	17'-10"	17'-3"	15'-5"
	NI-60	18'-5"	17'-3"	16'-7"	15'-11"	19'-5"	18'-1"	17'-5"	16'-9"
	NI-80	19'-10"	18'-4"	17'-7"	16'-10"	20'-10"	19'-4"	18'-6"	17'-8"
11-7/8"	NI-20	19'-5"	18'-0"	17'-4"	16'-7"	20'-8"	19'-3"	18'-5"	16'-7"
	NI-40x	21'-0"	19'-6"	18'-7"	17'-7"	22'-4"	20'-9"	19'-9"	17'-7"
	NI-60	21'-4"	19'-9"	18'-10"	17'-11"	22'-8"	21'-1"	20'-1"	19'-2"
	NI-80	22'-11"	21'-2"	20'-2"	19'-1"	24'-3"	22'-6"	21'-6"	20'-5"
	NI-90	23'-5"	21'-7"	20'-7"	19'-6"	24'-9"	23'-0"	21'-11"	20'-9"
14"	NI-40x	23'-4"	21'-7"	20'-7"	19'-4"	24'-11"	23'-2"	21'-8"	19'-4"
	NI-60	23'-8"	21'-11"	20'-11"	19'-10"	25'-4"	23'-7"	22'-6"	21'-4"
	NI-80	25'-5"	23'-6"	22'-5"	21'-3"	27'-1"	25'-2"	24'-0"	22'-9"
	NI-90	26'-0"	24'-0"	22'-10"	21'-7"	27'-8"	25'-8"	24'-5"	23'-2"
16"	NI-60	25'-10"	23'-11"	22'-10"	21'-7"	27'-9"	25'-10"	24'-7"	23'-4"
	NI-80	27'-9"	25'-7"	24'-5"	23'-1"	29'-8"	27'-7"	26'-3"	24'-11"
	NI-90	28'-3"	26'-1"	24'-10"	23'-6"	30'-3"	28'-1"	26'-9"	25'-4"

Notes :

1. Les portées libres indiquées sont basées sur la norme CSA O86-14 et le CNB 2015 et s'appliquent à la construction de planchers résidentiels respectant les critères de conception ci-dessus.
2. Pour les portées multiples, les portées extérieures doivent être supérieures à 40% de la portée adjacente.
3. La longueur d'appui minimale est de 1-3/4 pouce pour les appuis d'extrémités et de 3-1/2 pouces pour les appuis intermédiaires.
4. Les raidisseurs d'appui ne sont pas requis lorsque les solives sont utilisées conformément à ce tableau, sauf si requis pour les étriers.

Portées maximales de plancher – S4.1, blocage à mi-portée

Critères de conception

Portées :	Portée simple
Charges :	Surcharge = 40 lbf/pi ² et charge permanente = 15 lbf/pi ²
Limite de flèche :	L/240 sous la charge totale
Revêtement :	Panneaux de copeaux orientés (OSB) 3/4 po, cloué et collé

Portées maximales de plancher

Limite de flèche de L/480 sous la surcharge

Hauteur	Série	Solive seule				Blocage à mi-portée			
		Espacement centre/centre				Espacement centre/centre			
		12"	16"	19,2"	24"	12"	16"	19,2"	24"
9-1/2"	NI-20	15'-11"	15'-0"	14'-6"	13'-5"	16'-8"	15'-5"	14'-6"	13'-5"
	NI-40x	17'-0"	16'-0"	15'-5"	14'-10"	17'-9"	16'-10"	16'-3"	15'-2"
	NI-60	17'-2"	16'-2"	15'-7"	14'-11"	17'-11"	16'-11"	16'-4"	15'-5"
	NI-80	18'-3"	17'-1"	16'-5"	15'-9"	19'-3"	17'-10"	17'-3"	16'-6"
11-7/8"	NI-20	17'-11"	16'-11"	16'-3"	15'-8"	19'-1"	17'-10"	17'-3"	16'-2"
	NI-40x	19'-4"	17'-11"	17'-3"	16'-7"	20'-7"	19'-2"	18'-4"	17'-6"
	NI-60	19'-7"	18'-2"	17'-6"	16'-9"	20'-11"	19'-5"	18'-7"	17'-8"
	NI-80	21'-1"	19'-6"	18'-6"	17'-7"	22'-4"	20'-9"	19'-9"	18'-9"
	NI-90	21'-6"	19'-10"	18'-11"	17'-11"	22'-10"	21'-2"	20'-2"	19'-1"
14"	NI-40x	21'-5"	19'-11"	18'-11"	18'-0"	23'-0"	21'-5"	20'-5"	19'-4"
	NI-60	21'-10"	20'-2"	19'-3"	18'-3"	23'-4"	21'-9"	20'-9"	19'-8"
	NI-80	23'-5"	21'-7"	20'-7"	19'-5"	25'-0"	23'-2"	22'-1"	20'-11"
	NI-90	23'-10"	22'-1"	21'-0"	19'-10"	25'-5"	23'-7"	22'-6"	21'-4"
16"	NI-60	23'-9"	22'-0"	21'-0"	19'-10"	25'-7"	23'-9"	22'-8"	21'-6"
	NI-80	25'-6"	23'-7"	22'-5"	21'-2"	27'-4"	25'-4"	24'-2"	22'-10"
	NI-90	26'-0"	24'-0"	22'-10"	21'-6"	27'-10"	25'-10"	24'-7"	23'-3"

Limite de flèche de L/360 sous la surcharge

Hauteur	Série	Solive seule				Blocage à mi-portée			
		Espacement centre/centre				Espacement centre/centre			
		12"	16"	19,2"	24"	12"	16"	19,2"	24"
9-1/2"	NI-20	15'-11"	15'-0"	14'-6"	13'-5"	16'-8"	15'-5"	14'-6"	13'-5"
	NI-40x	17'-0"	16'-0"	15'-5"	14'-10"	17'-9"	16'-10"	16'-3"	15'-3"
	NI-60	17'-2"	16'-2"	15'-7"	14'-11"	17'-11"	16'-11"	16'-4"	15'-7"
	NI-80	18'-3"	17'-1"	16'-5"	15'-9"	19'-3"	17'-10"	17'-3"	16'-6"
11-7/8"	NI-20	17'-11"	16'-11"	16'-3"	15'-8"	19'-1"	17'-10"	17'-3"	16'-2"
	NI-40x	19'-4"	17'-11"	17'-3"	16'-7"	20'-7"	19'-2"	18'-4"	17'-6"
	NI-60	19'-7"	18'-2"	17'-6"	16'-9"	20'-11"	19'-5"	18'-7"	17'-8"
	NI-80	21'-1"	19'-6"	18'-6"	17'-7"	22'-4"	20'-9"	19'-9"	18'-9"
	NI-90	21'-6"	19'-10"	18'-11"	17'-11"	22'-10"	21'-2"	20'-2"	19'-1"
14"	NI-40x	21'-5"	19'-11"	18'-11"	18'-0"	23'-0"	21'-5"	20'-5"	19'-4"
	NI-60	21'-10"	20'-2"	19'-3"	18'-3"	23'-4"	21'-9"	20'-9"	19'-8"
	NI-80	23'-5"	21'-7"	20'-7"	19'-5"	25'-0"	23'-2"	22'-1"	20'-11"
	NI-90	23'-10"	22'-1"	21'-0"	19'-10"	25'-5"	23'-7"	22'-6"	21'-4"
16"	NI-60	23'-9"	22'-0"	21'-0"	19'-10"	25'-7"	23'-9"	22'-8"	21'-6"
	NI-80	25'-6"	23'-7"	22'-5"	21'-2"	27'-4"	25'-4"	24'-2"	22'-10"
	NI-90	26'-0"	24'-0"	22'-10"	21'-6"	27'-10"	25'-10"	24'-7"	23'-3"

Notes :

1. Les portées libres indiquées sont basées sur la norme CSA O86-14 et le CNB 2015 et s'appliquent à la construction de planchers résidentiels respectant les critères de conception ci-dessus.
2. Pour les portées multiples, les portées extérieures doivent être supérieures à 40% de la portée adjacente.
3. La longueur d'appui minimale est de 1-3/4 pouce pour les appuis d'extrémités et de 3-1/2 pouces pour les appuis intermédiaires.
4. Les raidisseurs d'appui ne sont pas requis lorsque les solives sont utilisées conformément à ce tableau, sauf si requis pour les étriers.

Portées maximales de plancher – S4.2, blocage à mi-portée

Critères de conception

Portées :	Portées multiples
Charges :	Surcharge = 40 lbf/pi ² et charge permanente = 15 lbf/pi ²
Limite de flèche :	L/240 sous la charge totale
Revêtement :	Panneaux de copeaux orientés (OSB) 3/4 po, cloué et collé

Portées maximales de plancher

Limite de flèche de L/480 sous la surcharge

Hauteur	Série	Solive seule				Blocage à mi-portée			
		Espacement centre/centre				Espacement centre/centre			
		12"	16"	19,2"	24"	12"	16"	19,2"	24"
9-1/2"	NI-20	17'-2"	16'-2"	15'-8"	14'-7"	17'-11"	16'-9"	15'-9"	14'-7"
	NI-40x	18'-5"	17'-3"	16'-8"	15'-5"	19'-5"	18'-1"	17'-3"	15'-5"
	NI-60	18'-8"	17'-5"	16'-10"	16'-1"	19'-8"	18'-4"	17'-7"	16'-9"
	NI-80	20'-1"	18'-7"	17'-9"	17'-0"	21'-1"	19'-7"	18'-8"	17'-9"
11-7/8"	NI-20	19'-8"	18'-3"	17'-7"	16'-7"	20'-11"	19'-6"	18'-7"	16'-7"
	NI-40x	21'-4"	19'-9"	18'-10"	17'-7"	22'-7"	21'-0"	19'-9"	17'-7"
	NI-60	21'-8"	20'-1"	19'-1"	18'-1"	22'-11"	21'-4"	20'-4"	19'-4"
	NI-80	23'-3"	21'-6"	20'-5"	19'-4"	24'-6"	22'-9"	21'-9"	20'-7"
	NI-90	23'-9"	21'-11"	20'-10"	19'-9"	25'-1"	23'-3"	22'-2"	21'-0"
14"	NI-40x	23'-8"	21'-11"	20'-11"	19'-4"	25'-2"	23'-5"	21'-8"	19'-4"
	NI-60	24'-1"	22'-3"	21'-3"	20'-1"	25'-7"	23'-10"	22'-9"	21'-7"
	NI-80	25'-10"	23'-10"	22'-9"	21'-6"	27'-5"	25'-5"	24'-3"	23'-0"
	NI-90	26'-4"	24'-4"	23'-2"	21'-11"	27'-11"	25'-11"	24'-9"	23'-5"
16"	NI-60	26'-3"	24'-3"	23'-2"	21'-11"	28'-1"	26'-1"	24'-11"	23'-7"
	NI-80	28'-2"	26'-0"	24'-9"	23'-5"	30'-0"	27'-10"	26'-7"	25'-1"
	NI-90	28'-8"	26'-6"	25'-2"	23'-10"	30'-7"	28'-4"	27'-0"	25'-7"

Limite de flèche de L/360 sous la surcharge

Hauteur	Série	Solive seule				Blocage à mi-portée			
		Espacement centre/centre				Espacement centre/centre			
		12"	16"	19,2"	24"	12"	16"	19,2"	24"
9-1/2"	NI-20	17'-2"	16'-2"	15'-8"	14'-7"	17'-11"	16'-10"	15'-9"	14'-7"
	NI-40x	18'-5"	17'-3"	16'-8"	15'-5"	19'-5"	18'-1"	17'-3"	15'-5"
	NI-60	18'-8"	17'-5"	16'-10"	16'-1"	19'-8"	18'-4"	17'-7"	16'-11"
	NI-80	20'-1"	18'-7"	17'-9"	17'-0"	21'-1"	19'-7"	18'-8"	17'-9"
11-7/8"	NI-20	19'-8"	18'-3"	17'-7"	16'-7"	20'-11"	19'-6"	18'-7"	16'-7"
	NI-40x	21'-4"	19'-9"	18'-10"	17'-7"	22'-7"	21'-0"	19'-9"	17'-7"
	NI-60	21'-8"	20'-1"	19'-1"	18'-1"	22'-11"	21'-4"	20'-4"	19'-4"
	NI-80	23'-3"	21'-6"	20'-5"	19'-4"	24'-6"	22'-9"	21'-9"	20'-7"
	NI-90	23'-9"	21'-11"	20'-10"	19'-9"	25'-1"	23'-3"	22'-2"	21'-0"
14"	NI-40x	23'-8"	21'-11"	20'-11"	19'-4"	25'-2"	23'-5"	21'-8"	19'-4"
	NI-60	24'-1"	22'-3"	21'-3"	20'-1"	25'-7"	23'-10"	22'-9"	21'-7"
	NI-80	25'-10"	23'-10"	22'-9"	21'-6"	27'-5"	25'-5"	24'-3"	23'-0"
	NI-90	26'-4"	24'-4"	23'-2"	21'-11"	27'-11"	25'-11"	24'-9"	23'-5"
16"	NI-60	26'-3"	24'-3"	23'-2"	21'-11"	28'-1"	26'-1"	24'-11"	23'-7"
	NI-80	28'-2"	26'-0"	24'-9"	23'-5"	30'-0"	27'-10"	26'-7"	25'-1"
	NI-90	28'-8"	26'-6"	25'-2"	23'-10"	30'-7"	28'-4"	27'-0"	25'-7"

Notes :

1. Les portées libres indiquées sur la norme CSA O86-14 et le CNB 2015 et s'appliquent à la construction de planchers résidentiels respectant les critères de conception ci-dessus.
2. Pour les portées multiples, les portées extérieures doivent être supérieures à 40% de la portée adjacente.
3. La longueur d'appui minimale est de 1-3/4 pouce pour les appuis d'extrémités et de 3-1/2 pouces pour les appuis intermédiaires.
4. Les raidisseurs d'appui ne sont pas requis lorsque les solives sont utilisées conformément à ce tableau, sauf si requis pour les étriers.

Portées maximales de plancher – S5.1, blocage à mi-portée

Critères de conception

Portées :	Portée simple
Charges :	Surcharge = 40 lbf/pi ² et charge permanente = 15 lbf/pi ²
Limite de flèche :	L/240 sous la charge totale
Revêtement :	Panneaux de copeaux orientés (OSB) 7/8 po, cloué et collé

Portées maximales de plancher

Limite de flèche de L/480 sous la surcharge

Hauteur	Série	Solive seule				Blocage à mi-portée			
		Espacement centre/centre				Espacement centre/centre			
		12"	16"	19,2"	24"	12"	16"	19,2"	24"
9-1/2"	NI-20	16'-8"	15'-5"	14'-6"	13'-5"	17'-0"	15'-5"	14'-6"	13'-5"
	NI-40x	17'-9"	16'-9"	16'-2"	15'-3"	18'-6"	17'-4"	16'-5"	15'-3"
	NI-60	17'-11"	16'-11"	16'-3"	15'-6"	18'-9"	17'-7"	16'-8"	15'-6"
	NI-80	19'-3"	17'-10"	17'-2"	16'-5"	20'-1"	18'-8"	17'-10"	17'-0"
11-7/8"	NI-20	18'-11"	17'-8"	17'-0"	16'-2"	19'-11"	18'-7"	17'-6"	16'-2"
	NI-40x	20'-5"	19'-0"	18'-1"	17'-3"	21'-6"	20'-0"	19'-1"	17'-8"
	NI-60	20'-8"	19'-3"	18'-4"	17'-5"	21'-9"	20'-4"	19'-4"	18'-4"
	NI-80	22'-2"	20'-7"	19'-7"	18'-5"	23'-3"	21'-8"	20'-8"	19'-6"
	NI-90	22'-8"	21'-0"	19'-11"	18'-9"	23'-9"	22'-1"	21'-1"	19'-10"
14"	NI-40x	22'-7"	21'-0"	20'-0"	18'-10"	23'-11"	22'-4"	21'-3"	19'-5"
	NI-60	23'-0"	21'-4"	20'-4"	19'-2"	24'-3"	22'-8"	21'-7"	20'-5"
	NI-80	24'-8"	22'-10"	21'-8"	20'-5"	26'-0"	24'-2"	23'-0"	21'-9"
	NI-90	25'-2"	23'-3"	22'-1"	20'-10"	26'-6"	24'-7"	23'-5"	22'-1"
16"	NI-60	25'-1"	23'-3"	22'-1"	20'-10"	26'-7"	24'-9"	23'-8"	22'-4"
	NI-80	26'-10"	24'-10"	23'-7"	22'-3"	28'-5"	26'-5"	25'-2"	23'-9"
	NI-90	27'-4"	25'-4"	24'-1"	22'-7"	28'-11"	26'-11"	25'-7"	24'-2"

Limite de flèche de L/360 sous la surcharge

Hauteur	Série	Solive seule				Blocage à mi-portée			
		Espacement centre/centre				Espacement centre/centre			
		12"	16"	19,2"	24"	12"	16"	19,2"	24"
9-1/2"	NI-20	16'-8"	15'-5"	14'-6"	13'-5"	17'-1"	15'-5"	14'-6"	13'-5"
	NI-40x	17'-9"	16'-9"	16'-2"	15'-3"	18'-6"	17'-5"	16'-7"	15'-3"
	NI-60	17'-11"	16'-11"	16'-3"	15'-7"	18'-9"	17'-7"	16'-10"	15'-7"
	NI-80	19'-3"	17'-10"	17'-2"	16'-5"	20'-1"	18'-8"	17'-10"	17'-1"
11-7/8"	NI-20	18'-11"	17'-8"	17'-0"	16'-2"	19'-11"	18'-7"	17'-6"	16'-2"
	NI-40x	20'-5"	19'-0"	18'-1"	17'-3"	21'-6"	20'-0"	19'-1"	17'-8"
	NI-60	20'-8"	19'-3"	18'-4"	17'-5"	21'-9"	20'-4"	19'-4"	18'-4"
	NI-80	22'-2"	20'-7"	19'-7"	18'-5"	23'-3"	21'-8"	20'-8"	19'-6"
	NI-90	22'-8"	21'-0"	19'-11"	18'-9"	23'-9"	22'-1"	21'-1"	19'-10"
14"	NI-40x	22'-7"	21'-0"	20'-0"	18'-10"	23'-11"	22'-4"	21'-3"	19'-5"
	NI-60	23'-0"	21'-4"	20'-4"	19'-2"	24'-3"	22'-8"	21'-7"	20'-5"
	NI-80	24'-8"	22'-10"	21'-8"	20'-5"	26'-0"	24'-2"	23'-0"	21'-9"
	NI-90	25'-2"	23'-3"	22'-1"	20'-10"	26'-6"	24'-7"	23'-5"	22'-1"
16"	NI-60	25'-1"	23'-3"	22'-1"	20'-10"	26'-7"	24'-9"	23'-8"	22'-4"
	NI-80	26'-10"	24'-10"	23'-7"	22'-3"	28'-5"	26'-5"	25'-2"	23'-9"
	NI-90	27'-4"	25'-4"	24'-1"	22'-7"	28'-11"	26'-11"	25'-7"	24'-2"

Notes :

1. Les portées libres indiquées sont basées sur la norme CSA O86-14 et le CNB 2015 et s'appliquent à la construction de planchers résidentiels respectant les critères de conception ci-dessus.
2. Pour les portées multiples, les portées extérieures doivent être supérieures à 40% de la portée adjacente.
3. La longueur d'appui minimale est de 1-3/4 pouce pour les appuis d'extrémités et de 3-1/2 pouces pour les appuis intermédiaires.
4. Les raidisseurs d'appui ne sont pas requis lorsque les solives sont utilisées conformément à ce tableau, sauf si requis pour les étriers.

Portées maximales de plancher – S5.2, blocage à mi-portée

Critères de conception

Portées :	Portées multiples
Charges :	Surcharge = 40 lbf/pi ² et charge permanente = 15 lbf/pi ²
Limite de flèche :	L/240 sous la charge totale
Revêtement :	Panneaux de copeaux orientés (OSB) 7/8 po, cloué et collé

Portées maximales de plancher

Limite de flèche de L/480 sous la surcharge

Hauteur	Série	Solive seule				Blocage à mi-portée			
		Espacement centre/centre				Espacement centre/centre			
		12"	16"	19,2"	24"	12"	16"	19,2"	24"
9-1/2"	NI-20	17'-11"	16'-10"	15'-9"	14'-7"	18'-6"	16'-10"	15'-9"	14'-7"
	NI-40x	19'-6"	18'-1"	17'-3"	15'-5"	20'-3"	18'-11"	17'-3"	15'-5"
	NI-60	19'-9"	18'-4"	17'-7"	16'-9"	20'-6"	19'-2"	18'-1"	16'-10"
	NI-80	21'-3"	19'-8"	18'-9"	17'-8"	22'-0"	20'-6"	19'-7"	18'-6"
11-7/8"	NI-20	20'-9"	19'-4"	18'-5"	16'-7"	21'-10"	20'-3"	18'-7"	16'-7"
	NI-40x	22'-6"	20'-11"	19'-9"	17'-7"	23'-7"	21'-7"	19'-9"	17'-7"
	NI-60	22'-10"	21'-2"	20'-2"	19'-0"	23'-10"	22'-3"	21'-3"	20'-1"
	NI-80	24'-6"	22'-8"	21'-7"	20'-4"	25'-7"	23'-10"	22'-8"	21'-5"
	NI-90	25'-0"	23'-2"	22'-0"	20'-9"	26'-1"	24'-3"	23'-2"	21'-10"
14"	NI-40x	24'-11"	23'-2"	21'-8"	19'-4"	26'-3"	23'-9"	21'-8"	19'-4"
	NI-60	25'-4"	23'-6"	22'-5"	21'-1"	26'-8"	24'-10"	23'-9"	22'-2"
	NI-80	27'-2"	25'-2"	24'-0"	22'-7"	28'-6"	26'-7"	25'-4"	23'-10"
	NI-90	27'-9"	25'-8"	24'-5"	23'-0"	29'-1"	27'-1"	25'-9"	24'-4"
16"	NI-60	27'-7"	25'-8"	24'-5"	23'-0"	29'-2"	27'-2"	25'-11"	23'-11"
	NI-80	29'-7"	27'-5"	26'-1"	24'-7"	31'-2"	29'-0"	27'-8"	26'-1"
	NI-90	30'-2"	27'-11"	26'-7"	25'-0"	31'-9"	29'-7"	28'-2"	26'-6"

Limite de flèche de L/360 sous la surcharge

Hauteur	Série	Solive seule				Blocage à mi-portée			
		Espacement centre/centre				Espacement centre/centre			
		12"	16"	19,2"	24"	12"	16"	19,2"	24"
9-1/2"	NI-20	17'-11"	16'-10"	15'-9"	14'-7"	18'-7"	16'-10"	15'-9"	14'-7"
	NI-40x	19'-6"	18'-1"	17'-3"	15'-5"	20'-3"	18'-11"	17'-3"	15'-5"
	NI-60	19'-9"	18'-4"	17'-7"	16'-9"	20'-6"	19'-2"	18'-3"	16'-11"
	NI-80	21'-3"	19'-8"	18'-9"	17'-8"	22'-0"	20'-6"	19'-7"	18'-6"
11-7/8"	NI-20	20'-9"	19'-4"	18'-5"	16'-7"	21'-10"	20'-4"	18'-7"	16'-7"
	NI-40x	22'-6"	20'-11"	19'-9"	17'-7"	23'-7"	21'-7"	19'-9"	17'-7"
	NI-60	22'-10"	21'-2"	20'-2"	19'-0"	23'-10"	22'-3"	21'-3"	20'-1"
	NI-80	24'-6"	22'-8"	21'-7"	20'-4"	25'-7"	23'-10"	22'-8"	21'-5"
	NI-90	25'-0"	23'-2"	22'-0"	20'-9"	26'-1"	24'-3"	23'-2"	21'-10"
14"	NI-40x	24'-11"	23'-2"	21'-8"	19'-4"	26'-3"	23'-9"	21'-8"	19'-4"
	NI-60	25'-4"	23'-6"	22'-5"	21'-1"	26'-8"	24'-10"	23'-9"	22'-2"
	NI-80	27'-2"	25'-2"	24'-0"	22'-7"	28'-6"	26'-7"	25'-4"	23'-10"
	NI-90	27'-9"	25'-8"	24'-5"	23'-0"	29'-1"	27'-1"	25'-9"	24'-4"
16"	NI-60	27'-7"	25'-8"	24'-5"	23'-0"	29'-2"	27'-2"	25'-11"	23'-11"
	NI-80	29'-7"	27'-5"	26'-1"	24'-7"	31'-2"	29'-0"	27'-8"	26'-1"
	NI-90	30'-2"	27'-11"	26'-7"	25'-0"	31'-9"	29'-7"	28'-2"	26'-6"

Notes :

1. Les portées libres indiquées sont basées sur la norme CSA O86-14 et le CNB 2015 et s'appliquent à la construction de planchers résidentiels respectant les critères de conception ci-dessus.
2. Pour les portées multiples, les portées extérieures doivent être supérieures à 40% de la portée adjacente.
3. La longueur d'appui minimale est de 1-3/4 pouce pour les appuis d'extrémités et de 3-1/2 pouces pour les appuis intermédiaires.
4. Les raidisseurs d'appui ne sont pas requis lorsque les solives sont utilisées conformément à ce tableau, sauf si requis pour les étriers.

Portées maximales de plancher – S6.1, blocage à mi-portée

Critères de conception

Portées :	Portée simple
Charges :	Surcharge = 40 lbf/pi ² et charge permanente = 15 lbf/pi ²
Limite de flèche :	L/240 sous la charge totale
Revêtement :	Contreplaqué de résineux canadiens 5/8 po, cloué et collé

Portées maximales de plancher

Limite de flèche de L/480 sous la surcharge

Hauteur	Série	Solive seule				Blocage à mi-portée			
		Espacement centre/centre				Espacement centre/centre			
		12"	16"	19,2"	24"	12"	16"	19,2"	24"
9-1/2"	NI-20	14'-11"	14'-1"	13'-7"	-	15'-10"	15'-0"	14'-3"	-
	NI-40x	15'-11"	15'-0"	14'-6"	-	16'-11"	16'-0"	15'-6"	-
	NI-60	16'-1"	15'-2"	14'-8"	-	17'-1"	16'-1"	15'-7"	-
	NI-80	17'-1"	16'-1"	15'-6"	-	18'-1"	17'-0"	16'-5"	-
11-7/8"	NI-20	16'-9"	15'-10"	15'-4"	-	17'-11"	17'-0"	16'-5"	-
	NI-40x	17'-10"	16'-10"	16'-3"	-	19'-5"	18'-0"	17'-5"	-
	NI-60	18'-1"	17'-0"	16'-5"	-	19'-8"	18'-3"	17'-7"	-
	NI-80	19'-6"	18'-0"	17'-4"	-	21'-1"	19'-6"	18'-8"	-
	NI-90	19'-11"	18'-4"	17'-8"	-	21'-6"	19'-11"	19'-0"	-
14"	NI-40x	19'-10"	18'-4"	17'-8"	-	21'-8"	20'-1"	19'-3"	-
	NI-60	20'-2"	18'-8"	17'-11"	-	22'-0"	20'-5"	19'-7"	-
	NI-80	21'-8"	20'-0"	19'-1"	-	23'-7"	21'-10"	20'-11"	-
	NI-90	22'-1"	20'-5"	19'-6"	-	24'-1"	22'-3"	21'-3"	-
16"	NI-60	22'-0"	20'-4"	19'-6"	-	24'-2"	22'-5"	21'-5"	-
	NI-80	23'-7"	21'-10"	20'-10"	-	25'-10"	23'-11"	22'-10"	-
	NI-90	24'-1"	22'-2"	21'-2"	-	26'-4"	24'-4"	23'-3"	-

Limite de flèche de L/360 sous la surcharge

Hauteur	Série	Solive seule				Blocage à mi-portée			
		Espacement centre/centre				Espacement centre/centre			
		12"	16"	19,2"	24"	12"	16"	19,2"	24"
9-1/2"	NI-20	14'-11"	14'-1"	13'-7"	-	15'-10"	15'-0"	14'-6"	-
	NI-40x	15'-11"	15'-0"	14'-6"	-	16'-11"	16'-0"	15'-6"	-
	NI-60	16'-1"	15'-2"	14'-8"	-	17'-1"	16'-1"	15'-7"	-
	NI-80	17'-1"	16'-1"	15'-6"	-	18'-1"	17'-0"	16'-5"	-
11-7/8"	NI-20	16'-9"	15'-10"	15'-4"	-	17'-11"	17'-0"	16'-5"	-
	NI-40x	17'-10"	16'-10"	16'-3"	-	19'-5"	18'-0"	17'-5"	-
	NI-60	18'-1"	17'-0"	16'-5"	-	19'-8"	18'-3"	17'-7"	-
	NI-80	19'-6"	18'-0"	17'-4"	-	21'-1"	19'-6"	18'-8"	-
	NI-90	19'-11"	18'-4"	17'-8"	-	21'-6"	19'-11"	19'-0"	-
14"	NI-40x	19'-10"	18'-4"	17'-8"	-	21'-8"	20'-1"	19'-3"	-
	NI-60	20'-2"	18'-8"	17'-11"	-	22'-0"	20'-5"	19'-7"	-
	NI-80	21'-8"	20'-0"	19'-1"	-	23'-7"	21'-10"	20'-11"	-
	NI-90	22'-1"	20'-5"	19'-6"	-	24'-1"	22'-3"	21'-3"	-
16"	NI-60	22'-0"	20'-4"	19'-6"	-	24'-2"	22'-5"	21'-5"	-
	NI-80	23'-7"	21'-10"	20'-10"	-	25'-10"	23'-11"	22'-10"	-
	NI-90	24'-1"	22'-2"	21'-2"	-	26'-4"	24'-4"	23'-3"	-

Notes :

1. Les portées libres indiquées sont basées sur la norme CSA O86-14 et le CNB 2015 et s'appliquent à la construction de planchers résidentiels respectant les critères de conception ci-dessus.
2. Pour les portées multiples, les portées extérieures doivent être supérieures à 40% de la portée adjacente.
3. La longueur d'appui minimale est de 1-3/4 pouce pour les appuis d'extrémités et de 3-1/2 pouces pour les appuis intermédiaires.
4. Les raidisseurs d'appui ne sont pas requis lorsque les solives sont utilisées conformément à ce tableau, sauf si requis pour les étriers.

Portées maximales de plancher – S6.2, blocage à mi-portée

Critères de conception

Portées :	Portées multiples
Charges :	Surcharge = 40 lbf/pi ² et charge permanente = 15 lbf/pi ²
Limite de flèche :	L/240 sous la charge totale
Revêtement :	Contreplaqué de résineux canadiens 5/8 po, cloué et collé

Portées maximales de plancher

Limite de flèche de L/480 sous la surcharge

Hauteur	Série	Solive seule				Blocage à mi-portée			
		Espacement centre/centre				Espacement centre/centre			
		12"	16"	19,2"	24"	12"	16"	19,2"	24"
9-1/2"	NI-20	16'-0"	15'-2"	14'-8"	-	17'-0"	16'-1"	15'-6"	-
	NI-40x	17'-2"	16'-2"	15'-8"	-	18'-2"	17'-2"	16'-7"	-
	NI-60	17'-4"	16'-4"	15'-10"	-	18'-5"	17'-4"	16'-9"	-
	NI-80	18'-7"	17'-4"	16'-9"	-	19'-10"	18'-5"	17'-8"	-
11-7/8"	NI-20	18'-1"	17'-1"	16'-6"	-	19'-7"	18'-4"	17'-8"	-
	NI-40x	19'-8"	18'-3"	17'-7"	-	21'-3"	19'-9"	18'-11"	-
	NI-60	20'-0"	18'-6"	17'-9"	-	21'-7"	20'-0"	19'-2"	-
	NI-80	21'-6"	19'-11"	19'-0"	-	23'-1"	21'-5"	20'-6"	-
14"	NI-90	22'-0"	20'-4"	19'-5"	-	23'-7"	21'-10"	20'-11"	-
	NI-40x	21'-10"	20'-3"	19'-5"	-	23'-9"	22'-1"	21'-2"	-
	NI-60	22'-3"	20'-7"	19'-9"	-	24'-2"	22'-5"	21'-6"	-
	NI-80	23'-11"	22'-1"	21'-1"	-	25'-11"	24'-0"	22'-11"	-
16"	NI-90	24'-5"	22'-7"	21'-6"	-	26'-5"	24'-5"	23'-4"	-
	NI-60	24'-3"	22'-6"	21'-6"	-	26'-6"	24'-7"	23'-6"	-
	NI-80	26'-1"	24'-1"	23'-0"	-	28'-4"	26'-3"	25'-1"	-
	NI-90	26'-7"	24'-7"	23'-5"	-	28'-11"	26'-9"	25'-7"	-

Limite de flèche de L/360 sous la surcharge

Hauteur	Série	Solive seule				Blocage à mi-portée			
		Espacement centre/centre				Espacement centre/centre			
		12"	16"	19,2"	24"	12"	16"	19,2"	24"
9-1/2"	NI-20	16'-0"	15'-2"	14'-8"	-	17'-0"	16'-1"	15'-7"	-
	NI-40x	17'-2"	16'-2"	15'-8"	-	18'-2"	17'-2"	16'-7"	-
	NI-60	17'-4"	16'-4"	15'-10"	-	18'-5"	17'-4"	16'-9"	-
	NI-80	18'-7"	17'-4"	16'-9"	-	19'-10"	18'-5"	17'-8"	-
11-7/8"	NI-20	18'-1"	17'-1"	16'-6"	-	19'-7"	18'-4"	17'-8"	-
	NI-40x	19'-8"	18'-3"	17'-7"	-	21'-3"	19'-9"	18'-11"	-
	NI-60	20'-0"	18'-6"	17'-9"	-	21'-7"	20'-0"	19'-2"	-
	NI-80	21'-6"	19'-11"	19'-0"	-	23'-1"	21'-5"	20'-6"	-
14"	NI-90	22'-0"	20'-4"	19'-5"	-	23'-7"	21'-10"	20'-11"	-
	NI-40x	21'-10"	20'-3"	19'-5"	-	23'-9"	22'-1"	21'-2"	-
	NI-60	22'-3"	20'-7"	19'-9"	-	24'-2"	22'-5"	21'-6"	-
	NI-80	23'-11"	22'-1"	21'-1"	-	25'-11"	24'-0"	22'-11"	-
16"	NI-90	24'-5"	22'-7"	21'-6"	-	26'-5"	24'-5"	23'-4"	-
	NI-60	24'-3"	22'-6"	21'-6"	-	26'-6"	24'-7"	23'-6"	-
	NI-80	26'-1"	24'-1"	23'-0"	-	28'-4"	26'-3"	25'-1"	-
	NI-90	26'-7"	24'-7"	23'-5"	-	28'-11"	26'-9"	25'-7"	-

Notes :

1. Les portées libres indiquées sont basées sur la norme CSA O86-14 et le CNB 2015 et s'appliquent à la construction de planchers résidentiels respectant les critères de conception ci-dessus.
2. Pour les portées multiples, les portées extérieures doivent être supérieures à 40% de la portée adjacente.
3. La longueur d'appui minimale est de 1-3/4 pouce pour les appuis d'extrémités et de 3-1/2 pouces pour les appuis intermédiaires.
4. Les raidisseurs d'appui ne sont pas requis lorsque les solives sont utilisées conformément à ce tableau, sauf si requis pour les étriers.

Portées maximales de plancher – S7.1, blocage à mi-portée

Critères de conception

Portées :	Portée simple
Charges :	Surcharge = 40 lbf/pi ² et charge permanente = 15 lbf/pi ²
Limite de flèche :	L/240 sous la charge totale
Revêtement :	Contreplaqué de résineux canadiens 3/4 po, cloué et collé

Portées maximales de plancher

Limite de flèche de L/480 sous la surcharge

Hauteur	Série	Solive seule				Blocage à mi-portée			
		Espacement centre/centre				Espacement centre/centre			
		12"	16"	19,2"	24"	12"	16"	19,2"	24"
9-1/2"	NI-20	15'-10"	15'-0"	14'-5"	13'-5"	16'-8"	15'-5"	14'-6"	13'-5"
	NI-40x	16'-11"	15'-11"	15'-4"	14'-9"	17'-8"	16'-9"	16'-2"	15'-2"
	NI-60	17'-1"	16'-1"	15'-6"	14'-10"	17'-10"	16'-11"	16'-4"	15'-5"
	NI-80	18'-1"	17'-0"	16'-4"	15'-8"	19'-2"	17'-10"	17'-2"	16'-6"
11-7/8"	NI-20	17'-10"	16'-10"	16'-2"	15'-7"	19'-0"	17'-9"	17'-2"	16'-2"
	NI-40x	19'-3"	17'-10"	17'-2"	16'-6"	20'-6"	19'-1"	18'-3"	17'-6"
	NI-60	19'-6"	18'-1"	17'-4"	16'-8"	20'-9"	19'-4"	18'-6"	17'-8"
	NI-80	20'-11"	19'-4"	18'-5"	17'-7"	22'-3"	20'-8"	19'-8"	18'-8"
	NI-90	21'-4"	19'-9"	18'-9"	17'-10"	22'-8"	21'-1"	20'-1"	19'-0"
14"	NI-40x	21'-4"	19'-9"	18'-10"	17'-11"	22'-10"	21'-3"	20'-4"	19'-4"
	NI-60	21'-8"	20'-1"	19'-2"	18'-2"	23'-3"	21'-7"	20'-7"	19'-7"
	NI-80	23'-3"	21'-6"	20'-5"	19'-4"	24'-10"	23'-1"	22'-0"	20'-10"
	NI-90	23'-9"	21'-11"	20'-10"	19'-8"	25'-4"	23'-6"	22'-5"	21'-2"
16"	NI-60	23'-7"	21'-10"	20'-10"	19'-9"	25'-5"	23'-8"	22'-7"	21'-5"
	NI-80	25'-4"	23'-5"	22'-3"	21'-1"	27'-2"	25'-3"	24'-1"	22'-9"
	NI-90	25'-10"	23'-10"	22'-8"	21'-5"	27'-8"	25'-8"	24'-6"	23'-2"

Limite de flèche de L/360 sous la surcharge

Hauteur	Série	Solive seule				Blocage à mi-portée			
		Espacement centre/centre				Espacement centre/centre			
		12"	16"	19,2"	24"	12"	16"	19,2"	24"
9-1/2"	NI-20	15'-10"	15'-0"	14'-5"	13'-5"	16'-8"	15'-5"	14'-6"	13'-5"
	NI-40x	16'-11"	15'-11"	15'-4"	14'-9"	17'-8"	16'-9"	16'-2"	15'-3"
	NI-60	17'-1"	16'-1"	15'-6"	14'-10"	17'-10"	16'-11"	16'-4"	15'-7"
	NI-80	18'-1"	17'-0"	16'-4"	15'-8"	19'-2"	17'-10"	17'-2"	16'-6"
11-7/8"	NI-20	17'-10"	16'-10"	16'-2"	15'-7"	19'-0"	17'-9"	17'-2"	16'-2"
	NI-40x	19'-3"	17'-10"	17'-2"	16'-6"	20'-6"	19'-1"	18'-3"	17'-6"
	NI-60	19'-6"	18'-1"	17'-4"	16'-8"	20'-9"	19'-4"	18'-6"	17'-8"
	NI-80	20'-11"	19'-4"	18'-5"	17'-7"	22'-3"	20'-8"	19'-8"	18'-8"
	NI-90	21'-4"	19'-9"	18'-9"	17'-10"	22'-8"	21'-1"	20'-1"	19'-0"
14"	NI-40x	21'-4"	19'-9"	18'-10"	17'-11"	22'-10"	21'-3"	20'-4"	19'-4"
	NI-60	21'-8"	20'-1"	19'-2"	18'-2"	23'-3"	21'-7"	20'-7"	19'-7"
	NI-80	23'-3"	21'-6"	20'-5"	19'-4"	24'-10"	23'-1"	22'-0"	20'-10"
	NI-90	23'-9"	21'-11"	20'-10"	19'-8"	25'-4"	23'-6"	22'-5"	21'-2"
16"	NI-60	23'-7"	21'-10"	20'-10"	19'-9"	25'-5"	23'-8"	22'-7"	21'-5"
	NI-80	25'-4"	23'-5"	22'-3"	21'-1"	27'-2"	25'-3"	24'-1"	22'-9"
	NI-90	25'-10"	23'-10"	22'-8"	21'-5"	27'-8"	25'-8"	24'-6"	23'-2"

Notes :

1. Les portées libres indiquées sont basées sur la norme CSA O86-14 et le CNB 2015 et s'appliquent à la construction de planchers résidentiels respectant les critères de conception ci-dessus.
2. Pour les portées multiples, les portées extérieures doivent être supérieures à 40% de la portée adjacente.
3. La longueur d'appui minimale est de 1-3/4 pouce pour les appuis d'extrémités et de 3-1/2 pouces pour les appuis intermédiaires.
4. Les raidisseurs d'appui ne sont pas requis lorsque les solives sont utilisées conformément à ce tableau, sauf si requis pour les étriers.

Portées maximales de plancher – S7.2, blocage à mi-portée

Critères de conception

Portées :	Portées multiples
Charges :	Surcharge = 40 lbf/pi ² et charge permanente = 15 lbf/pi ²
Limite de flèche :	L/240 sous la charge totale
Revêtement :	Contreplaqué de résineux canadiens 3/4 po, cloué et collé

Portées maximales de plancher

Limite de flèche de L/480 sous la surcharge

Hauteur	Série	Solive seule				Blocage à mi-portée			
		Espacement centre/centre				Espacement centre/centre			
		12"	16"	19,2"	24"	12"	16"	19,2"	24"
9-1/2"	NI-20	17'-1"	16'-1"	15'-7"	14'-7"	17'-10"	16'-9"	15'-9"	14'-7"
	NI-40x	18'-4"	17'-2"	16'-7"	15'-5"	19'-4"	18'-0"	17'-3"	15'-5"
	NI-60	18'-7"	17'-4"	16'-9"	16'-1"	19'-7"	18'-2"	17'-6"	16'-9"
	NI-80	20'-0"	18'-6"	17'-8"	16'-11"	21'-0"	19'-6"	18'-7"	17'-9"
11-7/8"	NI-20	19'-7"	18'-2"	17'-6"	16'-7"	20'-10"	19'-5"	18'-7"	16'-7"
	NI-40x	21'-2"	19'-8"	18'-9"	17'-7"	22'-6"	20'-11"	19'-9"	17'-7"
	NI-60	21'-6"	19'-11"	19'-0"	18'-0"	22'-10"	21'-2"	20'-3"	19'-3"
	NI-80	23'-1"	21'-4"	20'-4"	19'-3"	24'-5"	22'-8"	21'-7"	20'-6"
	NI-90	23'-7"	21'-9"	20'-9"	19'-8"	24'-11"	23'-1"	22'-1"	20'-11"
14"	NI-40x	23'-6"	21'-9"	20'-9"	19'-4"	25'-1"	23'-4"	21'-8"	19'-4"
	NI-60	23'-11"	22'-2"	21'-1"	20'-0"	25'-6"	23'-8"	22'-7"	21'-6"
	NI-80	25'-8"	23'-9"	22'-7"	21'-4"	27'-3"	25'-4"	24'-2"	22'-11"
	NI-90	26'-2"	24'-2"	23'-0"	21'-9"	27'-10"	25'-10"	24'-7"	23'-4"
16"	NI-60	26'-1"	24'-1"	23'-0"	21'-9"	27'-11"	25'-11"	24'-9"	23'-6"
	NI-80	27'-11"	25'-10"	24'-7"	23'-3"	29'-10"	27'-9"	26'-5"	25'-0"
	NI-90	28'-6"	26'-4"	25'-0"	23'-8"	30'-5"	28'-3"	26'-11"	25'-5"

Limite de flèche de L/360 sous la surcharge

Hauteur	Série	Solive seule				Blocage à mi-portée			
		Espacement centre/centre				Espacement centre/centre			
		12"	16"	19,2"	24"	12"	16"	19,2"	24"
9-1/2"	NI-20	17'-1"	16'-1"	15'-7"	14'-7"	17'-10"	16'-10"	15'-9"	14'-7"
	NI-40x	18'-4"	17'-2"	16'-7"	15'-5"	19'-4"	18'-0"	17'-3"	15'-5"
	NI-60	18'-7"	17'-4"	16'-9"	16'-1"	19'-7"	18'-2"	17'-6"	16'-10"
	NI-80	20'-0"	18'-6"	17'-8"	16'-11"	21'-0"	19'-6"	18'-7"	17'-9"
11-7/8"	NI-20	19'-7"	18'-2"	17'-6"	16'-7"	20'-10"	19'-5"	18'-7"	16'-7"
	NI-40x	21'-2"	19'-8"	18'-9"	17'-7"	22'-6"	20'-11"	19'-9"	17'-7"
	NI-60	21'-6"	19'-11"	19'-0"	18'-0"	22'-10"	21'-2"	20'-3"	19'-3"
	NI-80	23'-1"	21'-4"	20'-4"	19'-3"	24'-5"	22'-8"	21'-7"	20'-6"
	NI-90	23'-7"	21'-9"	20'-9"	19'-8"	24'-11"	23'-1"	22'-1"	20'-11"
14"	NI-40x	23'-6"	21'-9"	20'-9"	19'-4"	25'-1"	23'-4"	21'-8"	19'-4"
	NI-60	23'-11"	22'-2"	21'-1"	20'-0"	25'-6"	23'-8"	22'-7"	21'-6"
	NI-80	25'-8"	23'-9"	22'-7"	21'-4"	27'-3"	25'-4"	24'-2"	22'-11"
	NI-90	26'-2"	24'-2"	23'-0"	21'-9"	27'-10"	25'-10"	24'-7"	23'-4"
16"	NI-60	26'-1"	24'-1"	23'-0"	21'-9"	27'-11"	25'-11"	24'-9"	23'-6"
	NI-80	27'-11"	25'-10"	24'-7"	23'-3"	29'-10"	27'-9"	26'-5"	25'-0"
	NI-90	28'-6"	26'-4"	25'-0"	23'-8"	30'-5"	28'-3"	26'-11"	25'-5"

Notes :

1. Les portées libres indiquées sont basées sur la norme CSA O86-14 et le CNB 2015 et s'appliquent à la construction de planchers résidentiels respectant les critères de conception ci-dessus.
2. Pour les portées multiples, les portées extérieures doivent être supérieures à 40% de la portée adjacente.
3. La longueur d'appui minimale est de 1-3/4 pouce pour les appuis d'extrémités et de 3-1/2 pouces pour les appuis intermédiaires.
4. Les raidisseurs d'appui ne sont pas requis lorsque les solives sont utilisées conformément à ce tableau, sauf si requis pour les étriers.

Portées maximales de plancher – M1.1, blocage à mi-portée

Critères de conception

Portées :	Portée simple
Charges :	Surcharge = 40 lbf/pi ² et charge permanente = 20 lbf/pi ²
Limite de flèche :	L/240 sous la charge totale
Revêtement :	Panneaux de copeaux orientés (OSB) 19/32 po, cloué et collé

Portées maximales de plancher

Limite de flèche de L/480 sous la surcharge

Hauteur	Série	Solive seule				Blocage à mi-portée			
		Espacement centre/centre				Espacement centre/centre			
		12"	16"	19,2"	24"	12"	16"	19,2"	24"
9-1/2"	NI-20	14'-11"	14'-1"	13'-7"	-	15'-10"	15'-0"	14'-4"	-
	NI-40x	15'-11"	15'-0"	14'-6"	-	16'-11"	16'-0"	15'-6"	-
	NI-60	16'-1"	15'-2"	14'-8"	-	17'-1"	16'-1"	15'-7"	-
	NI-80	17'-0"	16'-0"	15'-6"	-	18'-0"	17'-0"	16'-5"	-
11-7/8"	NI-20	16'-9"	15'-10"	15'-4"	-	17'-11"	17'-0"	16'-6"	-
	NI-40x	17'-10"	16'-10"	16'-3"	-	19'-5"	18'-0"	17'-5"	-
	NI-60	18'-1"	17'-0"	16'-5"	-	19'-8"	18'-3"	17'-7"	-
	NI-80	19'-5"	17'-11"	17'-4"	-	21'-0"	19'-6"	18'-8"	-
	NI-90	19'-10"	18'-4"	17'-7"	-	21'-5"	19'-11"	19'-0"	-
14"	NI-40x	19'-9"	18'-4"	17'-8"	-	21'-8"	20'-1"	19'-4"	-
	NI-60	20'-1"	18'-7"	17'-10"	-	22'-0"	20'-5"	19'-7"	-
	NI-80	21'-7"	19'-11"	19'-1"	-	23'-6"	21'-10"	20'-10"	-
	NI-90	22'-0"	20'-4"	19'-5"	-	24'-0"	22'-3"	21'-3"	-
16"	NI-60	21'-11"	20'-4"	19'-5"	-	24'-2"	22'-5"	21'-6"	-
	NI-80	23'-6"	21'-9"	20'-9"	-	25'-10"	23'-11"	22'-10"	-
	NI-90	23'-11"	22'-1"	21'-2"	-	26'-3"	24'-4"	23'-3"	-

Limite de flèche de L/360 sous la surcharge

Hauteur	Série	Solive seule				Blocage à mi-portée			
		Espacement centre/centre				Espacement centre/centre			
		12"	16"	19,2"	24"	12"	16"	19,2"	24"
9-1/2"	NI-20	14'-11"	14'-1"	13'-7"	-	15'-10"	15'-0"	14'-6"	-
	NI-40x	15'-11"	15'-0"	14'-6"	-	16'-11"	16'-0"	15'-6"	-
	NI-60	16'-1"	15'-2"	14'-8"	-	17'-1"	16'-1"	15'-7"	-
	NI-80	17'-0"	16'-0"	15'-6"	-	18'-0"	17'-0"	16'-5"	-
11-7/8"	NI-20	16'-9"	15'-10"	15'-4"	-	17'-11"	17'-0"	16'-6"	-
	NI-40x	17'-10"	16'-10"	16'-3"	-	19'-5"	18'-0"	17'-5"	-
	NI-60	18'-1"	17'-0"	16'-5"	-	19'-8"	18'-3"	17'-7"	-
	NI-80	19'-5"	17'-11"	17'-4"	-	21'-0"	19'-6"	18'-8"	-
	NI-90	19'-10"	18'-4"	17'-7"	-	21'-5"	19'-11"	19'-0"	-
14"	NI-40x	19'-9"	18'-4"	17'-8"	-	21'-8"	20'-1"	19'-4"	-
	NI-60	20'-1"	18'-7"	17'-10"	-	22'-0"	20'-5"	19'-7"	-
	NI-80	21'-7"	19'-11"	19'-1"	-	23'-6"	21'-10"	20'-10"	-
	NI-90	22'-0"	20'-4"	19'-5"	-	24'-0"	22'-3"	21'-3"	-
16"	NI-60	21'-11"	20'-4"	19'-5"	-	24'-2"	22'-5"	21'-6"	-
	NI-80	23'-6"	21'-9"	20'-9"	-	25'-10"	23'-11"	22'-10"	-
	NI-90	23'-11"	22'-1"	21'-2"	-	26'-3"	24'-4"	23'-3"	-

Notes :

1. Les portées libres indiquées sont basées sur la norme CSA O86-14 et le CNB 2015 et s'appliquent à la construction de planchers résidentiels respectant les critères de conception ci-dessus.
2. Pour les portées multiples, les portées extérieures doivent être supérieures à 40% de la portée adjacente.
3. La longueur d'appui minimale est de 1-3/4 pouce pour les appuis d'extrémités et de 3-1/2 pouces pour les appuis intermédiaires.
4. Les raidisseurs d'appui ne sont pas requis lorsque les solives sont utilisées conformément à ce tableau, sauf si requis pour les étriers.

Portées maximales de plancher – M1.2, blocage à mi-portée

Critères de conception

Portées :	Portées multiples
Charges :	Surcharge = 40 lbf/pi ² et charge permanente = 20 lbf/pi ²
Limite de flèche :	L/240 sous la charge totale
Revêtement :	Panneaux de copeaux orientés (OSB) 19/32 po, cloué et collé

Portées maximales de plancher

Limite de flèche de L/480 sous la surcharge

Hauteur	Série	Solive seule				Blocage à mi-portée			
		Espacement centre/centre				Espacement centre/centre			
		12"	16"	19,2"	24"	12"	16"	19,2"	24"
9-1/2"	NI-20	16'-0"	15'-2"	14'-8"	-	17'-0"	16'-1"	15'-8"	-
	NI-40x	17'-2"	16'-2"	15'-8"	-	18'-2"	17'-2"	16'-7"	-
	NI-60	17'-4"	16'-4"	15'-10"	-	18'-5"	17'-4"	16'-9"	-
	NI-80	18'-6"	17'-4"	16'-9"	-	19'-9"	18'-4"	17'-8"	-
11-7/8"	NI-20	18'-1"	17'-1"	16'-6"	-	19'-8"	18'-4"	17'-8"	-
	NI-40x	19'-8"	18'-3"	17'-7"	-	21'-3"	19'-9"	18'-11"	-
	NI-60	19'-11"	18'-6"	17'-9"	-	21'-6"	20'-0"	19'-2"	-
	NI-80	21'-5"	19'-10"	19'-0"	-	23'-1"	21'-5"	20'-6"	-
14"	NI-90	21'-11"	20'-3"	19'-4"	-	23'-7"	21'-10"	20'-11"	-
	NI-40x	21'-9"	20'-3"	19'-4"	-	23'-9"	22'-1"	20'-10"	-
	NI-60	22'-2"	20'-7"	19'-8"	-	24'-1"	22'-5"	21'-6"	-
	NI-80	23'-10"	22'-0"	21'-1"	-	25'-10"	23'-11"	22'-11"	-
16"	NI-90	24'-4"	22'-6"	21'-6"	-	26'-4"	24'-5"	23'-4"	-
	NI-60	24'-2"	22'-5"	21'-5"	-	26'-5"	24'-7"	23'-6"	-
	NI-80	26'-0"	24'-0"	22'-11"	-	28'-4"	26'-3"	25'-1"	-
	NI-90	26'-6"	24'-5"	23'-4"	-	28'-10"	26'-8"	25'-6"	-

Limite de flèche de L/360 sous la surcharge

Hauteur	Série	Solive seule				Blocage à mi-portée			
		Espacement centre/centre				Espacement centre/centre			
		12"	16"	19,2"	24"	12"	16"	19,2"	24"
9-1/2"	NI-20	16'-0"	15'-2"	14'-8"	-	17'-0"	16'-1"	15'-8"	-
	NI-40x	17'-2"	16'-2"	15'-8"	-	18'-2"	17'-2"	16'-7"	-
	NI-60	17'-4"	16'-4"	15'-10"	-	18'-5"	17'-4"	16'-9"	-
	NI-80	18'-6"	17'-4"	16'-9"	-	19'-9"	18'-4"	17'-8"	-
11-7/8"	NI-20	18'-1"	17'-1"	16'-6"	-	19'-8"	18'-4"	17'-8"	-
	NI-40x	19'-8"	18'-3"	17'-7"	-	21'-3"	19'-9"	18'-11"	-
	NI-60	19'-11"	18'-6"	17'-9"	-	21'-6"	20'-0"	19'-2"	-
	NI-80	21'-5"	19'-10"	19'-0"	-	23'-1"	21'-5"	20'-6"	-
14"	NI-90	21'-11"	20'-3"	19'-4"	-	23'-7"	21'-10"	20'-11"	-
	NI-40x	21'-9"	20'-3"	19'-4"	-	23'-9"	22'-1"	20'-10"	-
	NI-60	22'-2"	20'-7"	19'-8"	-	24'-1"	22'-5"	21'-6"	-
	NI-80	23'-10"	22'-0"	21'-1"	-	25'-10"	23'-11"	22'-11"	-
16"	NI-90	24'-4"	22'-6"	21'-6"	-	26'-4"	24'-5"	23'-4"	-
	NI-60	24'-2"	22'-5"	21'-5"	-	26'-5"	24'-7"	23'-6"	-
	NI-80	26'-0"	24'-0"	22'-11"	-	28'-4"	26'-3"	25'-1"	-
	NI-90	26'-6"	24'-5"	23'-4"	-	28'-10"	26'-8"	25'-6"	-

Notes :

1. Les portées libres indiquées sur la norme CSA O86-14 et le CNB 2015 et s'appliquent à la construction de planchers résidentiels respectant les critères de conception ci-dessus.
2. Pour les portées multiples, les portées extérieures doivent être supérieures à 40% de la portée adjacente.
3. La longueur d'appui minimale est de 1-3/4 pouce pour les appuis d'extrémités et de 3-1/2 pouces pour les appuis intermédiaires.
4. Les raidisseurs d'appui ne sont pas requis lorsque les solives sont utilisées conformément à ce tableau, sauf si requis pour les étriers.

Portées maximales de plancher – M2.1, blocage à mi-portée

Critères de conception

Portées :	Portée simple
Charges :	Surcharge = 40 lbf/pi ² et charge permanente = 20 lbf/pi ²
Limite de flèche :	L/240 sous la charge totale
Revêtement :	Panneaux de copeaux orientés (OSB) 5/8 po, cloué et collé

Portées maximales de plancher

Limite de flèche de L/480 sous la surcharge

Hauteur	Série	Solive seule				Blocage à mi-portée			
		Espacement centre/centre				Espacement centre/centre			
		12"	16"	19,2"	24"	12"	16"	19,2"	24"
9-1/2"	NI-20	15'-1"	14'-3"	13'-10"	-	16'-1"	15'-2"	14'-5"	-
	NI-40x	16'-2"	15'-3"	14'-8"	-	17'-1"	16'-2"	15'-8"	-
	NI-60	16'-4"	15'-4"	14'-10"	-	17'-3"	16'-4"	15'-9"	-
	NI-80	17'-3"	16'-3"	15'-8"	-	18'-3"	17'-2"	16'-7"	-
11-7/8"	NI-20	17'-0"	16'-0"	15'-6"	-	18'-2"	17'-2"	16'-7"	-
	NI-40x	18'-2"	17'-1"	16'-6"	-	19'-8"	18'-3"	17'-7"	-
	NI-60	18'-5"	17'-3"	16'-8"	-	19'-11"	18'-6"	17'-9"	-
	NI-80	19'-9"	18'-3"	17'-7"	-	21'-4"	19'-9"	18'-11"	-
14"	NI-90	20'-2"	18'-8"	17'-10"	-	21'-9"	20'-2"	19'-3"	-
	NI-40x	20'-1"	18'-8"	17'-10"	-	21'-11"	20'-5"	19'-6"	-
	NI-60	20'-6"	18'-11"	18'-2"	-	22'-3"	20'-8"	19'-10"	-
	NI-80	21'-11"	20'-3"	19'-4"	-	23'-10"	22'-1"	21'-1"	-
16"	NI-90	22'-5"	20'-8"	19'-9"	-	24'-4"	22'-6"	21'-6"	-
	NI-60	22'-4"	20'-8"	19'-9"	-	24'-5"	22'-8"	21'-8"	-
	NI-80	23'-11"	22'-1"	21'-1"	-	26'-2"	24'-2"	23'-1"	-
	NI-90	24'-5"	22'-6"	21'-6"	-	26'-7"	24'-8"	23'-6"	-

Limite de flèche de L/360 sous la surcharge

Hauteur	Série	Solive seule				Blocage à mi-portée			
		Espacement centre/centre				Espacement centre/centre			
		12"	16"	19,2"	24"	12"	16"	19,2"	24"
9-1/2"	NI-20	15'-1"	14'-3"	13'-10"	-	16'-1"	15'-2"	14'-6"	-
	NI-40x	16'-2"	15'-3"	14'-8"	-	17'-1"	16'-2"	15'-8"	-
	NI-60	16'-4"	15'-4"	14'-10"	-	17'-3"	16'-4"	15'-9"	-
	NI-80	17'-3"	16'-3"	15'-8"	-	18'-3"	17'-2"	16'-7"	-
11-7/8"	NI-20	17'-0"	16'-0"	15'-6"	-	18'-2"	17'-2"	16'-7"	-
	NI-40x	18'-2"	17'-1"	16'-6"	-	19'-8"	18'-3"	17'-7"	-
	NI-60	18'-5"	17'-3"	16'-8"	-	19'-11"	18'-6"	17'-9"	-
	NI-80	19'-9"	18'-3"	17'-7"	-	21'-4"	19'-9"	18'-11"	-
14"	NI-90	20'-2"	18'-8"	17'-10"	-	21'-9"	20'-2"	19'-3"	-
	NI-40x	20'-1"	18'-8"	17'-10"	-	21'-11"	20'-5"	19'-6"	-
	NI-60	20'-6"	18'-11"	18'-2"	-	22'-3"	20'-8"	19'-10"	-
	NI-80	21'-11"	20'-3"	19'-4"	-	23'-10"	22'-1"	21'-1"	-
16"	NI-90	22'-5"	20'-8"	19'-9"	-	24'-4"	22'-6"	21'-6"	-
	NI-60	22'-4"	20'-8"	19'-9"	-	24'-5"	22'-8"	21'-8"	-
	NI-80	23'-11"	22'-1"	21'-1"	-	26'-2"	24'-2"	23'-1"	-
	NI-90	24'-5"	22'-6"	21'-6"	-	26'-7"	24'-8"	23'-6"	-

Notes :

1. Les portées libres indiquées sur la norme CSA O86-14 et le CNB 2015 et s'appliquent à la construction de planchers résidentiels respectant les critères de conception ci-dessus.
2. Pour les portées multiples, les portées extérieures doivent être supérieures à 40% de la portée adjacente.
3. La longueur d'appui minimale est de 1-3/4 pouce pour les appuis d'extrémités et de 3-1/2 pouces pour les appuis intermédiaires.
4. Les raidisseurs d'appui ne sont pas requis lorsque les solives sont utilisées conformément à ce tableau, sauf si requis pour les étriers.

Portées maximales de plancher – M2.2, blocage à mi-portée

Critères de conception

Portées :	Portées multiples
Charges :	Surcharge = 40 lbf/pi ² et charge permanente = 20 lbf/pi ²
Limite de flèche :	L/240 sous la charge totale
Revêtement :	Panneaux de copeaux orientés (OSB) 5/8 po, cloué et collé

Portées maximales de plancher

Limite de flèche de L/480 sous la surcharge

Hauteur	Série	Solive seule				Blocage à mi-portée			
		Espacement centre/centre				Espacement centre/centre			
		12"	16"	19,2"	24"	12"	16"	19,2"	24"
9-1/2"	NI-20	16'-3"	15'-4"	14'-10"	-	17'-2"	16'-4"	15'-8"	-
	NI-40x	17'-5"	16'-5"	15'-10"	-	18'-5"	17'-4"	16'-8"	-
	NI-60	17'-7"	16'-7"	16'-0"	-	18'-8"	17'-6"	16'-11"	-
	NI-80	18'-10"	17'-6"	16'-11"	-	20'-1"	18'-8"	17'-10"	-
11-7/8"	NI-20	18'-5"	17'-3"	16'-9"	-	19'-11"	18'-7"	17'-10"	-
	NI-40x	20'-0"	18'-7"	17'-9"	-	21'-6"	20'-0"	19'-0"	-
	NI-60	20'-3"	18'-10"	18'-0"	-	21'-10"	20'-3"	19'-5"	-
	NI-80	21'-10"	20'-2"	19'-3"	-	23'-5"	21'-8"	20'-9"	-
14"	NI-90	22'-3"	20'-7"	19'-8"	-	23'-10"	22'-1"	21'-2"	-
	NI-40x	22'-2"	20'-7"	19'-8"	-	24'-0"	22'-4"	20'-10"	-
	NI-60	22'-7"	20'-11"	20'-0"	-	24'-5"	22'-8"	21'-9"	-
	NI-80	24'-3"	22'-5"	21'-5"	-	26'-2"	24'-3"	23'-2"	-
16"	NI-90	24'-9"	22'-10"	21'-10"	-	26'-8"	24'-9"	23'-7"	-
	NI-60	24'-7"	22'-10"	21'-9"	-	26'-10"	24'-11"	23'-10"	-
	NI-80	26'-5"	24'-5"	23'-4"	-	28'-8"	26'-7"	25'-4"	-
	NI-90	26'-11"	24'-11"	23'-9"	-	29'-3"	27'-1"	25'-10"	-

Limite de flèche de L/360 sous la surcharge

Hauteur	Série	Solive seule				Blocage à mi-portée			
		Espacement centre/centre				Espacement centre/centre			
		12"	16"	19,2"	24"	12"	16"	19,2"	24"
9-1/2"	NI-20	16'-3"	15'-4"	14'-10"	-	17'-2"	16'-4"	15'-8"	-
	NI-40x	17'-5"	16'-5"	15'-10"	-	18'-5"	17'-4"	16'-8"	-
	NI-60	17'-7"	16'-7"	16'-0"	-	18'-8"	17'-6"	16'-11"	-
	NI-80	18'-10"	17'-6"	16'-11"	-	20'-1"	18'-8"	17'-10"	-
11-7/8"	NI-20	18'-5"	17'-3"	16'-9"	-	19'-11"	18'-7"	17'-10"	-
	NI-40x	20'-0"	18'-7"	17'-9"	-	21'-6"	20'-0"	19'-0"	-
	NI-60	20'-3"	18'-10"	18'-0"	-	21'-10"	20'-3"	19'-5"	-
	NI-80	21'-10"	20'-2"	19'-3"	-	23'-5"	21'-8"	20'-9"	-
14"	NI-90	22'-3"	20'-7"	19'-8"	-	23'-10"	22'-1"	21'-2"	-
	NI-40x	22'-2"	20'-7"	19'-8"	-	24'-0"	22'-4"	20'-10"	-
	NI-60	22'-7"	20'-11"	20'-0"	-	24'-5"	22'-8"	21'-9"	-
	NI-80	24'-3"	22'-5"	21'-5"	-	26'-2"	24'-3"	23'-2"	-
16"	NI-90	24'-9"	22'-10"	21'-10"	-	26'-8"	24'-9"	23'-7"	-
	NI-60	24'-7"	22'-10"	21'-9"	-	26'-10"	24'-11"	23'-10"	-
	NI-80	26'-5"	24'-5"	23'-4"	-	28'-8"	26'-7"	25'-4"	-
	NI-90	26'-11"	24'-11"	23'-9"	-	29'-3"	27'-1"	25'-10"	-

Notes :

1. Les portées libres indiquées sont basées sur la norme CSA O86-14 et le CNB 2015 et s'appliquent à la construction de planchers résidentiels respectant les critères de conception ci-dessus.
2. Pour les portées multiples, les portées extérieures doivent être supérieures à 40% de la portée adjacente.
3. La longueur d'appui minimale est de 1-3/4 pouce pour les appuis d'extrémités et de 3-1/2 pouces pour les appuis intermédiaires.
4. Les raidisseurs d'appui ne sont pas requis lorsque les solives sont utilisées conformément à ce tableau, sauf si requis pour les étriers.

Portées maximales de plancher – M3.1, blocage à mi-portée

Critères de conception

Portées :	Portée simple
Charges :	Surcharge = 40 lbf/pi ² et charge permanente = 20 lbf/pi ²
Limite de flèche :	L/240 sous la charge totale
Revêtement :	Panneaux de copeaux orientés (OSB) 23/32 po, cloué et collé

Portées maximales de plancher

Limite de flèche de L/480 sous la surcharge

Hauteur	Série	Solive seule				Blocage à mi-portée			
		Espacement centre/centre				Espacement centre/centre			
		12"	16"	19,2"	24"	12"	16"	19,2"	24"
9-1/2"	NI-20	15'-9"	14'-10"	14'-4"	13'-5"	16'-7"	15'-4"	14'-6"	13'-5"
	NI-40x	16'-10"	15'-10"	15'-3"	14'-8"	17'-7"	16'-8"	16'-1"	14'-11"
	NI-60	16'-11"	16'-0"	15'-5"	14'-9"	17'-9"	16'-10"	16'-3"	15'-4"
	NI-80	18'-0"	16'-11"	16'-3"	15'-7"	19'-0"	17'-8"	17'-1"	16'-5"
11-7/8"	NI-20	17'-8"	16'-8"	16'-1"	15'-6"	18'-11"	17'-8"	17'-1"	16'-1"
	NI-40x	19'-1"	17'-9"	17'-1"	16'-5"	20'-5"	19'-0"	18'-1"	17'-0"
	NI-60	19'-4"	17'-11"	17'-3"	16'-7"	20'-8"	19'-2"	18'-4"	17'-7"
	NI-80	20'-9"	19'-2"	18'-3"	17'-5"	22'-1"	20'-6"	19'-7"	18'-7"
	NI-90	21'-2"	19'-7"	18'-8"	17'-9"	22'-7"	20'-11"	19'-11"	18'-11"
14"	NI-40x	21'-2"	19'-7"	18'-8"	17'-9"	22'-9"	21'-2"	20'-2"	18'-8"
	NI-60	21'-6"	19'-11"	19'-0"	18'-0"	23'-1"	21'-6"	20'-6"	19'-6"
	NI-80	23'-1"	21'-4"	20'-3"	19'-3"	24'-8"	22'-11"	21'-10"	20'-9"
	NI-90	23'-6"	21'-9"	20'-8"	19'-7"	25'-2"	23'-4"	22'-3"	21'-1"
16"	NI-60	23'-5"	21'-8"	20'-8"	19'-7"	25'-4"	23'-6"	22'-5"	21'-4"
	NI-80	25'-1"	23'-2"	22'-1"	20'-11"	27'-0"	25'-1"	23'-11"	22'-8"
	NI-90	25'-7"	23'-7"	22'-6"	21'-3"	27'-6"	25'-6"	24'-4"	23'-0"

Limite de flèche de L/360 sous la surcharge

Hauteur	Série	Solive seule				Blocage à mi-portée			
		Espacement centre/centre				Espacement centre/centre			
		12"	16"	19,2"	24"	12"	16"	19,2"	24"
9-1/2"	NI-20	15'-9"	14'-10"	14'-4"	13'-5"	16'-7"	15'-5"	14'-6"	13'-5"
	NI-40x	16'-10"	15'-10"	15'-3"	14'-8"	17'-7"	16'-8"	16'-1"	14'-11"
	NI-60	16'-11"	16'-0"	15'-5"	14'-9"	17'-9"	16'-10"	16'-3"	15'-7"
	NI-80	18'-0"	16'-11"	16'-3"	15'-7"	19'-0"	17'-8"	17'-1"	16'-5"
11-7/8"	NI-20	17'-8"	16'-8"	16'-1"	15'-6"	18'-11"	17'-8"	17'-1"	16'-1"
	NI-40x	19'-1"	17'-9"	17'-1"	16'-5"	20'-5"	19'-0"	18'-1"	17'-0"
	NI-60	19'-4"	17'-11"	17'-3"	16'-7"	20'-8"	19'-2"	18'-4"	17'-7"
	NI-80	20'-9"	19'-2"	18'-3"	17'-5"	22'-1"	20'-6"	19'-7"	18'-7"
	NI-90	21'-2"	19'-7"	18'-8"	17'-9"	22'-7"	20'-11"	19'-11"	18'-11"
14"	NI-40x	21'-2"	19'-7"	18'-8"	17'-9"	22'-9"	21'-2"	20'-2"	18'-8"
	NI-60	21'-6"	19'-11"	19'-0"	18'-0"	23'-1"	21'-6"	20'-6"	19'-6"
	NI-80	23'-1"	21'-4"	20'-3"	19'-3"	24'-8"	22'-11"	21'-10"	20'-9"
	NI-90	23'-6"	21'-9"	20'-8"	19'-7"	25'-2"	23'-4"	22'-3"	21'-1"
16"	NI-60	23'-5"	21'-8"	20'-8"	19'-7"	25'-4"	23'-6"	22'-5"	21'-4"
	NI-80	25'-1"	23'-2"	22'-1"	20'-11"	27'-0"	25'-1"	23'-11"	22'-8"
	NI-90	25'-7"	23'-7"	22'-6"	21'-3"	27'-6"	25'-6"	24'-4"	23'-0"

Notes :

1. Les portées libres indiquées sur la norme CSA O86-14 et le CNB 2015 et s'appliquent à la construction de planchers résidentiels respectant les critères de conception ci-dessus.
2. Pour les portées multiples, les portées extérieures doivent être supérieures à 40% de la portée adjacente.
3. La longueur d'appui minimale est de 1-3/4 pouce pour les appuis d'extrémités et de 3-1/2 pouces pour les appuis intermédiaires.
4. Les raidisseurs d'appui ne sont pas requis lorsque les solives sont utilisées conformément à ce tableau, sauf si requis pour les étriers.

Portées maximales de plancher – M3.2, blocage à mi-portée

Critères de conception

Portées :	Portées multiples
Charges :	Surcharge = 40 lbf/pi ² et charge permanente = 20 lbf/pi ²
Limite de flèche :	L/240 sous la charge totale
Revêtement :	Panneaux de copeaux orientés (OSB) 23/32 po, cloué et collé

Portées maximales de plancher

Limite de flèche de L/480 sous la surcharge

Hauteur	Série	Solive seule				Blocage à mi-portée			
		Espacement centre/centre				Espacement centre/centre			
		12"	16"	19,2"	24"	12"	16"	19,2"	24"
9-1/2"	NI-20	16'-11"	16'-0"	15'-5"	14'-0"	17'-9"	16'-9"	15'-8"	14'-0"
	NI-40x	18'-2"	17'-1"	16'-5"	14'-10"	19'-2"	17'-10"	16'-8"	14'-10"
	NI-60	18'-5"	17'-3"	16'-7"	15'-11"	19'-5"	18'-1"	17'-5"	16'-8"
	NI-80	19'-10"	18'-4"	17'-7"	16'-10"	20'-10"	19'-4"	18'-6"	17'-7"
11-7/8"	NI-20	19'-5"	18'-0"	17'-4"	16'-0"	20'-8"	19'-3"	17'-11"	16'-0"
	NI-40x	21'-0"	19'-6"	18'-7"	16'-11"	22'-4"	20'-9"	19'-0"	16'-11"
	NI-60	21'-4"	19'-9"	18'-10"	17'-11"	22'-8"	21'-1"	20'-1"	19'-2"
	NI-80	22'-11"	21'-2"	20'-2"	19'-1"	24'-3"	22'-6"	21'-6"	20'-5"
	NI-90	23'-5"	21'-7"	20'-7"	19'-6"	24'-9"	23'-0"	21'-11"	20'-9"
14"	NI-40x	23'-4"	21'-7"	20'-7"	18'-7"	24'-11"	22'-10"	20'-10"	18'-7"
	NI-60	23'-8"	21'-11"	20'-11"	19'-10"	25'-4"	23'-7"	22'-6"	21'-4"
	NI-80	25'-5"	23'-6"	22'-5"	21'-3"	27'-1"	25'-2"	24'-0"	22'-9"
	NI-90	26'-0"	24'-0"	22'-10"	21'-7"	27'-8"	25'-8"	24'-5"	23'-2"
16"	NI-60	25'-10"	23'-11"	22'-10"	21'-7"	27'-9"	25'-10"	24'-7"	23'-0"
	NI-80	27'-9"	25'-7"	24'-5"	23'-1"	29'-8"	27'-7"	26'-3"	24'-11"
	NI-90	28'-3"	26'-1"	24'-10"	23'-6"	30'-3"	28'-1"	26'-9"	25'-4"

Limite de flèche de L/360 sous la surcharge

Hauteur	Série	Solive seule				Blocage à mi-portée			
		Espacement centre/centre				Espacement centre/centre			
		12"	16"	19,2"	24"	12"	16"	19,2"	24"
9-1/2"	NI-20	16'-11"	16'-0"	15'-5"	14'-0"	17'-9"	16'-10"	15'-8"	14'-0"
	NI-40x	18'-2"	17'-1"	16'-5"	14'-10"	19'-2"	17'-10"	16'-8"	14'-10"
	NI-60	18'-5"	17'-3"	16'-7"	15'-11"	19'-5"	18'-1"	17'-5"	16'-9"
	NI-80	19'-10"	18'-4"	17'-7"	16'-10"	20'-10"	19'-4"	18'-6"	17'-7"
11-7/8"	NI-20	19'-5"	18'-0"	17'-4"	16'-0"	20'-8"	19'-3"	17'-11"	16'-0"
	NI-40x	21'-0"	19'-6"	18'-7"	16'-11"	22'-4"	20'-9"	19'-0"	16'-11"
	NI-60	21'-4"	19'-9"	18'-10"	17'-11"	22'-8"	21'-1"	20'-1"	19'-2"
	NI-80	22'-11"	21'-2"	20'-2"	19'-1"	24'-3"	22'-6"	21'-6"	20'-5"
	NI-90	23'-5"	21'-7"	20'-7"	19'-6"	24'-9"	23'-0"	21'-11"	20'-9"
14"	NI-40x	23'-4"	21'-7"	20'-7"	18'-7"	24'-11"	22'-10"	20'-10"	18'-7"
	NI-60	23'-8"	21'-11"	20'-11"	19'-10"	25'-4"	23'-7"	22'-6"	21'-4"
	NI-80	25'-5"	23'-6"	22'-5"	21'-3"	27'-1"	25'-2"	24'-0"	22'-9"
	NI-90	26'-0"	24'-0"	22'-10"	21'-7"	27'-8"	25'-8"	24'-5"	23'-2"
16"	NI-60	25'-10"	23'-11"	22'-10"	21'-7"	27'-9"	25'-10"	24'-7"	23'-0"
	NI-80	27'-9"	25'-7"	24'-5"	23'-1"	29'-8"	27'-7"	26'-3"	24'-11"
	NI-90	28'-3"	26'-1"	24'-10"	23'-6"	30'-3"	28'-1"	26'-9"	25'-4"

Notes :

1. Les portées libres indiquées sont basées sur la norme CSA O86-14 et le CNB 2015 et s'appliquent à la construction de planchers résidentiels respectant les critères de conception ci-dessus.
2. Pour les portées multiples, les portées extérieures doivent être supérieures à 40% de la portée adjacente.
3. La longueur d'appui minimale est de 1-3/4 pouce pour les appuis d'extrémités et de 3-1/2 pouces pour les appuis intermédiaires.
4. Les raidisseurs d'appui ne sont pas requis lorsque les solives sont utilisées conformément à ce tableau, sauf si requis pour les étriers.

Portées maximales de plancher – M4.1, blocage à mi-portée

Critères de conception

Portées :	Portée simple
Charges :	Surcharge = 40 lbf/pi ² et charge permanente = 20 lbf/pi ²
Limite de flèche :	L/240 sous la charge totale
Revêtement :	Panneaux de copeaux orientés (OSB) 3/4 po, cloué et collé

Portées maximales de plancher

Limite de flèche de L/480 sous la surcharge

Hauteur	Série	Solive seule				Blocage à mi-portée			
		Espacement centre/centre				Espacement centre/centre			
		12"	16"	19,2"	24"	12"	16"	19,2"	24"
9-1/2"	NI-20	15'-11"	15'-0"	14'-6"	13'-5"	16'-8"	15'-5"	14'-6"	13'-5"
	NI-40x	17'-0"	16'-0"	15'-5"	14'-10"	17'-9"	16'-10"	16'-3"	14'-11"
	NI-60	17'-2"	16'-2"	15'-7"	14'-11"	17'-11"	16'-11"	16'-4"	15'-5"
	NI-80	18'-3"	17'-1"	16'-5"	15'-9"	19'-3"	17'-10"	17'-3"	16'-6"
11-7/8"	NI-20	17'-11"	16'-11"	16'-3"	15'-8"	19'-1"	17'-10"	17'-3"	16'-1"
	NI-40x	19'-4"	17'-11"	17'-3"	16'-7"	20'-7"	19'-2"	18'-4"	17'-0"
	NI-60	19'-7"	18'-2"	17'-6"	16'-9"	20'-11"	19'-5"	18'-7"	17'-8"
	NI-80	21'-1"	19'-6"	18'-6"	17'-7"	22'-4"	20'-9"	19'-9"	18'-9"
	NI-90	21'-6"	19'-10"	18'-11"	17'-11"	22'-10"	21'-2"	20'-2"	19'-1"
14"	NI-40x	21'-5"	19'-11"	18'-11"	18'-0"	23'-0"	21'-5"	20'-5"	18'-8"
	NI-60	21'-10"	20'-2"	19'-3"	18'-3"	23'-4"	21'-9"	20'-9"	19'-8"
	NI-80	23'-5"	21'-7"	20'-7"	19'-5"	25'-0"	23'-2"	22'-1"	20'-11"
	NI-90	23'-10"	22'-1"	21'-0"	19'-10"	25'-5"	23'-7"	22'-6"	21'-4"
16"	NI-60	23'-9"	22'-0"	21'-0"	19'-10"	25'-7"	23'-9"	22'-8"	21'-6"
	NI-80	25'-6"	23'-7"	22'-5"	21'-2"	27'-4"	25'-4"	24'-2"	22'-10"
	NI-90	26'-0"	24'-0"	22'-10"	21'-6"	27'-10"	25'-10"	24'-7"	23'-3"

Limite de flèche de L/360 sous la surcharge

Hauteur	Série	Solive seule				Blocage à mi-portée			
		Espacement centre/centre				Espacement centre/centre			
		12"	16"	19,2"	24"	12"	16"	19,2"	24"
9-1/2"	NI-20	15'-11"	15'-0"	14'-6"	13'-5"	16'-8"	15'-5"	14'-6"	13'-5"
	NI-40x	17'-0"	16'-0"	15'-5"	14'-10"	17'-9"	16'-10"	16'-3"	14'-11"
	NI-60	17'-2"	16'-2"	15'-7"	14'-11"	17'-11"	16'-11"	16'-4"	15'-7"
	NI-80	18'-3"	17'-1"	16'-5"	15'-9"	19'-3"	17'-10"	17'-3"	16'-6"
11-7/8"	NI-20	17'-11"	16'-11"	16'-3"	15'-8"	19'-1"	17'-10"	17'-3"	16'-1"
	NI-40x	19'-4"	17'-11"	17'-3"	16'-7"	20'-7"	19'-2"	18'-4"	17'-0"
	NI-60	19'-7"	18'-2"	17'-6"	16'-9"	20'-11"	19'-5"	18'-7"	17'-8"
	NI-80	21'-1"	19'-6"	18'-6"	17'-7"	22'-4"	20'-9"	19'-9"	18'-9"
	NI-90	21'-6"	19'-10"	18'-11"	17'-11"	22'-10"	21'-2"	20'-2"	19'-1"
14"	NI-40x	21'-5"	19'-11"	18'-11"	18'-0"	23'-0"	21'-5"	20'-5"	18'-8"
	NI-60	21'-10"	20'-2"	19'-3"	18'-3"	23'-4"	21'-9"	20'-9"	19'-8"
	NI-80	23'-5"	21'-7"	20'-7"	19'-5"	25'-0"	23'-2"	22'-1"	20'-11"
	NI-90	23'-10"	22'-1"	21'-0"	19'-10"	25'-5"	23'-7"	22'-6"	21'-4"
16"	NI-60	23'-9"	22'-0"	21'-0"	19'-10"	25'-7"	23'-9"	22'-8"	21'-6"
	NI-80	25'-6"	23'-7"	22'-5"	21'-2"	27'-4"	25'-4"	24'-2"	22'-10"
	NI-90	26'-0"	24'-0"	22'-10"	21'-6"	27'-10"	25'-10"	24'-7"	23'-3"

Notes :

1. Les portées libres indiquées sur la norme CSA O86-14 et le CNB 2015 et s'appliquent à la construction de planchers résidentiels respectant les critères de conception ci-dessus.
2. Pour les portées multiples, les portées extérieures doivent être supérieures à 40% de la portée adjacente.
3. La longueur d'appui minimale est de 1-3/4 pouce pour les appuis d'extrémités et de 3-1/2 pouces pour les appuis intermédiaires.
4. Les raidisseurs d'appui ne sont pas requis lorsque les solives sont utilisées conformément à ce tableau, sauf si requis pour les étriers.

Portées maximales de plancher – M4.2, blocage à mi-portée

Critères de conception

Portées :	Portées multiples
Charges :	Surcharge = 40 lbf/pi ² et charge permanente = 20 lbf/pi ²
Limite de flèche :	L/240 sous la charge totale
Revêtement :	Panneaux de copeaux orientés (OSB) 3/4 po, cloué et collé

Portées maximales de plancher

Limite de flèche de L/480 sous la surcharge

Hauteur	Série	Solive seule				Blocage à mi-portée			
		Espacement centre/centre				Espacement centre/centre			
		12"	16"	19,2"	24"	12"	16"	19,2"	24"
9-1/2"	NI-20	17'-2"	16'-2"	15'-8"	14'-0"	17'-11"	16'-9"	15'-8"	14'-0"
	NI-40x	18'-5"	17'-3"	16'-8"	14'-10"	19'-5"	18'-1"	16'-8"	14'-10"
	NI-60	18'-8"	17'-5"	16'-10"	16'-1"	19'-8"	18'-4"	17'-7"	16'-9"
	NI-80	20'-1"	18'-7"	17'-9"	17'-0"	21'-1"	19'-7"	18'-8"	17'-7"
11-7/8"	NI-20	19'-8"	18'-3"	17'-7"	16'-0"	20'-11"	19'-6"	17'-11"	16'-0"
	NI-40x	21'-4"	19'-9"	18'-10"	16'-11"	22'-7"	20'-10"	19'-0"	16'-11"
	NI-60	21'-8"	20'-1"	19'-1"	18'-1"	22'-11"	21'-4"	20'-4"	19'-4"
	NI-80	23'-3"	21'-6"	20'-5"	19'-4"	24'-6"	22'-9"	21'-9"	20'-7"
	NI-90	23'-9"	21'-11"	20'-10"	19'-9"	25'-1"	23'-3"	22'-2"	21'-0"
14"	NI-40x	23'-8"	21'-11"	20'-10"	18'-7"	25'-2"	22'-10"	20'-10"	18'-7"
	NI-60	24'-1"	22'-3"	21'-3"	20'-1"	25'-7"	23'-10"	22'-9"	21'-4"
	NI-80	25'-10"	23'-10"	22'-9"	21'-6"	27'-5"	25'-5"	24'-3"	23'-0"
	NI-90	26'-4"	24'-4"	23'-2"	21'-11"	27'-11"	25'-11"	24'-9"	23'-5"
16"	NI-60	26'-3"	24'-3"	23'-2"	21'-11"	28'-1"	26'-1"	24'-11"	23'-0"
	NI-80	28'-2"	26'-0"	24'-9"	23'-5"	30'-0"	27'-10"	26'-7"	25'-1"
	NI-90	28'-8"	26'-6"	25'-2"	23'-10"	30'-7"	28'-4"	27'-0"	25'-7"

Limite de flèche de L/360 sous la surcharge

Hauteur	Série	Solive seule				Blocage à mi-portée			
		Espacement centre/centre				Espacement centre/centre			
		12"	16"	19,2"	24"	12"	16"	19,2"	24"
9-1/2"	NI-20	17'-2"	16'-2"	15'-8"	14'-0"	17'-11"	16'-10"	15'-8"	14'-0"
	NI-40x	18'-5"	17'-3"	16'-8"	14'-10"	19'-5"	18'-1"	16'-8"	14'-10"
	NI-60	18'-8"	17'-5"	16'-10"	16'-1"	19'-8"	18'-4"	17'-7"	16'-11"
	NI-80	20'-1"	18'-7"	17'-9"	17'-0"	21'-1"	19'-7"	18'-8"	17'-7"
11-7/8"	NI-20	19'-8"	18'-3"	17'-7"	16'-0"	20'-11"	19'-6"	17'-11"	16'-0"
	NI-40x	21'-4"	19'-9"	18'-10"	16'-11"	22'-7"	20'-10"	19'-0"	16'-11"
	NI-60	21'-8"	20'-1"	19'-1"	18'-1"	22'-11"	21'-4"	20'-4"	19'-4"
	NI-80	23'-3"	21'-6"	20'-5"	19'-4"	24'-6"	22'-9"	21'-9"	20'-7"
	NI-90	23'-9"	21'-11"	20'-10"	19'-9"	25'-1"	23'-3"	22'-2"	21'-0"
14"	NI-40x	23'-8"	21'-11"	20'-10"	18'-7"	25'-2"	22'-10"	20'-10"	18'-7"
	NI-60	24'-1"	22'-3"	21'-3"	20'-1"	25'-7"	23'-10"	22'-9"	21'-4"
	NI-80	25'-10"	23'-10"	22'-9"	21'-6"	27'-5"	25'-5"	24'-3"	23'-0"
	NI-90	26'-4"	24'-4"	23'-2"	21'-11"	27'-11"	25'-11"	24'-9"	23'-5"
16"	NI-60	26'-3"	24'-3"	23'-2"	21'-11"	28'-1"	26'-1"	24'-11"	23'-0"
	NI-80	28'-2"	26'-0"	24'-9"	23'-5"	30'-0"	27'-10"	26'-7"	25'-1"
	NI-90	28'-8"	26'-6"	25'-2"	23'-10"	30'-7"	28'-4"	27'-0"	25'-7"

Notes :

1. Les portées libres indiquées sont basées sur la norme CSA O86-14 et le CNB 2015 et s'appliquent à la construction de planchers résidentiels respectant les critères de conception ci-dessus.
2. Pour les portées multiples, les portées extérieures doivent être supérieures à 40% de la portée adjacente.
3. La longueur d'appui minimale est de 1-3/4 pouce pour les appuis d'extrémités et de 3-1/2 pouces pour les appuis intermédiaires.
4. Les raidisseurs d'appui ne sont pas requis lorsque les solives sont utilisées conformément à ce tableau, sauf si requis pour les étriers.

Portées maximales de plancher – M5.1, blocage à mi-portée

Critères de conception

Portées :	Portée simple
Charges :	Surcharge = 40 lbf/pi ² et charge permanente = 20 lbf/pi ²
Limite de flèche :	L/240 sous la charge totale
Revêtement :	Panneaux de copeaux orientés (OSB) 7/8 po, cloué et collé

Portées maximales de plancher

Limite de flèche de L/480 sous la surcharge

Hauteur	Série	Solive seule				Blocage à mi-portée			
		Espacement centre/centre				Espacement centre/centre			
		12"	16"	19,2"	24"	12"	16"	19,2"	24"
9-1/2"	NI-20	16'-8"	15'-5"	14'-6"	13'-5"	17'-0"	15'-5"	14'-6"	13'-5"
	NI-40x	17'-9"	16'-9"	16'-2"	14'-11"	18'-6"	17'-4"	16'-5"	14'-11"
	NI-60	17'-11"	16'-11"	16'-3"	15'-6"	18'-9"	17'-7"	16'-8"	15'-6"
	NI-80	19'-3"	17'-10"	17'-2"	16'-5"	20'-1"	18'-8"	17'-10"	17'-0"
11-7/8"	NI-20	18'-11"	17'-8"	17'-0"	16'-1"	19'-11"	18'-7"	17'-6"	16'-1"
	NI-40x	20'-5"	19'-0"	18'-1"	17'-0"	21'-6"	20'-0"	19'-0"	17'-0"
	NI-60	20'-8"	19'-3"	18'-4"	17'-5"	21'-9"	20'-4"	19'-4"	18'-4"
	NI-80	22'-2"	20'-7"	19'-7"	18'-5"	23'-3"	21'-8"	20'-8"	19'-6"
	NI-90	22'-8"	21'-0"	19'-11"	18'-9"	23'-9"	22'-1"	21'-1"	19'-10"
14"	NI-40x	22'-7"	21'-0"	20'-0"	18'-8"	23'-11"	22'-4"	20'-11"	18'-8"
	NI-60	23'-0"	21'-4"	20'-4"	19'-2"	24'-3"	22'-8"	21'-7"	20'-5"
	NI-80	24'-8"	22'-10"	21'-8"	20'-5"	26'-0"	24'-2"	23'-0"	21'-9"
	NI-90	25'-2"	23'-3"	22'-1"	20'-10"	26'-6"	24'-7"	23'-5"	22'-1"
16"	NI-60	25'-1"	23'-3"	22'-1"	20'-10"	26'-7"	24'-9"	23'-8"	22'-4"
	NI-80	26'-10"	24'-10"	23'-7"	22'-3"	28'-5"	26'-5"	25'-2"	23'-9"
	NI-90	27'-4"	25'-4"	24'-1"	22'-7"	28'-11"	26'-11"	25'-7"	24'-2"

Limite de flèche de L/360 sous la surcharge

Hauteur	Série	Solive seule				Blocage à mi-portée			
		Espacement centre/centre				Espacement centre/centre			
		12"	16"	19,2"	24"	12"	16"	19,2"	24"
9-1/2"	NI-20	16'-8"	15'-5"	14'-6"	13'-5"	17'-1"	15'-5"	14'-6"	13'-5"
	NI-40x	17'-9"	16'-9"	16'-2"	14'-11"	18'-6"	17'-5"	16'-7"	14'-11"
	NI-60	17'-11"	16'-11"	16'-3"	15'-7"	18'-9"	17'-7"	16'-10"	15'-7"
	NI-80	19'-3"	17'-10"	17'-2"	16'-5"	20'-1"	18'-8"	17'-10"	17'-1"
11-7/8"	NI-20	18'-11"	17'-8"	17'-0"	16'-1"	19'-11"	18'-7"	17'-6"	16'-1"
	NI-40x	20'-5"	19'-0"	18'-1"	17'-0"	21'-6"	20'-0"	19'-0"	17'-0"
	NI-60	20'-8"	19'-3"	18'-4"	17'-5"	21'-9"	20'-4"	19'-4"	18'-4"
	NI-80	22'-2"	20'-7"	19'-7"	18'-5"	23'-3"	21'-8"	20'-8"	19'-6"
	NI-90	22'-8"	21'-0"	19'-11"	18'-9"	23'-9"	22'-1"	21'-1"	19'-10"
14"	NI-40x	22'-7"	21'-0"	20'-0"	18'-8"	23'-11"	22'-4"	20'-11"	18'-8"
	NI-60	23'-0"	21'-4"	20'-4"	19'-2"	24'-3"	22'-8"	21'-7"	20'-5"
	NI-80	24'-8"	22'-10"	21'-8"	20'-5"	26'-0"	24'-2"	23'-0"	21'-9"
	NI-90	25'-2"	23'-3"	22'-1"	20'-10"	26'-6"	24'-7"	23'-5"	22'-1"
16"	NI-60	25'-1"	23'-3"	22'-1"	20'-10"	26'-7"	24'-9"	23'-8"	22'-4"
	NI-80	26'-10"	24'-10"	23'-7"	22'-3"	28'-5"	26'-5"	25'-2"	23'-9"
	NI-90	27'-4"	25'-4"	24'-1"	22'-7"	28'-11"	26'-11"	25'-7"	24'-2"

Notes :

1. Les portées libres indiquées sont basées sur la norme CSA O86-14 et le CNB 2015 et s'appliquent à la construction de planchers résidentiels respectant les critères de conception ci-dessus.
2. Pour les portées multiples, les portées extérieures doivent être supérieures à 40% de la portée adjacente.
3. La longueur d'appui minimale est de 1-3/4 pouce pour les appuis d'extrémités et de 3-1/2 pouces pour les appuis intermédiaires.
4. Les raidisseurs d'appui ne sont pas requis lorsque les solives sont utilisées conformément à ce tableau, sauf si requis pour les étriers.

Portées maximales de plancher – M5.2, blocage à mi-portée

Critères de conception

Portées :	Portées multiples
Charges :	Surcharge = 40 lbf/pi ² et charge permanente = 20 lbf/pi ²
Limite de flèche :	L/240 sous la charge totale
Revêtement :	Panneaux de copeaux orientés (OSB) 7/8 po, cloué et collé

Portées maximales de plancher

Limite de flèche de L/480 sous la surcharge

Hauteur	Série	Solive seule				Blocage à mi-portée			
		Espacement centre/centre				Espacement centre/centre			
		12"	16"	19,2"	24"	12"	16"	19,2"	24"
9-1/2"	NI-20	17'-11"	16'-10"	15'-8"	14'-0"	18'-6"	16'-10"	15'-8"	14'-0"
	NI-40x	19'-6"	18'-1"	16'-8"	14'-10"	20'-3"	18'-3"	16'-8"	14'-10"
	NI-60	19'-9"	18'-4"	17'-7"	16'-9"	20'-6"	19'-2"	18'-1"	16'-10"
	NI-80	21'-3"	19'-8"	18'-9"	17'-7"	22'-0"	20'-6"	19'-7"	17'-7"
11-7/8"	NI-20	20'-9"	19'-4"	17'-11"	16'-0"	21'-10"	19'-8"	17'-11"	16'-0"
	NI-40x	22'-6"	20'-10"	19'-0"	16'-11"	23'-7"	20'-10"	19'-0"	16'-11"
	NI-60	22'-10"	21'-2"	20'-2"	19'-0"	23'-10"	22'-3"	21'-3"	19'-5"
	NI-80	24'-6"	22'-8"	21'-7"	20'-4"	25'-7"	23'-10"	22'-8"	21'-5"
	NI-90	25'-0"	23'-2"	22'-0"	20'-9"	26'-1"	24'-3"	23'-2"	21'-10"
14"	NI-40x	24'-11"	22'-10"	20'-10"	18'-7"	26'-3"	22'-10"	20'-10"	18'-7"
	NI-60	25'-4"	23'-6"	22'-5"	21'-1"	26'-8"	24'-10"	23'-9"	21'-4"
	NI-80	27'-2"	25'-2"	24'-0"	22'-7"	28'-6"	26'-7"	25'-4"	23'-10"
	NI-90	27'-9"	25'-8"	24'-5"	23'-0"	29'-1"	27'-1"	25'-9"	24'-4"
16"	NI-60	27'-7"	25'-8"	24'-5"	23'-0"	29'-2"	27'-2"	25'-9"	23'-0"
	NI-80	29'-7"	27'-5"	26'-1"	24'-7"	31'-2"	29'-0"	27'-8"	26'-1"
	NI-90	30'-2"	27'-11"	26'-7"	25'-0"	31'-9"	29'-7"	28'-2"	26'-6"

Limite de flèche de L/360 sous la surcharge

Hauteur	Série	Solive seule				Blocage à mi-portée			
		Espacement centre/centre				Espacement centre/centre			
		12"	16"	19,2"	24"	12"	16"	19,2"	24"
9-1/2"	NI-20	17'-11"	16'-10"	15'-8"	14'-0"	18'-7"	16'-10"	15'-8"	14'-0"
	NI-40x	19'-6"	18'-1"	16'-8"	14'-10"	20'-3"	18'-3"	16'-8"	14'-10"
	NI-60	19'-9"	18'-4"	17'-7"	16'-9"	20'-6"	19'-2"	18'-3"	16'-11"
	NI-80	21'-3"	19'-8"	18'-9"	17'-7"	22'-0"	20'-6"	19'-7"	17'-7"
11-7/8"	NI-20	20'-9"	19'-4"	17'-11"	16'-0"	21'-10"	19'-8"	17'-11"	16'-0"
	NI-40x	22'-6"	20'-10"	19'-0"	16'-11"	23'-7"	20'-10"	19'-0"	16'-11"
	NI-60	22'-10"	21'-2"	20'-2"	19'-0"	23'-10"	22'-3"	21'-3"	19'-5"
	NI-80	24'-6"	22'-8"	21'-7"	20'-4"	25'-7"	23'-10"	22'-8"	21'-5"
	NI-90	25'-0"	23'-2"	22'-0"	20'-9"	26'-1"	24'-3"	23'-2"	21'-10"
14"	NI-40x	24'-11"	22'-10"	20'-10"	18'-7"	26'-3"	22'-10"	20'-10"	18'-7"
	NI-60	25'-4"	23'-6"	22'-5"	21'-1"	26'-8"	24'-10"	23'-9"	21'-4"
	NI-80	27'-2"	25'-2"	24'-0"	22'-7"	28'-6"	26'-7"	25'-4"	23'-10"
	NI-90	27'-9"	25'-8"	24'-5"	23'-0"	29'-1"	27'-1"	25'-9"	24'-4"
16"	NI-60	27'-7"	25'-8"	24'-5"	23'-0"	29'-2"	27'-2"	25'-9"	23'-0"
	NI-80	29'-7"	27'-5"	26'-1"	24'-7"	31'-2"	29'-0"	27'-8"	26'-1"
	NI-90	30'-2"	27'-11"	26'-7"	25'-0"	31'-9"	29'-7"	28'-2"	26'-6"

Notes :

1. Les portées libres indiquées sont basées sur la norme CSA O86-14 et le CNB 2015 et s'appliquent à la construction de planchers résidentiels respectant les critères de conception ci-dessus.
2. Pour les portées multiples, les portées extérieures doivent être supérieures à 40% de la portée adjacente.
3. La longueur d'appui minimale est de 1-3/4 pouce pour les appuis d'extrémités et de 3-1/2 pouces pour les appuis intermédiaires.
4. Les raidisseurs d'appui ne sont pas requis lorsque les solives sont utilisées conformément à ce tableau, sauf si requis pour les étriers.

Portées maximales de plancher – M6.1, blocage à mi-portée

Critères de conception

Portées :	Portée simple
Charges :	Surcharge = 40 lbf/pi ² et charge permanente = 20 lbf/pi ²
Limite de flèche :	L/240 sous la charge totale
Revêtement :	Contreplaqué de résineux canadiens 5/8 po, cloué et collé

Portées maximales de plancher

Limite de flèche de L/480 sous la surcharge

Hauteur	Série	Solive seule				Blocage à mi-portée			
		Espacement centre/centre				Espacement centre/centre			
		12"	16"	19,2"	24"	12"	16"	19,2"	24"
9-1/2"	NI-20	14'-11"	14'-1"	13'-7"	-	15'-10"	15'-0"	14'-3"	-
	NI-40x	15'-11"	15'-0"	14'-6"	-	16'-11"	16'-0"	15'-6"	-
	NI-60	16'-1"	15'-2"	14'-8"	-	17'-1"	16'-1"	15'-7"	-
	NI-80	17'-1"	16'-1"	15'-6"	-	18'-1"	17'-0"	16'-5"	-
11-7/8"	NI-20	16'-9"	15'-10"	15'-4"	-	17'-11"	17'-0"	16'-5"	-
	NI-40x	17'-10"	16'-10"	16'-3"	-	19'-5"	18'-0"	17'-5"	-
	NI-60	18'-1"	17'-0"	16'-5"	-	19'-8"	18'-3"	17'-7"	-
	NI-80	19'-6"	18'-0"	17'-4"	-	21'-1"	19'-6"	18'-8"	-
	NI-90	19'-11"	18'-4"	17'-8"	-	21'-6"	19'-11"	19'-0"	-
14"	NI-40x	19'-10"	18'-4"	17'-8"	-	21'-8"	20'-1"	19'-3"	-
	NI-60	20'-2"	18'-8"	17'-11"	-	22'-0"	20'-5"	19'-7"	-
	NI-80	21'-8"	20'-0"	19'-1"	-	23'-7"	21'-10"	20'-11"	-
	NI-90	22'-1"	20'-5"	19'-6"	-	24'-1"	22'-3"	21'-3"	-
16"	NI-60	22'-0"	20'-4"	19'-6"	-	24'-2"	22'-5"	21'-5"	-
	NI-80	23'-7"	21'-10"	20'-10"	-	25'-10"	23'-11"	22'-10"	-
	NI-90	24'-1"	22'-2"	21'-2"	-	26'-4"	24'-4"	23'-3"	-

Limite de flèche de L/360 sous la surcharge

Hauteur	Série	Solive seule				Blocage à mi-portée			
		Espacement centre/centre				Espacement centre/centre			
		12"	16"	19,2"	24"	12"	16"	19,2"	24"
9-1/2"	NI-20	14'-11"	14'-1"	13'-7"	-	15'-10"	15'-0"	14'-6"	-
	NI-40x	15'-11"	15'-0"	14'-6"	-	16'-11"	16'-0"	15'-6"	-
	NI-60	16'-1"	15'-2"	14'-8"	-	17'-1"	16'-1"	15'-7"	-
	NI-80	17'-1"	16'-1"	15'-6"	-	18'-1"	17'-0"	16'-5"	-
11-7/8"	NI-20	16'-9"	15'-10"	15'-4"	-	17'-11"	17'-0"	16'-5"	-
	NI-40x	17'-10"	16'-10"	16'-3"	-	19'-5"	18'-0"	17'-5"	-
	NI-60	18'-1"	17'-0"	16'-5"	-	19'-8"	18'-3"	17'-7"	-
	NI-80	19'-6"	18'-0"	17'-4"	-	21'-1"	19'-6"	18'-8"	-
	NI-90	19'-11"	18'-4"	17'-8"	-	21'-6"	19'-11"	19'-0"	-
14"	NI-40x	19'-10"	18'-4"	17'-8"	-	21'-8"	20'-1"	19'-3"	-
	NI-60	20'-2"	18'-8"	17'-11"	-	22'-0"	20'-5"	19'-7"	-
	NI-80	21'-8"	20'-0"	19'-1"	-	23'-7"	21'-10"	20'-11"	-
	NI-90	22'-1"	20'-5"	19'-6"	-	24'-1"	22'-3"	21'-3"	-
16"	NI-60	22'-0"	20'-4"	19'-6"	-	24'-2"	22'-5"	21'-5"	-
	NI-80	23'-7"	21'-10"	20'-10"	-	25'-10"	23'-11"	22'-10"	-
	NI-90	24'-1"	22'-2"	21'-2"	-	26'-4"	24'-4"	23'-3"	-

Notes :

1. Les portées libres indiquées sont basées sur la norme CSA O86-14 et le CNB 2015 et s'appliquent à la construction de planchers résidentiels respectant les critères de conception ci-dessus.
2. Pour les portées multiples, les portées extérieures doivent être supérieures à 40% de la portée adjacente.
3. La longueur d'appui minimale est de 1-3/4 pouce pour les appuis d'extrémités et de 3-1/2 pouces pour les appuis intermédiaires.
4. Les raidisseurs d'appui ne sont pas requis lorsque les solives sont utilisées conformément à ce tableau, sauf si requis pour les étriers.

Portées maximales de plancher – M6.2, blocage à mi-portée

Critères de conception

Portées :	Portées multiples
Charges :	Surcharge = 40 lbf/pi ² et charge permanente = 20 lbf/pi ²
Limite de flèche :	L/240 sous la charge totale
Revêtement :	Contreplaqué de résineux canadiens 5/8 po, cloué et collé

Portées maximales de plancher

Limite de flèche de L/480 sous la surcharge

Hauteur	Série	Solive seule				Blocage à mi-portée			
		Espacement centre/centre				Espacement centre/centre			
		12"	16"	19,2"	24"	12"	16"	19,2"	24"
9-1/2"	NI-20	16'-0"	15'-2"	14'-8"	-	17'-0"	16'-1"	15'-6"	-
	NI-40x	17'-2"	16'-2"	15'-8"	-	18'-2"	17'-2"	16'-7"	-
	NI-60	17'-4"	16'-4"	15'-10"	-	18'-5"	17'-4"	16'-9"	-
	NI-80	18'-7"	17'-4"	16'-9"	-	19'-10"	18'-5"	17'-8"	-
11-7/8"	NI-20	18'-1"	17'-1"	16'-6"	-	19'-7"	18'-4"	17'-8"	-
	NI-40x	19'-8"	18'-3"	17'-7"	-	21'-3"	19'-9"	18'-11"	-
	NI-60	20'-0"	18'-6"	17'-9"	-	21'-7"	20'-0"	19'-2"	-
	NI-80	21'-6"	19'-11"	19'-0"	-	23'-1"	21'-5"	20'-6"	-
14"	NI-90	22'-0"	20'-4"	19'-5"	-	23'-7"	21'-10"	20'-11"	-
	NI-40x	21'-10"	20'-3"	19'-5"	-	23'-9"	22'-1"	20'-10"	-
	NI-60	22'-3"	20'-7"	19'-9"	-	24'-2"	22'-5"	21'-6"	-
	NI-80	23'-11"	22'-1"	21'-1"	-	25'-11"	24'-0"	22'-11"	-
16"	NI-90	24'-5"	22'-7"	21'-6"	-	26'-5"	24'-5"	23'-4"	-
	NI-60	24'-3"	22'-6"	21'-6"	-	26'-6"	24'-7"	23'-6"	-
	NI-80	26'-1"	24'-1"	23'-0"	-	28'-4"	26'-3"	25'-1"	-
	NI-90	26'-7"	24'-7"	23'-5"	-	28'-11"	26'-9"	25'-7"	-

Limite de flèche de L/360 sous la surcharge

Hauteur	Série	Solive seule				Blocage à mi-portée			
		Espacement centre/centre				Espacement centre/centre			
		12"	16"	19,2"	24"	12"	16"	19,2"	24"
9-1/2"	NI-20	16'-0"	15'-2"	14'-8"	-	17'-0"	16'-1"	15'-7"	-
	NI-40x	17'-2"	16'-2"	15'-8"	-	18'-2"	17'-2"	16'-7"	-
	NI-60	17'-4"	16'-4"	15'-10"	-	18'-5"	17'-4"	16'-9"	-
	NI-80	18'-7"	17'-4"	16'-9"	-	19'-10"	18'-5"	17'-8"	-
11-7/8"	NI-20	18'-1"	17'-1"	16'-6"	-	19'-7"	18'-4"	17'-8"	-
	NI-40x	19'-8"	18'-3"	17'-7"	-	21'-3"	19'-9"	18'-11"	-
	NI-60	20'-0"	18'-6"	17'-9"	-	21'-7"	20'-0"	19'-2"	-
	NI-80	21'-6"	19'-11"	19'-0"	-	23'-1"	21'-5"	20'-6"	-
14"	NI-90	22'-0"	20'-4"	19'-5"	-	23'-7"	21'-10"	20'-11"	-
	NI-40x	21'-10"	20'-3"	19'-5"	-	23'-9"	22'-1"	20'-10"	-
	NI-60	22'-3"	20'-7"	19'-9"	-	24'-2"	22'-5"	21'-6"	-
	NI-80	23'-11"	22'-1"	21'-1"	-	25'-11"	24'-0"	22'-11"	-
16"	NI-90	24'-5"	22'-7"	21'-6"	-	26'-5"	24'-5"	23'-4"	-
	NI-60	24'-3"	22'-6"	21'-6"	-	26'-6"	24'-7"	23'-6"	-
	NI-80	26'-1"	24'-1"	23'-0"	-	28'-4"	26'-3"	25'-1"	-
	NI-90	26'-7"	24'-7"	23'-5"	-	28'-11"	26'-9"	25'-7"	-

Notes :

1. Les portées libres indiquées sont basées sur la norme CSA O86-14 et le CNB 2015 et s'appliquent à la construction de planchers résidentiels respectant les critères de conception ci-dessus.
2. Pour les portées multiples, les portées extérieures doivent être supérieures à 40% de la portée adjacente.
3. La longueur d'appui minimale est de 1-3/4 pouce pour les appuis d'extrémités et de 3-1/2 pouces pour les appuis intermédiaires.
4. Les raidisseurs d'appui ne sont pas requis lorsque les solives sont utilisées conformément à ce tableau, sauf si requis pour les étriers.

Portées maximales de plancher – M7.1, blocage à mi-portée

Critères de conception

Portées :	Portée simple
Charges :	Surcharge = 40 lbf/pi ² et charge permanente = 20 lbf/pi ²
Limite de flèche :	L/240 sous la charge totale
Revêtement :	Contreplaqué de résineux canadiens 3/4 po, cloué et collé

Portées maximales de plancher

Limite de flèche de L/480 sous la surcharge

Hauteur	Série	Solive seule				Blocage à mi-portée			
		Espacement centre/centre				Espacement centre/centre			
		12"	16"	19,2"	24"	12"	16"	19,2"	24"
9-1/2"	NI-20	15'-10"	15'-0"	14'-5"	13'-5"	16'-8"	15'-5"	14'-6"	13'-5"
	NI-40x	16'-11"	15'-11"	15'-4"	14'-9"	17'-8"	16'-9"	16'-2"	14'-11"
	NI-60	17'-1"	16'-1"	15'-6"	14'-10"	17'-10"	16'-11"	16'-4"	15'-5"
	NI-80	18'-1"	17'-0"	16'-4"	15'-8"	19'-2"	17'-10"	17'-2"	16'-6"
11-7/8"	NI-20	17'-10"	16'-10"	16'-2"	15'-7"	19'-0"	17'-9"	17'-2"	16'-1"
	NI-40x	19'-3"	17'-10"	17'-2"	16'-6"	20'-6"	19'-1"	18'-3"	17'-0"
	NI-60	19'-6"	18'-1"	17'-4"	16'-8"	20'-9"	19'-4"	18'-6"	17'-8"
	NI-80	20'-11"	19'-4"	18'-5"	17'-7"	22'-3"	20'-8"	19'-8"	18'-8"
	NI-90	21'-4"	19'-9"	18'-9"	17'-10"	22'-8"	21'-1"	20'-1"	19'-0"
14"	NI-40x	21'-4"	19'-9"	18'-10"	17'-11"	22'-10"	21'-3"	20'-4"	18'-8"
	NI-60	21'-8"	20'-1"	19'-2"	18'-2"	23'-3"	21'-7"	20'-7"	19'-7"
	NI-80	23'-3"	21'-6"	20'-5"	19'-4"	24'-10"	23'-1"	22'-0"	20'-10"
	NI-90	23'-9"	21'-11"	20'-10"	19'-8"	25'-4"	23'-6"	22'-5"	21'-2"
16"	NI-60	23'-7"	21'-10"	20'-10"	19'-9"	25'-5"	23'-8"	22'-7"	21'-5"
	NI-80	25'-4"	23'-5"	22'-3"	21'-1"	27'-2"	25'-3"	24'-1"	22'-9"
	NI-90	25'-10"	23'-10"	22'-8"	21'-5"	27'-8"	25'-8"	24'-6"	23'-2"

Limite de flèche de L/360 sous la surcharge

Hauteur	Série	Solive seule				Blocage à mi-portée			
		Espacement centre/centre				Espacement centre/centre			
		12"	16"	19,2"	24"	12"	16"	19,2"	24"
9-1/2"	NI-20	15'-10"	15'-0"	14'-5"	13'-5"	16'-8"	15'-5"	14'-6"	13'-5"
	NI-40x	16'-11"	15'-11"	15'-4"	14'-9"	17'-8"	16'-9"	16'-2"	14'-11"
	NI-60	17'-1"	16'-1"	15'-6"	14'-10"	17'-10"	16'-11"	16'-4"	15'-7"
	NI-80	18'-1"	17'-0"	16'-4"	15'-8"	19'-2"	17'-10"	17'-2"	16'-6"
11-7/8"	NI-20	17'-10"	16'-10"	16'-2"	15'-7"	19'-0"	17'-9"	17'-2"	16'-1"
	NI-40x	19'-3"	17'-10"	17'-2"	16'-6"	20'-6"	19'-1"	18'-3"	17'-0"
	NI-60	19'-6"	18'-1"	17'-4"	16'-8"	20'-9"	19'-4"	18'-6"	17'-8"
	NI-80	20'-11"	19'-4"	18'-5"	17'-7"	22'-3"	20'-8"	19'-8"	18'-8"
	NI-90	21'-4"	19'-9"	18'-9"	17'-10"	22'-8"	21'-1"	20'-1"	19'-0"
14"	NI-40x	21'-4"	19'-9"	18'-10"	17'-11"	22'-10"	21'-3"	20'-4"	18'-8"
	NI-60	21'-8"	20'-1"	19'-2"	18'-2"	23'-3"	21'-7"	20'-7"	19'-7"
	NI-80	23'-3"	21'-6"	20'-5"	19'-4"	24'-10"	23'-1"	22'-0"	20'-10"
	NI-90	23'-9"	21'-11"	20'-10"	19'-8"	25'-4"	23'-6"	22'-5"	21'-2"
16"	NI-60	23'-7"	21'-10"	20'-10"	19'-9"	25'-5"	23'-8"	22'-7"	21'-5"
	NI-80	25'-4"	23'-5"	22'-3"	21'-1"	27'-2"	25'-3"	24'-1"	22'-9"
	NI-90	25'-10"	23'-10"	22'-8"	21'-5"	27'-8"	25'-8"	24'-6"	23'-2"

Notes :

1. Les portées libres indiquées sont basées sur la norme CSA O86-14 et le CNB 2015 et s'appliquent à la construction de planchers résidentiels respectant les critères de conception ci-dessus.
2. Pour les portées multiples, les portées extérieures doivent être supérieures à 40% de la portée adjacente.
3. La longueur d'appui minimale est de 1-3/4 pouce pour les appuis d'extrémités et de 3-1/2 pouces pour les appuis intermédiaires.
4. Les raidisseurs d'appui ne sont pas requis lorsque les solives sont utilisées conformément à ce tableau, sauf si requis pour les étriers.

Portées maximales de plancher – M7.2, blocage à mi-portée

Critères de conception

Portées :	Portées multiples
Charges :	Surcharge = 40 lbf/pi ² et charge permanente = 20 lbf/pi ²
Limite de flèche :	L/240 sous la charge totale
Revêtement :	Contreplaqué de résineux canadiens 3/4 po, cloué et collé

Portées maximales de plancher

Limite de flèche de L/480 sous la surcharge

Hauteur	Série	Solive seule				Blocage à mi-portée			
		Espacement centre/centre				Espacement centre/centre			
		12"	16"	19,2"	24"	12"	16"	19,2"	24"
9-1/2"	NI-20	17'-1"	16'-1"	15'-7"	14'-0"	17'-10"	16'-9"	15'-8"	14'-0"
	NI-40x	18'-4"	17'-2"	16'-7"	14'-10"	19'-4"	18'-0"	16'-8"	14'-10"
	NI-60	18'-7"	17'-4"	16'-9"	16'-1"	19'-7"	18'-2"	17'-6"	16'-9"
	NI-80	20'-0"	18'-6"	17'-8"	16'-11"	21'-0"	19'-6"	18'-7"	17'-7"
11-7/8"	NI-20	19'-7"	18'-2"	17'-6"	16'-0"	20'-10"	19'-5"	17'-11"	16'-0"
	NI-40x	21'-2"	19'-8"	18'-9"	16'-11"	22'-6"	20'-10"	19'-0"	16'-11"
	NI-60	21'-6"	19'-11"	19'-0"	18'-0"	22'-10"	21'-2"	20'-3"	19'-3"
	NI-80	23'-1"	21'-4"	20'-4"	19'-3"	24'-5"	22'-8"	21'-7"	20'-6"
	NI-90	23'-7"	21'-9"	20'-9"	19'-8"	24'-11"	23'-1"	22'-1"	20'-11"
14"	NI-40x	23'-6"	21'-9"	20'-9"	18'-7"	25'-1"	22'-10"	20'-10"	18'-7"
	NI-60	23'-11"	22'-2"	21'-1"	20'-0"	25'-6"	23'-8"	22'-7"	21'-4"
	NI-80	25'-8"	23'-9"	22'-7"	21'-4"	27'-3"	25'-4"	24'-2"	22'-11"
	NI-90	26'-2"	24'-2"	23'-0"	21'-9"	27'-10"	25'-10"	24'-7"	23'-4"
16"	NI-60	26'-1"	24'-1"	23'-0"	21'-9"	27'-11"	25'-11"	24'-9"	23'-0"
	NI-80	27'-11"	25'-10"	24'-7"	23'-3"	29'-10"	27'-9"	26'-5"	25'-0"
	NI-90	28'-6"	26'-4"	25'-0"	23'-8"	30'-5"	28'-3"	26'-11"	25'-5"

Limite de flèche de L/360 sous la surcharge

Hauteur	Série	Solive seule				Blocage à mi-portée			
		Espacement centre/centre				Espacement centre/centre			
		12"	16"	19,2"	24"	12"	16"	19,2"	24"
9-1/2"	NI-20	17'-1"	16'-1"	15'-7"	14'-0"	17'-10"	16'-10"	15'-8"	14'-0"
	NI-40x	18'-4"	17'-2"	16'-7"	14'-10"	19'-4"	18'-0"	16'-8"	14'-10"
	NI-60	18'-7"	17'-4"	16'-9"	16'-1"	19'-7"	18'-2"	17'-6"	16'-10"
	NI-80	20'-0"	18'-6"	17'-8"	16'-11"	21'-0"	19'-6"	18'-7"	17'-7"
11-7/8"	NI-20	19'-7"	18'-2"	17'-6"	16'-0"	20'-10"	19'-5"	17'-11"	16'-0"
	NI-40x	21'-2"	19'-8"	18'-9"	16'-11"	22'-6"	20'-10"	19'-0"	16'-11"
	NI-60	21'-6"	19'-11"	19'-0"	18'-0"	22'-10"	21'-2"	20'-3"	19'-3"
	NI-80	23'-1"	21'-4"	20'-4"	19'-3"	24'-5"	22'-8"	21'-7"	20'-6"
	NI-90	23'-7"	21'-9"	20'-9"	19'-8"	24'-11"	23'-1"	22'-1"	20'-11"
14"	NI-40x	23'-6"	21'-9"	20'-9"	18'-7"	25'-1"	22'-10"	20'-10"	18'-7"
	NI-60	23'-11"	22'-2"	21'-1"	20'-0"	25'-6"	23'-8"	22'-7"	21'-4"
	NI-80	25'-8"	23'-9"	22'-7"	21'-4"	27'-3"	25'-4"	24'-2"	22'-11"
	NI-90	26'-2"	24'-2"	23'-0"	21'-9"	27'-10"	25'-10"	24'-7"	23'-4"
16"	NI-60	26'-1"	24'-1"	23'-0"	21'-9"	27'-11"	25'-11"	24'-9"	23'-0"
	NI-80	27'-11"	25'-10"	24'-7"	23'-3"	29'-10"	27'-9"	26'-5"	25'-0"
	NI-90	28'-6"	26'-4"	25'-0"	23'-8"	30'-5"	28'-3"	26'-11"	25'-5"

Notes :

1. Les portées libres indiquées sont basées sur la norme CSA O86-14 et le CNB 2015 et s'appliquent à la construction de planchers résidentiels respectant les critères de conception ci-dessus.
2. Pour les portées multiples, les portées extérieures doivent être supérieures à 40% de la portée adjacente.
3. La longueur d'appui minimale est de 1-3/4 pouce pour les appuis d'extrémités et de 3-1/2 pouces pour les appuis intermédiaires.
4. Les raidisseurs d'appui ne sont pas requis lorsque les solives sont utilisées conformément à ce tableau, sauf si requis pour les étriers.

Portées maximales de plancher – H1.1, blocage à mi-portée

Critères de conception

Portées :	Portée simple
Charges :	Surcharge = 40 lbf/pi ² et charge permanente = 35 lbf/pi ²
Limite de flèche :	L/240 sous la charge totale
Revêtement :	Panneaux de copeaux orientés (OSB) 19/32 po, cloué et collé

Portées maximales de plancher

Limite de flèche de L/480 sous la surcharge

Hauteur	Série	Solive seule				Blocage à mi-portée			
		Espacement centre/centre				Espacement centre/centre			
		12"	16"	19,2"	24"	12"	16"	19,2"	24"
9-1/2"	NI-20	14'-11"	14'-1"	13'-7"	-	15'-10"	15'-0"	14'-3"	-
	NI-40x	15'-11"	15'-0"	14'-6"	-	16'-11"	16'-0"	15'-1"	-
	NI-60	16'-1"	15'-2"	14'-8"	-	17'-1"	16'-1"	15'-7"	-
	NI-80	17'-0"	16'-0"	15'-6"	-	18'-0"	17'-0"	16'-5"	-
11-7/8"	NI-20	16'-9"	15'-10"	15'-4"	-	17'-11"	17'-0"	16'-3"	-
	NI-40x	17'-10"	16'-10"	16'-3"	-	19'-5"	18'-0"	17'-3"	-
	NI-60	18'-1"	17'-0"	16'-5"	-	19'-8"	18'-3"	17'-7"	-
	NI-80	19'-5"	17'-11"	17'-4"	-	21'-0"	19'-6"	18'-8"	-
	NI-90	19'-10"	18'-4"	17'-7"	-	21'-5"	19'-11"	19'-0"	-
14"	NI-40x	19'-9"	18'-4"	17'-8"	-	21'-8"	20'-1"	18'-11"	-
	NI-60	20'-1"	18'-7"	17'-10"	-	22'-0"	20'-5"	19'-7"	-
	NI-80	21'-7"	19'-11"	19'-1"	-	23'-6"	21'-10"	20'-10"	-
	NI-90	22'-0"	20'-4"	19'-5"	-	24'-0"	22'-3"	21'-3"	-
16"	NI-60	21'-11"	20'-4"	19'-5"	-	24'-2"	22'-5"	21'-6"	-
	NI-80	23'-6"	21'-9"	20'-9"	-	25'-10"	23'-11"	22'-10"	-
	NI-90	23'-11"	22'-1"	21'-2"	-	26'-3"	24'-4"	23'-3"	-

Limite de flèche de L/360 sous la surcharge

Hauteur	Série	Solive seule				Blocage à mi-portée			
		Espacement centre/centre				Espacement centre/centre			
		12"	16"	19,2"	24"	12"	16"	19,2"	24"
9-1/2"	NI-20	14'-11"	14'-1"	13'-7"	-	15'-10"	15'-0"	14'-3"	-
	NI-40x	15'-11"	15'-0"	14'-6"	-	16'-11"	16'-0"	15'-1"	-
	NI-60	16'-1"	15'-2"	14'-8"	-	17'-1"	16'-1"	15'-7"	-
	NI-80	17'-0"	16'-0"	15'-6"	-	18'-0"	17'-0"	16'-5"	-
11-7/8"	NI-20	16'-9"	15'-10"	15'-4"	-	17'-11"	17'-0"	16'-3"	-
	NI-40x	17'-10"	16'-10"	16'-3"	-	19'-5"	18'-0"	17'-3"	-
	NI-60	18'-1"	17'-0"	16'-5"	-	19'-8"	18'-3"	17'-7"	-
	NI-80	19'-5"	17'-11"	17'-4"	-	21'-0"	19'-6"	18'-8"	-
	NI-90	19'-10"	18'-4"	17'-7"	-	21'-5"	19'-11"	19'-0"	-
14"	NI-40x	19'-9"	18'-4"	17'-8"	-	21'-8"	20'-1"	18'-11"	-
	NI-60	20'-1"	18'-7"	17'-10"	-	22'-0"	20'-5"	19'-7"	-
	NI-80	21'-7"	19'-11"	19'-1"	-	23'-6"	21'-10"	20'-10"	-
	NI-90	22'-0"	20'-4"	19'-5"	-	24'-0"	22'-3"	21'-3"	-
16"	NI-60	21'-11"	20'-4"	19'-5"	-	24'-2"	22'-5"	21'-6"	-
	NI-80	23'-6"	21'-9"	20'-9"	-	25'-10"	23'-11"	22'-10"	-
	NI-90	23'-11"	22'-1"	21'-2"	-	26'-3"	24'-4"	23'-3"	-

Notes :

1. Les portées libres indiquées sont basées sur la norme CSA O86-14 et le CNB 2015 et s'appliquent à la construction de planchers résidentiels respectant les critères de conception ci-dessus.
2. Pour les portées multiples, les portées extérieures doivent être supérieures à 40% de la portée adjacente.
3. La longueur d'appui minimale est de 1-3/4 pouce pour les appuis d'extrémités et de 3-1/2 pouces pour les appuis intermédiaires.
4. Les raidisseurs d'appui ne sont pas requis lorsque les solives sont utilisées conformément à ce tableau, sauf si requis pour les étriers.

Portées maximales de plancher – H1.2, blocage à mi-portée

Critères de conception

Portées :	Portées multiples
Charges :	Surcharge = 40 lbf/pi ² et charge permanente = 35 lbf/pi ²
Limite de flèche :	L/240 sous la charge totale
Revêtement :	Panneaux de copeaux orientés (OSB) 19/32 po, cloué et collé

Portées maximales de plancher

Limite de flèche de L/480 sous la surcharge

Hauteur	Série	Solive seule				Blocage à mi-portée			
		Espacement centre/centre				Espacement centre/centre			
		12"	16"	19,2"	24"	12"	16"	19,2"	24"
9-1/2"	NI-20	16'-0"	15'-2"	14'-2"	-	17'-0"	15'-7"	14'-2"	-
	NI-40x	17'-2"	16'-2"	15'-0"	-	18'-2"	16'-6"	15'-0"	-
	NI-60	17'-4"	16'-4"	15'-10"	-	18'-5"	17'-4"	16'-9"	-
	NI-80	18'-6"	17'-4"	16'-9"	-	19'-9"	18'-4"	17'-8"	-
11-7/8"	NI-20	18'-1"	17'-1"	16'-2"	-	19'-8"	17'-9"	16'-2"	-
	NI-40x	19'-8"	18'-3"	17'-2"	-	21'-3"	18'-10"	17'-2"	-
	NI-60	19'-11"	18'-6"	17'-9"	-	21'-6"	20'-0"	19'-2"	-
	NI-80	21'-5"	19'-10"	19'-0"	-	23'-1"	21'-5"	20'-6"	-
14"	NI-90	21'-11"	20'-3"	19'-4"	-	23'-7"	21'-10"	20'-11"	-
	NI-40x	21'-9"	20'-3"	18'-10"	-	23'-9"	20'-8"	18'-10"	-
	NI-60	22'-2"	20'-7"	19'-8"	-	24'-1"	22'-5"	21'-6"	-
	NI-80	23'-10"	22'-0"	21'-1"	-	25'-10"	23'-11"	22'-11"	-
16"	NI-90	24'-4"	22'-6"	21'-6"	-	26'-4"	24'-5"	23'-4"	-
	NI-60	24'-2"	22'-5"	21'-5"	-	26'-5"	24'-7"	23'-4"	-
	NI-80	26'-0"	24'-0"	22'-11"	-	28'-4"	26'-3"	25'-1"	-
	NI-90	26'-6"	24'-5"	23'-4"	-	28'-10"	26'-8"	25'-6"	-

Limite de flèche de L/360 sous la surcharge

Hauteur	Série	Solive seule				Blocage à mi-portée			
		Espacement centre/centre				Espacement centre/centre			
		12"	16"	19,2"	24"	12"	16"	19,2"	24"
9-1/2"	NI-20	16'-0"	15'-2"	14'-2"	-	17'-0"	15'-7"	14'-2"	-
	NI-40x	17'-2"	16'-2"	15'-0"	-	18'-2"	16'-6"	15'-0"	-
	NI-60	17'-4"	16'-4"	15'-10"	-	18'-5"	17'-4"	16'-9"	-
	NI-80	18'-6"	17'-4"	16'-9"	-	19'-9"	18'-4"	17'-8"	-
11-7/8"	NI-20	18'-1"	17'-1"	16'-2"	-	19'-8"	17'-9"	16'-2"	-
	NI-40x	19'-8"	18'-3"	17'-2"	-	21'-3"	18'-10"	17'-2"	-
	NI-60	19'-11"	18'-6"	17'-9"	-	21'-6"	20'-0"	19'-2"	-
	NI-80	21'-5"	19'-10"	19'-0"	-	23'-1"	21'-5"	20'-6"	-
14"	NI-90	21'-11"	20'-3"	19'-4"	-	23'-7"	21'-10"	20'-11"	-
	NI-40x	21'-9"	20'-3"	18'-10"	-	23'-9"	20'-8"	18'-10"	-
	NI-60	22'-2"	20'-7"	19'-8"	-	24'-1"	22'-5"	21'-6"	-
	NI-80	23'-10"	22'-0"	21'-1"	-	25'-10"	23'-11"	22'-11"	-
16"	NI-90	24'-4"	22'-6"	21'-6"	-	26'-4"	24'-5"	23'-4"	-
	NI-60	24'-2"	22'-5"	21'-5"	-	26'-5"	24'-7"	23'-4"	-
	NI-80	26'-0"	24'-0"	22'-11"	-	28'-4"	26'-3"	25'-1"	-
	NI-90	26'-6"	24'-5"	23'-4"	-	28'-10"	26'-8"	25'-6"	-

Notes :

1. Les portées libres indiquées sur la norme CSA O86-14 et le CNB 2015 et s'appliquent à la construction de planchers résidentiels respectant les critères de conception ci-dessus.
2. Pour les portées multiples, les portées extérieures doivent être supérieures à 40% de la portée adjacente.
3. La longueur d'appui minimale est de 1-3/4 pouce pour les appuis d'extrémités et de 3-1/2 pouces pour les appuis intermédiaires.
4. Les raidisseurs d'appui ne sont pas requis lorsque les solives sont utilisées conformément à ce tableau, sauf si requis pour les étriers.

Portées maximales de plancher – H2.1, blocage à mi-portée

Critères de conception

Portées :	Portée simple
Charges :	Surcharge = 40 lbf/pi ² et charge permanente = 35 lbf/pi ²
Limite de flèche :	L/240 sous la charge totale
Revêtement :	Panneaux de copeaux orientés (OSB) 5/8 po, cloué et collé

Portées maximales de plancher

Limite de flèche de L/480 sous la surcharge

Hauteur	Série	Solive seule				Blocage à mi-portée			
		Espacement centre/centre				Espacement centre/centre			
		12"	16"	19,2"	24"	12"	16"	19,2"	24"
9-1/2"	NI-20	15'-1"	14'-3"	13'-10"	-	16'-1"	15'-2"	14'-3"	-
	NI-40x	16'-2"	15'-3"	14'-8"	-	17'-1"	16'-2"	15'-1"	-
	NI-60	16'-4"	15'-4"	14'-10"	-	17'-3"	16'-4"	15'-9"	-
	NI-80	17'-3"	16'-3"	15'-8"	-	18'-3"	17'-2"	16'-7"	-
11-7/8"	NI-20	17'-0"	16'-0"	15'-6"	-	18'-2"	17'-2"	16'-3"	-
	NI-40x	18'-2"	17'-1"	16'-6"	-	19'-8"	18'-3"	17'-3"	-
	NI-60	18'-5"	17'-3"	16'-8"	-	19'-11"	18'-6"	17'-9"	-
	NI-80	19'-9"	18'-3"	17'-7"	-	21'-4"	19'-9"	18'-11"	-
14"	NI-90	20'-2"	18'-8"	17'-10"	-	21'-9"	20'-2"	19'-3"	-
	NI-40x	20'-1"	18'-8"	17'-10"	-	21'-11"	20'-5"	18'-11"	-
	NI-60	20'-6"	18'-11"	18'-2"	-	22'-3"	20'-8"	19'-10"	-
	NI-80	21'-11"	20'-3"	19'-4"	-	23'-10"	22'-1"	21'-1"	-
16"	NI-90	22'-5"	20'-8"	19'-9"	-	24'-4"	22'-6"	21'-6"	-
	NI-60	22'-4"	20'-8"	19'-9"	-	24'-5"	22'-8"	21'-8"	-
	NI-80	23'-11"	22'-1"	21'-1"	-	26'-2"	24'-2"	23'-1"	-
	NI-90	24'-5"	22'-6"	21'-6"	-	26'-7"	24'-8"	23'-6"	-

Limite de flèche de L/360 sous la surcharge

Hauteur	Série	Solive seule				Blocage à mi-portée			
		Espacement centre/centre				Espacement centre/centre			
		12"	16"	19,2"	24"	12"	16"	19,2"	24"
9-1/2"	NI-20	15'-1"	14'-3"	13'-10"	-	16'-1"	15'-2"	14'-3"	-
	NI-40x	16'-2"	15'-3"	14'-8"	-	17'-1"	16'-2"	15'-1"	-
	NI-60	16'-4"	15'-4"	14'-10"	-	17'-3"	16'-4"	15'-9"	-
	NI-80	17'-3"	16'-3"	15'-8"	-	18'-3"	17'-2"	16'-7"	-
11-7/8"	NI-20	17'-0"	16'-0"	15'-6"	-	18'-2"	17'-2"	16'-3"	-
	NI-40x	18'-2"	17'-1"	16'-6"	-	19'-8"	18'-3"	17'-3"	-
	NI-60	18'-5"	17'-3"	16'-8"	-	19'-11"	18'-6"	17'-9"	-
	NI-80	19'-9"	18'-3"	17'-7"	-	21'-4"	19'-9"	18'-11"	-
14"	NI-90	20'-2"	18'-8"	17'-10"	-	21'-9"	20'-2"	19'-3"	-
	NI-40x	20'-1"	18'-8"	17'-10"	-	21'-11"	20'-5"	18'-11"	-
	NI-60	20'-6"	18'-11"	18'-2"	-	22'-3"	20'-8"	19'-10"	-
	NI-80	21'-11"	20'-3"	19'-4"	-	23'-10"	22'-1"	21'-1"	-
16"	NI-90	22'-5"	20'-8"	19'-9"	-	24'-4"	22'-6"	21'-6"	-
	NI-60	22'-4"	20'-8"	19'-9"	-	24'-5"	22'-8"	21'-8"	-
	NI-80	23'-11"	22'-1"	21'-1"	-	26'-2"	24'-2"	23'-1"	-
	NI-90	24'-5"	22'-6"	21'-6"	-	26'-7"	24'-8"	23'-6"	-

Notes :

1. Les portées libres indiquées sur la norme CSA O86-14 et le CNB 2015 et s'appliquent à la construction de planchers résidentiels respectant les critères de conception ci-dessus.
2. Pour les portées multiples, les portées extérieures doivent être supérieures à 40% de la portée adjacente.
3. La longueur d'appui minimale est de 1-3/4 pouce pour les appuis d'extrémités et de 3-1/2 pouces pour les appuis intermédiaires.
4. Les raidisseurs d'appui ne sont pas requis lorsque les solives sont utilisées conformément à ce tableau, sauf si requis pour les étriers.

Portées maximales de plancher – H2.2, blocage à mi-portée

Critères de conception

Portées :	Portées multiples
Charges :	Surcharge = 40 lbf/pi ² et charge permanente = 35 lbf/pi ²
Limite de flèche :	L/240 sous la charge totale
Revêtement :	Panneaux de copeaux orientés (OSB) 5/8 po, cloué et collé

Portées maximales de plancher

Limite de flèche de L/480 sous la surcharge

Hauteur	Série	Solive seule				Blocage à mi-portée			
		Espacement centre/centre				Espacement centre/centre			
		12"	16"	19,2"	24"	12"	16"	19,2"	24"
9-1/2"	NI-20	16'-3"	15'-4"	14'-2"	-	17'-2"	15'-7"	14'-2"	-
	NI-40x	17'-5"	16'-5"	15'-0"	-	18'-5"	16'-6"	15'-0"	-
	NI-60	17'-7"	16'-7"	16'-0"	-	18'-8"	17'-6"	16'-11"	-
	NI-80	18'-10"	17'-6"	16'-11"	-	20'-1"	18'-8"	17'-10"	-
11-7/8"	NI-20	18'-5"	17'-3"	16'-2"	-	19'-11"	17'-9"	16'-2"	-
	NI-40x	20'-0"	18'-7"	17'-2"	-	21'-6"	18'-10"	17'-2"	-
	NI-60	20'-3"	18'-10"	18'-0"	-	21'-10"	20'-3"	19'-5"	-
	NI-80	21'-10"	20'-2"	19'-3"	-	23'-5"	21'-8"	20'-9"	-
14"	NI-90	22'-3"	20'-7"	19'-8"	-	23'-10"	22'-1"	21'-2"	-
	NI-40x	22'-2"	20'-7"	18'-10"	-	23'-11"	20'-8"	18'-10"	-
	NI-60	22'-7"	20'-11"	20'-0"	-	24'-5"	22'-8"	21'-7"	-
	NI-80	24'-3"	22'-5"	21'-5"	-	26'-2"	24'-3"	23'-2"	-
16"	NI-90	24'-9"	22'-10"	21'-10"	-	26'-8"	24'-9"	23'-7"	-
	NI-60	24'-7"	22'-10"	21'-9"	-	26'-10"	24'-11"	23'-4"	-
	NI-80	26'-5"	24'-5"	23'-4"	-	28'-8"	26'-7"	25'-4"	-
	NI-90	26'-11"	24'-11"	23'-9"	-	29'-3"	27'-1"	25'-10"	-

Limite de flèche de L/360 sous la surcharge

Hauteur	Série	Solive seule				Blocage à mi-portée			
		Espacement centre/centre				Espacement centre/centre			
		12"	16"	19,2"	24"	12"	16"	19,2"	24"
9-1/2"	NI-20	16'-3"	15'-4"	14'-2"	-	17'-2"	15'-7"	14'-2"	-
	NI-40x	17'-5"	16'-5"	15'-0"	-	18'-5"	16'-6"	15'-0"	-
	NI-60	17'-7"	16'-7"	16'-0"	-	18'-8"	17'-6"	16'-11"	-
	NI-80	18'-10"	17'-6"	16'-11"	-	20'-1"	18'-8"	17'-10"	-
11-7/8"	NI-20	18'-5"	17'-3"	16'-2"	-	19'-11"	17'-9"	16'-2"	-
	NI-40x	20'-0"	18'-7"	17'-2"	-	21'-6"	18'-10"	17'-2"	-
	NI-60	20'-3"	18'-10"	18'-0"	-	21'-10"	20'-3"	19'-5"	-
	NI-80	21'-10"	20'-2"	19'-3"	-	23'-5"	21'-8"	20'-9"	-
14"	NI-90	22'-3"	20'-7"	19'-8"	-	23'-10"	22'-1"	21'-2"	-
	NI-40x	22'-2"	20'-7"	18'-10"	-	23'-11"	20'-8"	18'-10"	-
	NI-60	22'-7"	20'-11"	20'-0"	-	24'-5"	22'-8"	21'-7"	-
	NI-80	24'-3"	22'-5"	21'-5"	-	26'-2"	24'-3"	23'-2"	-
16"	NI-90	24'-9"	22'-10"	21'-10"	-	26'-8"	24'-9"	23'-7"	-
	NI-60	24'-7"	22'-10"	21'-9"	-	26'-10"	24'-11"	23'-4"	-
	NI-80	26'-5"	24'-5"	23'-4"	-	28'-8"	26'-7"	25'-4"	-
	NI-90	26'-11"	24'-11"	23'-9"	-	29'-3"	27'-1"	25'-10"	-

Notes :

1. Les portées libres indiquées sont basées sur la norme CSA O86-14 et le CNB 2015 et s'appliquent à la construction de planchers résidentiels respectant les critères de conception ci-dessus.
2. Pour les portées multiples, les portées extérieures doivent être supérieures à 40% de la portée adjacente.
3. La longueur d'appui minimale est de 1-3/4 pouce pour les appuis d'extrémités et de 3-1/2 pouces pour les appuis intermédiaires.
4. Les raidisseurs d'appui ne sont pas requis lorsque les solives sont utilisées conformément à ce tableau, sauf si requis pour les étriers.

Portées maximales de plancher – H3.1, blocage à mi-portée

Critères de conception

Portées :	Portée simple
Charges :	Surcharge = 40 lbf/pi ² et charge permanente = 35 lbf/pi ²
Limite de flèche :	L/240 sous la charge totale
Revêtement :	Panneaux de copeaux orientés (OSB) 23/32 po, cloué et collé

Portées maximales de plancher

Limite de flèche de L/480 sous la surcharge

Hauteur	Série	Solive seule				Blocage à mi-portée			
		Espacement centre/centre				Espacement centre/centre			
		12"	16"	19,2"	24"	12"	16"	19,2"	24"
9-1/2"	NI-20	15'-9"	14'-10"	14'-3"	12'-9"	16'-7"	15'-4"	14'-3"	12'-9"
	NI-40x	16'-10"	15'-10"	15'-1"	13'-6"	17'-7"	16'-7"	15'-1"	13'-6"
	NI-60	16'-11"	16'-0"	15'-5"	14'-9"	17'-9"	16'-10"	16'-3"	15'-4"
	NI-80	18'-0"	16'-11"	16'-3"	15'-7"	19'-0"	17'-8"	17'-1"	16'-5"
11-7/8"	NI-20	17'-8"	16'-8"	16'-1"	14'-6"	18'-11"	17'-8"	16'-3"	14'-6"
	NI-40x	19'-1"	17'-9"	17'-1"	15'-5"	20'-5"	18'-10"	17'-3"	15'-5"
	NI-60	19'-4"	17'-11"	17'-3"	16'-7"	20'-8"	19'-2"	18'-4"	17'-7"
	NI-80	20'-9"	19'-2"	18'-3"	17'-5"	22'-1"	20'-6"	19'-7"	18'-7"
	NI-90	21'-2"	19'-7"	18'-8"	17'-9"	22'-7"	20'-11"	19'-11"	18'-11"
14"	NI-40x	21'-2"	19'-7"	18'-8"	16'-11"	22'-9"	20'-9"	18'-11"	16'-11"
	NI-60	21'-6"	19'-11"	19'-0"	18'-0"	23'-1"	21'-6"	20'-6"	19'-5"
	NI-80	23'-1"	21'-4"	20'-3"	19'-3"	24'-8"	22'-11"	21'-10"	20'-9"
	NI-90	23'-6"	21'-9"	20'-8"	19'-7"	25'-2"	23'-4"	22'-3"	21'-1"
16"	NI-60	23'-5"	21'-8"	20'-8"	19'-7"	25'-4"	23'-6"	22'-5"	20'-11"
	NI-80	25'-1"	23'-2"	22'-1"	20'-11"	27'-0"	25'-1"	23'-11"	22'-8"
	NI-90	25'-7"	23'-7"	22'-6"	21'-3"	27'-6"	25'-6"	24'-4"	23'-0"

Limite de flèche de L/360 sous la surcharge

Hauteur	Série	Solive seule				Blocage à mi-portée			
		Espacement centre/centre				Espacement centre/centre			
		12"	16"	19,2"	24"	12"	16"	19,2"	24"
9-1/2"	NI-20	15'-9"	14'-10"	14'-3"	12'-9"	16'-7"	15'-5"	14'-3"	12'-9"
	NI-40x	16'-10"	15'-10"	15'-1"	13'-6"	17'-7"	16'-7"	15'-1"	13'-6"
	NI-60	16'-11"	16'-0"	15'-5"	14'-9"	17'-9"	16'-10"	16'-3"	15'-6"
	NI-80	18'-0"	16'-11"	16'-3"	15'-7"	19'-0"	17'-8"	17'-1"	16'-5"
11-7/8"	NI-20	17'-8"	16'-8"	16'-1"	14'-6"	18'-11"	17'-8"	16'-3"	14'-6"
	NI-40x	19'-1"	17'-9"	17'-1"	15'-5"	20'-5"	18'-10"	17'-3"	15'-5"
	NI-60	19'-4"	17'-11"	17'-3"	16'-7"	20'-8"	19'-2"	18'-4"	17'-7"
	NI-80	20'-9"	19'-2"	18'-3"	17'-5"	22'-1"	20'-6"	19'-7"	18'-7"
	NI-90	21'-2"	19'-7"	18'-8"	17'-9"	22'-7"	20'-11"	19'-11"	18'-11"
14"	NI-40x	21'-2"	19'-7"	18'-8"	16'-11"	22'-9"	20'-9"	18'-11"	16'-11"
	NI-60	21'-6"	19'-11"	19'-0"	18'-0"	23'-1"	21'-6"	20'-6"	19'-5"
	NI-80	23'-1"	21'-4"	20'-3"	19'-3"	24'-8"	22'-11"	21'-10"	20'-9"
	NI-90	23'-6"	21'-9"	20'-8"	19'-7"	25'-2"	23'-4"	22'-3"	21'-1"
16"	NI-60	23'-5"	21'-8"	20'-8"	19'-7"	25'-4"	23'-6"	22'-5"	20'-11"
	NI-80	25'-1"	23'-2"	22'-1"	20'-11"	27'-0"	25'-1"	23'-11"	22'-8"
	NI-90	25'-7"	23'-7"	22'-6"	21'-3"	27'-6"	25'-6"	24'-4"	23'-0"

Notes :

1. Les portées libres indiquées sur la norme CSA O86-14 et le CNB 2015 et s'appliquent à la construction de planchers résidentiels respectant les critères de conception ci-dessus.
2. Pour les portées multiples, les portées extérieures doivent être supérieures à 40% de la portée adjacente.
3. La longueur d'appui minimale est de 1-3/4 pouce pour les appuis d'extrémités et de 3-1/2 pouces pour les appuis intermédiaires.
4. Les raidisseurs d'appui ne sont pas requis lorsque les solives sont utilisées conformément à ce tableau, sauf si requis pour les étriers.

Portées maximales de plancher – H3.2, blocage à mi-portée

Critères de conception

Portées :	Portées multiples
Charges :	Surcharge = 40 lbf/pi ² et charge permanente = 35 lbf/pi ²
Limite de flèche :	L/240 sous la charge totale
Revêtement :	Panneaux de copeaux orientés (OSB) 23/32 po, cloué et collé

Portées maximales de plancher

Limite de flèche de L/480 sous la surcharge

Hauteur	Série	Solive seule				Blocage à mi-portée			
		Espacement centre/centre				Espacement centre/centre			
		12"	16"	19,2"	24"	12"	16"	19,2"	24"
9-1/2"	NI-20	16'-11"	15'-7"	14'-2"	12'-8"	17'-9"	15'-7"	14'-2"	12'-8"
	NI-40x	18'-2"	16'-6"	15'-0"	13'-5"	19'-1"	16'-6"	15'-0"	13'-5"
	NI-60	18'-5"	17'-3"	16'-7"	14'-4"	19'-5"	18'-1"	17'-3"	14'-4"
	NI-80	19'-10"	18'-4"	17'-7"	14'-4"	20'-10"	19'-4"	18'-0"	14'-4"
11-7/8"	NI-20	19'-5"	17'-9"	16'-2"	14'-5"	20'-6"	17'-9"	16'-2"	14'-5"
	NI-40x	21'-0"	18'-10"	17'-2"	15'-4"	21'-9"	18'-10"	17'-2"	15'-4"
	NI-60	21'-4"	19'-9"	18'-10"	17'-7"	22'-8"	21'-1"	19'-8"	17'-7"
	NI-80	22'-11"	21'-2"	20'-2"	17'-10"	24'-3"	22'-6"	21'-6"	17'-10"
	NI-90	23'-5"	21'-7"	20'-7"	19'-6"	24'-9"	23'-0"	21'-11"	20'-3"
14"	NI-40x	23'-4"	20'-8"	18'-10"	16'-10"	23'-11"	20'-8"	18'-10"	16'-10"
	NI-60	23'-8"	21'-11"	20'-11"	18'-11"	25'-4"	23'-7"	21'-7"	18'-11"
	NI-80	25'-5"	23'-6"	22'-5"	20'-1"	27'-1"	25'-2"	24'-0"	20'-1"
	NI-90	26'-0"	24'-0"	22'-10"	20'-3"	27'-8"	25'-8"	24'-5"	20'-3"
16"	NI-60	25'-10"	23'-11"	22'-10"	19'-8"	27'-9"	25'-6"	23'-4"	19'-8"
	NI-80	27'-9"	25'-7"	24'-5"	21'-11"	29'-8"	27'-7"	26'-3"	21'-11"
	NI-90	28'-3"	26'-1"	24'-10"	21'-11"	30'-3"	28'-1"	26'-9"	21'-11"

Limite de flèche de L/360 sous la surcharge

Hauteur	Série	Solive seule				Blocage à mi-portée			
		Espacement centre/centre				Espacement centre/centre			
		12"	16"	19,2"	24"	12"	16"	19,2"	24"
9-1/2"	NI-20	16'-11"	15'-7"	14'-2"	12'-8"	17'-9"	15'-7"	14'-2"	12'-8"
	NI-40x	18'-2"	16'-6"	15'-0"	13'-5"	19'-1"	16'-6"	15'-0"	13'-5"
	NI-60	18'-5"	17'-3"	16'-7"	14'-4"	19'-5"	18'-1"	17'-3"	14'-4"
	NI-80	19'-10"	18'-4"	17'-7"	14'-4"	20'-10"	19'-4"	18'-0"	14'-4"
11-7/8"	NI-20	19'-5"	17'-9"	16'-2"	14'-5"	20'-6"	17'-9"	16'-2"	14'-5"
	NI-40x	21'-0"	18'-10"	17'-2"	15'-4"	21'-9"	18'-10"	17'-2"	15'-4"
	NI-60	21'-4"	19'-9"	18'-10"	17'-7"	22'-8"	21'-1"	19'-8"	17'-7"
	NI-80	22'-11"	21'-2"	20'-2"	17'-10"	24'-3"	22'-6"	21'-6"	17'-10"
	NI-90	23'-5"	21'-7"	20'-7"	19'-6"	24'-9"	23'-0"	21'-11"	20'-3"
14"	NI-40x	23'-4"	20'-8"	18'-10"	16'-10"	23'-11"	20'-8"	18'-10"	16'-10"
	NI-60	23'-8"	21'-11"	20'-11"	18'-11"	25'-4"	23'-7"	21'-7"	18'-11"
	NI-80	25'-5"	23'-6"	22'-5"	20'-1"	27'-1"	25'-2"	24'-0"	20'-1"
	NI-90	26'-0"	24'-0"	22'-10"	20'-3"	27'-8"	25'-8"	24'-5"	20'-3"
16"	NI-60	25'-10"	23'-11"	22'-10"	19'-8"	27'-9"	25'-6"	23'-4"	19'-8"
	NI-80	27'-9"	25'-7"	24'-5"	21'-11"	29'-8"	27'-7"	26'-3"	21'-11"
	NI-90	28'-3"	26'-1"	24'-10"	21'-11"	30'-3"	28'-1"	26'-9"	21'-11"

Notes :

1. Les portées libres indiquées sont basées sur la norme CSA O86-14 et le CNB 2015 et s'appliquent à la construction de planchers résidentiels respectant les critères de conception ci-dessus.
2. Pour les portées multiples, les portées extérieures doivent être supérieures à 40% de la portée adjacente.
3. La longueur d'appui minimale est de 1-3/4 pouce pour les appuis d'extrémités et de 3-1/2 pouces pour les appuis intermédiaires.
4. Les raidisseurs d'appui ne sont pas requis lorsque les solives sont utilisées conformément à ce tableau, sauf si requis pour les étriers.

Portées maximales de plancher – H4.1, blocage à mi-portée

Critères de conception

Portées :	Portée simple
Charges :	Surcharge = 40 lbf/pi ² et charge permanente = 35 lbf/pi ²
Limite de flèche :	L/240 sous la charge totale
Revêtement :	Panneaux de copeaux orientés (OSB) 3/4 po, cloué et collé

Portées maximales de plancher

Limite de flèche de L/480 sous la surcharge

Hauteur	Série	Solive seule				Blocage à mi-portée			
		Espacement centre/centre				Espacement centre/centre			
		12"	16"	19,2"	24"	12"	16"	19,2"	24"
9-1/2"	NI-20	15'-11"	15'-0"	14'-3"	12'-9"	16'-8"	15'-5"	14'-3"	12'-9"
	NI-40x	17'-0"	16'-0"	15'-1"	13'-6"	17'-9"	16'-7"	15'-1"	13'-6"
	NI-60	17'-2"	16'-2"	15'-7"	14'-11"	17'-11"	16'-11"	16'-4"	15'-5"
	NI-80	18'-3"	17'-1"	16'-5"	15'-9"	19'-3"	17'-10"	17'-3"	16'-6"
11-7/8"	NI-20	17'-11"	16'-11"	16'-3"	14'-6"	19'-1"	17'-10"	16'-3"	14'-6"
	NI-40x	19'-4"	17'-11"	17'-3"	15'-5"	20'-7"	18'-10"	17'-3"	15'-5"
	NI-60	19'-7"	18'-2"	17'-6"	16'-9"	20'-11"	19'-5"	18'-7"	17'-8"
	NI-80	21'-1"	19'-6"	18'-6"	17'-7"	22'-4"	20'-9"	19'-9"	18'-9"
	NI-90	21'-6"	19'-10"	18'-11"	17'-11"	22'-10"	21'-2"	20'-2"	19'-1"
14"	NI-40x	21'-5"	19'-11"	18'-11"	16'-11"	23'-0"	20'-9"	18'-11"	16'-11"
	NI-60	21'-10"	20'-2"	19'-3"	18'-3"	23'-4"	21'-9"	20'-9"	19'-5"
	NI-80	23'-5"	21'-7"	20'-7"	19'-5"	25'-0"	23'-2"	22'-1"	20'-11"
	NI-90	23'-10"	22'-1"	21'-0"	19'-10"	25'-5"	23'-7"	22'-6"	21'-4"
16"	NI-60	23'-9"	22'-0"	21'-0"	19'-10"	25'-7"	23'-9"	22'-8"	20'-11"
	NI-80	25'-6"	23'-7"	22'-5"	21'-2"	27'-4"	25'-4"	24'-2"	22'-10"
	NI-90	26'-0"	24'-0"	22'-10"	21'-6"	27'-10"	25'-10"	24'-7"	23'-3"

Limite de flèche de L/360 sous la surcharge

Hauteur	Série	Solive seule				Blocage à mi-portée			
		Espacement centre/centre				Espacement centre/centre			
		12"	16"	19,2"	24"	12"	16"	19,2"	24"
9-1/2"	NI-20	15'-11"	15'-0"	14'-3"	12'-9"	16'-8"	15'-5"	14'-3"	12'-9"
	NI-40x	17'-0"	16'-0"	15'-1"	13'-6"	17'-9"	16'-7"	15'-1"	13'-6"
	NI-60	17'-2"	16'-2"	15'-7"	14'-11"	17'-11"	16'-11"	16'-4"	15'-6"
	NI-80	18'-3"	17'-1"	16'-5"	15'-9"	19'-3"	17'-10"	17'-3"	16'-6"
11-7/8"	NI-20	17'-11"	16'-11"	16'-3"	14'-6"	19'-1"	17'-10"	16'-3"	14'-6"
	NI-40x	19'-4"	17'-11"	17'-3"	15'-5"	20'-7"	18'-10"	17'-3"	15'-5"
	NI-60	19'-7"	18'-2"	17'-6"	16'-9"	20'-11"	19'-5"	18'-7"	17'-8"
	NI-80	21'-1"	19'-6"	18'-6"	17'-7"	22'-4"	20'-9"	19'-9"	18'-9"
	NI-90	21'-6"	19'-10"	18'-11"	17'-11"	22'-10"	21'-2"	20'-2"	19'-1"
14"	NI-40x	21'-5"	19'-11"	18'-11"	16'-11"	23'-0"	20'-9"	18'-11"	16'-11"
	NI-60	21'-10"	20'-2"	19'-3"	18'-3"	23'-4"	21'-9"	20'-9"	19'-5"
	NI-80	23'-5"	21'-7"	20'-7"	19'-5"	25'-0"	23'-2"	22'-1"	20'-11"
	NI-90	23'-10"	22'-1"	21'-0"	19'-10"	25'-5"	23'-7"	22'-6"	21'-4"
16"	NI-60	23'-9"	22'-0"	21'-0"	19'-10"	25'-7"	23'-9"	22'-8"	20'-11"
	NI-80	25'-6"	23'-7"	22'-5"	21'-2"	27'-4"	25'-4"	24'-2"	22'-10"
	NI-90	26'-0"	24'-0"	22'-10"	21'-6"	27'-10"	25'-10"	24'-7"	23'-3"

Notes :

1. Les portées libres indiquées sont basées sur la norme CSA O86-14 et le CNB 2015 et s'appliquent à la construction de planchers résidentiels respectant les critères de conception ci-dessus.
2. Pour les portées multiples, les portées extérieures doivent être supérieures à 40% de la portée adjacente.
3. La longueur d'appui minimale est de 1-3/4 pouce pour les appuis d'extrémités et de 3-1/2 pouces pour les appuis intermédiaires.
4. Les raidisseurs d'appui ne sont pas requis lorsque les solives sont utilisées conformément à ce tableau, sauf si requis pour les étriers.

Portées maximales de plancher – H4.2, blocage à mi-portée

Critères de conception

Portées :	Portées multiples
Charges :	Surcharge = 40 lbf/pi ² et charge permanente = 35 lbf/pi ²
Limite de flèche :	L/240 sous la charge totale
Revêtement :	Panneaux de copeaux orientés (OSB) 3/4 po, cloué et collé

Portées maximales de plancher

Limite de flèche de L/480 sous la surcharge

Hauteur	Série	Solive seule				Blocage à mi-portée			
		Espacement centre/centre				Espacement centre/centre			
		12"	16"	19,2"	24"	12"	16"	19,2"	24"
9-1/2"	NI-20	17'-2"	15'-7"	14'-2"	12'-8"	17'-11"	15'-7"	14'-2"	12'-8"
	NI-40x	18'-5"	16'-6"	15'-0"	13'-5"	19'-1"	16'-6"	15'-0"	13'-5"
	NI-60	18'-8"	17'-5"	16'-10"	14'-4"	19'-8"	18'-4"	17'-3"	14'-4"
	NI-80	20'-1"	18'-7"	17'-9"	14'-4"	21'-1"	19'-7"	18'-0"	14'-4"
11-7/8"	NI-20	19'-8"	17'-9"	16'-2"	14'-5"	20'-6"	17'-9"	16'-2"	14'-5"
	NI-40x	21'-4"	18'-10"	17'-2"	15'-4"	21'-9"	18'-10"	17'-2"	15'-4"
	NI-60	21'-8"	20'-1"	19'-1"	17'-7"	22'-11"	21'-4"	19'-8"	17'-7"
	NI-80	23'-3"	21'-6"	20'-5"	17'-10"	24'-6"	22'-9"	21'-9"	17'-10"
	NI-90	23'-9"	21'-11"	20'-10"	19'-9"	25'-1"	23'-3"	22'-2"	20'-3"
14"	NI-40x	23'-8"	20'-8"	18'-10"	16'-10"	23'-11"	20'-8"	18'-10"	16'-10"
	NI-60	24'-1"	22'-3"	21'-3"	18'-11"	25'-7"	23'-8"	21'-7"	18'-11"
	NI-80	25'-10"	23'-10"	22'-9"	20'-1"	27'-5"	25'-5"	24'-3"	20'-1"
	NI-90	26'-4"	24'-4"	23'-2"	20'-3"	27'-11"	25'-11"	24'-9"	20'-3"
16"	NI-60	26'-3"	24'-3"	23'-2"	19'-8"	28'-1"	25'-6"	23'-4"	19'-8"
	NI-80	28'-2"	26'-0"	24'-9"	21'-11"	30'-0"	27'-10"	26'-7"	21'-11"
	NI-90	28'-8"	26'-6"	25'-2"	21'-11"	30'-7"	28'-4"	27'-0"	21'-11"

Limite de flèche de L/360 sous la surcharge

Hauteur	Série	Solive seule				Blocage à mi-portée			
		Espacement centre/centre				Espacement centre/centre			
		12"	16"	19,2"	24"	12"	16"	19,2"	24"
9-1/2"	NI-20	17'-2"	15'-7"	14'-2"	12'-8"	17'-11"	15'-7"	14'-2"	12'-8"
	NI-40x	18'-5"	16'-6"	15'-0"	13'-5"	19'-1"	16'-6"	15'-0"	13'-5"
	NI-60	18'-8"	17'-5"	16'-10"	14'-4"	19'-8"	18'-4"	17'-3"	14'-4"
	NI-80	20'-1"	18'-7"	17'-9"	14'-4"	21'-1"	19'-7"	18'-0"	14'-4"
11-7/8"	NI-20	19'-8"	17'-9"	16'-2"	14'-5"	20'-6"	17'-9"	16'-2"	14'-5"
	NI-40x	21'-4"	18'-10"	17'-2"	15'-4"	21'-9"	18'-10"	17'-2"	15'-4"
	NI-60	21'-8"	20'-1"	19'-1"	17'-7"	22'-11"	21'-4"	19'-8"	17'-7"
	NI-80	23'-3"	21'-6"	20'-5"	17'-10"	24'-6"	22'-9"	21'-9"	17'-10"
	NI-90	23'-9"	21'-11"	20'-10"	19'-9"	25'-1"	23'-3"	22'-2"	20'-3"
14"	NI-40x	23'-8"	20'-8"	18'-10"	16'-10"	23'-11"	20'-8"	18'-10"	16'-10"
	NI-60	24'-1"	22'-3"	21'-3"	18'-11"	25'-7"	23'-8"	21'-7"	18'-11"
	NI-80	25'-10"	23'-10"	22'-9"	20'-1"	27'-5"	25'-5"	24'-3"	20'-1"
	NI-90	26'-4"	24'-4"	23'-2"	20'-3"	27'-11"	25'-11"	24'-9"	20'-3"
16"	NI-60	26'-3"	24'-3"	23'-2"	19'-8"	28'-1"	25'-6"	23'-4"	19'-8"
	NI-80	28'-2"	26'-0"	24'-9"	21'-11"	30'-0"	27'-10"	26'-7"	21'-11"
	NI-90	28'-8"	26'-6"	25'-2"	21'-11"	30'-7"	28'-4"	27'-0"	21'-11"

Notes :

1. Les portées libres indiquées sont basées sur la norme CSA O86-14 et le CNB 2015 et s'appliquent à la construction de planchers résidentiels respectant les critères de conception ci-dessus.
2. Pour les portées multiples, les portées extérieures doivent être supérieures à 40% de la portée adjacente.
3. La longueur d'appui minimale est de 1-3/4 pouce pour les appuis d'extrémités et de 3-1/2 pouces pour les appuis intermédiaires.
4. Les raidisseurs d'appui ne sont pas requis lorsque les solives sont utilisées conformément à ce tableau, sauf si requis pour les étriers.

Portées maximales de plancher – H5.1, blocage à mi-portée

Critères de conception

Portées :	Portée simple
Charges :	Surcharge = 40 lbf/pi ² et charge permanente = 35 lbf/pi ²
Limite de flèche :	L/240 sous la charge totale
Revêtement :	Panneaux de copeaux orientés (OSB) 7/8 po, cloué et collé

Portées maximales de plancher

Limite de flèche de L/480 sous la surcharge

Hauteur	Série	Solive seule				Blocage à mi-portée			
		Espacement centre/centre				Espacement centre/centre			
		12"	16"	19,2"	24"	12"	16"	19,2"	24"
9-1/2"	NI-20	16'-8"	15'-5"	14'-3"	12'-9"	17'-0"	15'-5"	14'-3"	12'-9"
	NI-40x	17'-9"	16'-7"	15'-1"	13'-6"	18'-6"	16'-7"	15'-1"	13'-6"
	NI-60	17'-11"	16'-11"	16'-3"	15'-6"	18'-9"	17'-7"	16'-8"	15'-6"
	NI-80	19'-3"	17'-10"	17'-2"	16'-5"	20'-1"	18'-8"	17'-10"	17'-0"
11-7/8"	NI-20	18'-11"	17'-8"	16'-3"	14'-6"	19'-11"	17'-10"	16'-3"	14'-6"
	NI-40x	20'-5"	18'-10"	17'-3"	15'-5"	21'-6"	18'-10"	17'-3"	15'-5"
	NI-60	20'-8"	19'-3"	18'-4"	17'-5"	21'-9"	20'-4"	19'-4"	17'-8"
	NI-80	22'-2"	20'-7"	19'-7"	18'-5"	23'-3"	21'-8"	20'-8"	19'-6"
	NI-90	22'-8"	21'-0"	19'-11"	18'-9"	23'-9"	22'-1"	21'-1"	19'-10"
14"	NI-40x	22'-7"	20'-9"	18'-11"	16'-11"	23'-11"	20'-9"	18'-11"	16'-11"
	NI-60	23'-0"	21'-4"	20'-4"	19'-2"	24'-3"	22'-8"	21'-7"	19'-5"
	NI-80	24'-8"	22'-10"	21'-8"	20'-5"	26'-0"	24'-2"	23'-0"	21'-9"
	NI-90	25'-2"	23'-3"	22'-1"	20'-10"	26'-6"	24'-7"	23'-5"	22'-0"
16"	NI-60	25'-1"	23'-3"	22'-1"	20'-10"	26'-7"	24'-9"	23'-4"	20'-11"
	NI-80	26'-10"	24'-10"	23'-7"	22'-3"	28'-5"	26'-5"	25'-2"	23'-6"
	NI-90	27'-4"	25'-4"	24'-1"	22'-7"	28'-11"	26'-11"	25'-7"	23'-6"

Limite de flèche de L/360 sous la surcharge

Hauteur	Série	Solive seule				Blocage à mi-portée			
		Espacement centre/centre				Espacement centre/centre			
		12"	16"	19,2"	24"	12"	16"	19,2"	24"
9-1/2"	NI-20	16'-8"	15'-5"	14'-3"	12'-9"	17'-1"	15'-5"	14'-3"	12'-9"
	NI-40x	17'-9"	16'-7"	15'-1"	13'-6"	18'-6"	16'-7"	15'-1"	13'-6"
	NI-60	17'-11"	16'-11"	16'-3"	15'-6"	18'-9"	17'-7"	16'-10"	15'-6"
	NI-80	19'-3"	17'-10"	17'-2"	16'-5"	20'-1"	18'-8"	17'-10"	17'-1"
11-7/8"	NI-20	18'-11"	17'-8"	16'-3"	14'-6"	19'-11"	17'-10"	16'-3"	14'-6"
	NI-40x	20'-5"	18'-10"	17'-3"	15'-5"	21'-6"	18'-10"	17'-3"	15'-5"
	NI-60	20'-8"	19'-3"	18'-4"	17'-5"	21'-9"	20'-4"	19'-4"	17'-8"
	NI-80	22'-2"	20'-7"	19'-7"	18'-5"	23'-3"	21'-8"	20'-8"	19'-6"
	NI-90	22'-8"	21'-0"	19'-11"	18'-9"	23'-9"	22'-1"	21'-1"	19'-10"
14"	NI-40x	22'-7"	20'-9"	18'-11"	16'-11"	23'-11"	20'-9"	18'-11"	16'-11"
	NI-60	23'-0"	21'-4"	20'-4"	19'-2"	24'-3"	22'-8"	21'-7"	19'-5"
	NI-80	24'-8"	22'-10"	21'-8"	20'-5"	26'-0"	24'-2"	23'-0"	21'-9"
	NI-90	25'-2"	23'-3"	22'-1"	20'-10"	26'-6"	24'-7"	23'-5"	22'-0"
16"	NI-60	25'-1"	23'-3"	22'-1"	20'-10"	26'-7"	24'-9"	23'-4"	20'-11"
	NI-80	26'-10"	24'-10"	23'-7"	22'-3"	28'-5"	26'-5"	25'-2"	23'-6"
	NI-90	27'-4"	25'-4"	24'-1"	22'-7"	28'-11"	26'-11"	25'-7"	23'-6"

Notes :

1. Les portées libres indiquées sur la norme CSA O86-14 et le CNB 2015 et s'appliquent à la construction de planchers résidentiels respectant les critères de conception ci-dessus.
2. Pour les portées multiples, les portées extérieures doivent être supérieures à 40% de la portée adjacente.
3. La longueur d'appui minimale est de 1-3/4 pouce pour les appuis d'extrémités et de 3-1/2 pouces pour les appuis intermédiaires.
4. Les raidisseurs d'appui ne sont pas requis lorsque les solives sont utilisées conformément à ce tableau, sauf si requis pour les étriers.

Portées maximales de plancher – H5.2, blocage à mi-portée

Critères de conception

Portées :	Portées multiples
Charges :	Surcharge = 40 lbf/pi ² et charge permanente = 35 lbf/pi ²
Limite de flèche :	L/240 sous la charge totale
Revêtement :	Panneaux de copeaux orientés (OSB) 7/8 po, cloué et collé

Portées maximales de plancher

Limite de flèche de L/480 sous la surcharge

Hauteur	Série	Solive seule				Blocage à mi-portée			
		Espacement centre/centre				Espacement centre/centre			
		12"	16"	19,2"	24"	12"	16"	19,2"	24"
9-1/2"	NI-20	17'-11"	15'-7"	14'-2"	12'-8"	18'-0"	15'-7"	14'-2"	12'-8"
	NI-40x	19'-1"	16'-6"	15'-0"	13'-5"	19'-1"	16'-6"	15'-0"	13'-5"
	NI-60	19'-9"	18'-4"	17'-3"	14'-4"	20'-6"	18'-11"	17'-3"	14'-4"
	NI-80	21'-3"	19'-8"	18'-0"	14'-4"	22'-0"	20'-6"	18'-0"	14'-4"
11-7/8"	NI-20	20'-6"	17'-9"	16'-2"	14'-5"	20'-6"	17'-9"	16'-2"	14'-5"
	NI-40x	21'-9"	18'-10"	17'-2"	15'-4"	21'-9"	18'-10"	17'-2"	15'-4"
	NI-60	22'-10"	21'-2"	19'-8"	17'-7"	23'-10"	21'-7"	19'-8"	17'-7"
	NI-80	24'-6"	22'-8"	21'-7"	17'-10"	25'-7"	23'-10"	22'-4"	17'-10"
	NI-90	25'-0"	23'-2"	22'-0"	20'-3"	26'-1"	24'-3"	23'-2"	20'-3"
14"	NI-40x	23'-11"	20'-8"	18'-10"	16'-10"	23'-11"	20'-8"	18'-10"	16'-10"
	NI-60	25'-4"	23'-6"	21'-7"	18'-11"	26'-8"	23'-8"	21'-7"	18'-11"
	NI-80	27'-2"	25'-2"	24'-0"	20'-1"	28'-6"	26'-7"	25'-2"	20'-1"
	NI-90	27'-9"	25'-8"	24'-5"	20'-3"	29'-1"	27'-1"	25'-4"	20'-3"
16"	NI-60	27'-7"	25'-6"	23'-4"	19'-8"	29'-2"	25'-6"	23'-4"	19'-8"
	NI-80	29'-7"	27'-5"	26'-1"	21'-11"	31'-2"	29'-0"	27'-6"	21'-11"
	NI-90	30'-2"	27'-11"	26'-7"	21'-11"	31'-9"	29'-7"	27'-6"	21'-11"

Limite de flèche de L/360 sous la surcharge

Hauteur	Série	Solive seule				Blocage à mi-portée			
		Espacement centre/centre				Espacement centre/centre			
		12"	16"	19,2"	24"	12"	16"	19,2"	24"
9-1/2"	NI-20	17'-11"	15'-7"	14'-2"	12'-8"	18'-0"	15'-7"	14'-2"	12'-8"
	NI-40x	19'-1"	16'-6"	15'-0"	13'-5"	19'-1"	16'-6"	15'-0"	13'-5"
	NI-60	19'-9"	18'-4"	17'-3"	14'-4"	20'-6"	18'-11"	17'-3"	14'-4"
	NI-80	21'-3"	19'-8"	18'-0"	14'-4"	22'-0"	20'-6"	18'-0"	14'-4"
11-7/8"	NI-20	20'-6"	17'-9"	16'-2"	14'-5"	20'-6"	17'-9"	16'-2"	14'-5"
	NI-40x	21'-9"	18'-10"	17'-2"	15'-4"	21'-9"	18'-10"	17'-2"	15'-4"
	NI-60	22'-10"	21'-2"	19'-8"	17'-7"	23'-10"	21'-7"	19'-8"	17'-7"
	NI-80	24'-6"	22'-8"	21'-7"	17'-10"	25'-7"	23'-10"	22'-4"	17'-10"
	NI-90	25'-0"	23'-2"	22'-0"	20'-3"	26'-1"	24'-3"	23'-2"	20'-3"
14"	NI-40x	23'-11"	20'-8"	18'-10"	16'-10"	23'-11"	20'-8"	18'-10"	16'-10"
	NI-60	25'-4"	23'-6"	21'-7"	18'-11"	26'-8"	23'-8"	21'-7"	18'-11"
	NI-80	27'-2"	25'-2"	24'-0"	20'-1"	28'-6"	26'-7"	25'-2"	20'-1"
	NI-90	27'-9"	25'-8"	24'-5"	20'-3"	29'-1"	27'-1"	25'-4"	20'-3"
16"	NI-60	27'-7"	25'-6"	23'-4"	19'-8"	29'-2"	25'-6"	23'-4"	19'-8"
	NI-80	29'-7"	27'-5"	26'-1"	21'-11"	31'-2"	29'-0"	27'-6"	21'-11"
	NI-90	30'-2"	27'-11"	26'-7"	21'-11"	31'-9"	29'-7"	27'-6"	21'-11"

Notes :

1. Les portées libres indiquées sont basées sur la norme CSA O86-14 et le CNB 2015 et s'appliquent à la construction de planchers résidentiels respectant les critères de conception ci-dessus.
2. Pour les portées multiples, les portées extérieures doivent être supérieures à 40% de la portée adjacente.
3. La longueur d'appui minimale est de 1-3/4 pouce pour les appuis d'extrémités et de 3-1/2 pouces pour les appuis intermédiaires.
4. Les raidisseurs d'appui ne sont pas requis lorsque les solives sont utilisées conformément à ce tableau, sauf si requis pour les étriers.

Portées maximales de plancher – H6.1, blocage à mi-portée

Critères de conception

Portées :	Portée simple
Charges :	Surcharge = 40 lbf/pi ² et charge permanente = 35 lbf/pi ²
Limite de flèche :	L/240 sous la charge totale
Revêtement :	Contreplaqué de résineux canadiens 5/8 po, cloué et collé

Portées maximales de plancher

Limite de flèche de L/480 sous la surcharge

Hauteur	Série	Solive seule				Blocage à mi-portée			
		Espacement centre/centre				Espacement centre/centre			
		12"	16"	19,2"	24"	12"	16"	19,2"	24"
9-1/2"	NI-20	14'-11"	14'-1"	13'-7"	-	15'-10"	15'-0"	14'-3"	-
	NI-40x	15'-11"	15'-0"	14'-6"	-	16'-11"	16'-0"	15'-1"	-
	NI-60	16'-1"	15'-2"	14'-8"	-	17'-1"	16'-1"	15'-7"	-
	NI-80	17'-1"	16'-1"	15'-6"	-	18'-1"	17'-0"	16'-5"	-
11-7/8"	NI-20	16'-9"	15'-10"	15'-4"	-	17'-11"	17'-0"	16'-3"	-
	NI-40x	17'-10"	16'-10"	16'-3"	-	19'-5"	18'-0"	17'-3"	-
	NI-60	18'-1"	17'-0"	16'-5"	-	19'-8"	18'-3"	17'-7"	-
	NI-80	19'-6"	18'-0"	17'-4"	-	21'-1"	19'-6"	18'-8"	-
	NI-90	19'-11"	18'-4"	17'-8"	-	21'-6"	19'-11"	19'-0"	-
14"	NI-40x	19'-10"	18'-4"	17'-8"	-	21'-8"	20'-1"	18'-11"	-
	NI-60	20'-2"	18'-8"	17'-11"	-	22'-0"	20'-5"	19'-7"	-
	NI-80	21'-8"	20'-0"	19'-1"	-	23'-7"	21'-10"	20'-11"	-
	NI-90	22'-1"	20'-5"	19'-6"	-	24'-1"	22'-3"	21'-3"	-
16"	NI-60	22'-0"	20'-4"	19'-6"	-	24'-2"	22'-5"	21'-5"	-
	NI-80	23'-7"	21'-10"	20'-10"	-	25'-10"	23'-11"	22'-10"	-
	NI-90	24'-1"	22'-2"	21'-2"	-	26'-4"	24'-4"	23'-3"	-

Limite de flèche de L/360 sous la surcharge

Hauteur	Série	Solive seule				Blocage à mi-portée			
		Espacement centre/centre				Espacement centre/centre			
		12"	16"	19,2"	24"	12"	16"	19,2"	24"
9-1/2"	NI-20	14'-11"	14'-1"	13'-7"	-	15'-10"	15'-0"	14'-3"	-
	NI-40x	15'-11"	15'-0"	14'-6"	-	16'-11"	16'-0"	15'-1"	-
	NI-60	16'-1"	15'-2"	14'-8"	-	17'-1"	16'-1"	15'-7"	-
	NI-80	17'-1"	16'-1"	15'-6"	-	18'-1"	17'-0"	16'-5"	-
11-7/8"	NI-20	16'-9"	15'-10"	15'-4"	-	17'-11"	17'-0"	16'-3"	-
	NI-40x	17'-10"	16'-10"	16'-3"	-	19'-5"	18'-0"	17'-3"	-
	NI-60	18'-1"	17'-0"	16'-5"	-	19'-8"	18'-3"	17'-7"	-
	NI-80	19'-6"	18'-0"	17'-4"	-	21'-1"	19'-6"	18'-8"	-
	NI-90	19'-11"	18'-4"	17'-8"	-	21'-6"	19'-11"	19'-0"	-
14"	NI-40x	19'-10"	18'-4"	17'-8"	-	21'-8"	20'-1"	18'-11"	-
	NI-60	20'-2"	18'-8"	17'-11"	-	22'-0"	20'-5"	19'-7"	-
	NI-80	21'-8"	20'-0"	19'-1"	-	23'-7"	21'-10"	20'-11"	-
	NI-90	22'-1"	20'-5"	19'-6"	-	24'-1"	22'-3"	21'-3"	-
16"	NI-60	22'-0"	20'-4"	19'-6"	-	24'-2"	22'-5"	21'-5"	-
	NI-80	23'-7"	21'-10"	20'-10"	-	25'-10"	23'-11"	22'-10"	-
	NI-90	24'-1"	22'-2"	21'-2"	-	26'-4"	24'-4"	23'-3"	-

Notes :

1. Les portées libres indiquées sur la norme CSA O86-14 et le CNB 2015 et s'appliquent à la construction de planchers résidentiels respectant les critères de conception ci-dessus.
2. Pour les portées multiples, les portées extérieures doivent être supérieures à 40% de la portée adjacente.
3. La longueur d'appui minimale est de 1-3/4 pouce pour les appuis d'extrémités et de 3-1/2 pouces pour les appuis intermédiaires.
4. Les raidisseurs d'appui ne sont pas requis lorsque les solives sont utilisées conformément à ce tableau, sauf si requis pour les étriers.

Portées maximales de plancher – H6.2, blocage à mi-portée

Critères de conception

Portées :	Portées multiples
Charges :	Surcharge = 40 lbf/pi ² et charge permanente = 35 lbf/pi ²
Limite de flèche :	L/240 sous la charge totale
Revêtement :	Contreplaqué de résineux canadiens 5/8 po, cloué et collé

Portées maximales de plancher

Limite de flèche de L/480 sous la surcharge

Hauteur	Série	Solive seule				Blocage à mi-portée			
		Espacement centre/centre				Espacement centre/centre			
		12"	16"	19,2"	24"	12"	16"	19,2"	24"
9-1/2"	NI-20	16'-0"	15'-2"	14'-2"	-	17'-0"	15'-7"	14'-2"	-
	NI-40x	17'-2"	16'-2"	15'-0"	-	18'-2"	16'-6"	15'-0"	-
	NI-60	17'-4"	16'-4"	15'-10"	-	18'-5"	17'-4"	16'-9"	-
	NI-80	18'-7"	17'-4"	16'-9"	-	19'-10"	18'-5"	17'-8"	-
11-7/8"	NI-20	18'-1"	17'-1"	16'-2"	-	19'-7"	17'-9"	16'-2"	-
	NI-40x	19'-8"	18'-3"	17'-2"	-	21'-3"	18'-10"	17'-2"	-
	NI-60	20'-0"	18'-6"	17'-9"	-	21'-7"	20'-0"	19'-2"	-
	NI-80	21'-6"	19'-11"	19'-0"	-	23'-1"	21'-5"	20'-6"	-
14"	NI-90	22'-0"	20'-4"	19'-5"	-	23'-7"	21'-10"	20'-11"	-
	NI-40x	21'-10"	20'-3"	18'-10"	-	23'-9"	20'-8"	18'-10"	-
	NI-60	22'-3"	20'-7"	19'-9"	-	24'-2"	22'-5"	21'-6"	-
	NI-80	23'-11"	22'-1"	21'-1"	-	25'-11"	24'-0"	22'-11"	-
16"	NI-90	24'-5"	22'-7"	21'-6"	-	26'-5"	24'-5"	23'-4"	-
	NI-60	24'-3"	22'-6"	21'-6"	-	26'-6"	24'-7"	23'-4"	-
	NI-80	26'-1"	24'-1"	23'-0"	-	28'-4"	26'-3"	25'-1"	-
	NI-90	26'-7"	24'-7"	23'-5"	-	28'-11"	26'-9"	25'-7"	-

Limite de flèche de L/360 sous la surcharge

Hauteur	Série	Solive seule				Blocage à mi-portée			
		Espacement centre/centre				Espacement centre/centre			
		12"	16"	19,2"	24"	12"	16"	19,2"	24"
9-1/2"	NI-20	16'-0"	15'-2"	14'-2"	-	17'-0"	15'-7"	14'-2"	-
	NI-40x	17'-2"	16'-2"	15'-0"	-	18'-2"	16'-6"	15'-0"	-
	NI-60	17'-4"	16'-4"	15'-10"	-	18'-5"	17'-4"	16'-9"	-
	NI-80	18'-7"	17'-4"	16'-9"	-	19'-10"	18'-5"	17'-8"	-
11-7/8"	NI-20	18'-1"	17'-1"	16'-2"	-	19'-7"	17'-9"	16'-2"	-
	NI-40x	19'-8"	18'-3"	17'-2"	-	21'-3"	18'-10"	17'-2"	-
	NI-60	20'-0"	18'-6"	17'-9"	-	21'-7"	20'-0"	19'-2"	-
	NI-80	21'-6"	19'-11"	19'-0"	-	23'-1"	21'-5"	20'-6"	-
14"	NI-90	22'-0"	20'-4"	19'-5"	-	23'-7"	21'-10"	20'-11"	-
	NI-40x	21'-10"	20'-3"	18'-10"	-	23'-9"	20'-8"	18'-10"	-
	NI-60	22'-3"	20'-7"	19'-9"	-	24'-2"	22'-5"	21'-6"	-
	NI-80	23'-11"	22'-1"	21'-1"	-	25'-11"	24'-0"	22'-11"	-
16"	NI-90	24'-5"	22'-7"	21'-6"	-	26'-5"	24'-5"	23'-4"	-
	NI-60	24'-3"	22'-6"	21'-6"	-	26'-6"	24'-7"	23'-4"	-
	NI-80	26'-1"	24'-1"	23'-0"	-	28'-4"	26'-3"	25'-1"	-
	NI-90	26'-7"	24'-7"	23'-5"	-	28'-11"	26'-9"	25'-7"	-

Notes :

1. Les portées libres indiquées sont basées sur la norme CSA O86-14 et le CNB 2015 et s'appliquent à la construction de planchers résidentiels respectant les critères de conception ci-dessus.
2. Pour les portées multiples, les portées extérieures doivent être supérieures à 40% de la portée adjacente.
3. La longueur d'appui minimale est de 1-3/4 pouce pour les appuis d'extrémités et de 3-1/2 pouces pour les appuis intermédiaires.
4. Les raidisseurs d'appui ne sont pas requis lorsque les solives sont utilisées conformément à ce tableau, sauf si requis pour les étriers.

Portées maximales de plancher – H7.1, blocage à mi-portée

Critères de conception

Portées :	Portée simple
Charges :	Surcharge = 40 lbf/pi ² et charge permanente = 35 lbf/pi ²
Limite de flèche :	L/240 sous la charge totale
Revêtement :	Contreplaqué de résineux canadiens 3/4 po, cloué et collé

Portées maximales de plancher

Limite de flèche de L/480 sous la surcharge

Hauteur	Série	Solive seule				Blocage à mi-portée			
		Espacement centre/centre				Espacement centre/centre			
		12"	16"	19,2"	24"	12"	16"	19,2"	24"
9-1/2"	NI-20	15'-10"	15'-0"	14'-3"	12'-9"	16'-8"	15'-5"	14'-3"	12'-9"
	NI-40x	16'-11"	15'-11"	15'-1"	13'-6"	17'-8"	16'-7"	15'-1"	13'-6"
	NI-60	17'-1"	16'-1"	15'-6"	14'-10"	17'-10"	16'-11"	16'-4"	15'-5"
	NI-80	18'-1"	17'-0"	16'-4"	15'-8"	19'-2"	17'-10"	17'-2"	16'-6"
11-7/8"	NI-20	17'-10"	16'-10"	16'-2"	14'-6"	19'-0"	17'-9"	16'-3"	14'-6"
	NI-40x	19'-3"	17'-10"	17'-2"	15'-5"	20'-6"	18'-10"	17'-3"	15'-5"
	NI-60	19'-6"	18'-1"	17'-4"	16'-8"	20'-9"	19'-4"	18'-6"	17'-8"
	NI-80	20'-11"	19'-4"	18'-5"	17'-7"	22'-3"	20'-8"	19'-8"	18'-8"
	NI-90	21'-4"	19'-9"	18'-9"	17'-10"	22'-8"	21'-1"	20'-1"	19'-0"
14"	NI-40x	21'-4"	19'-9"	18'-10"	16'-11"	22'-10"	20'-9"	18'-11"	16'-11"
	NI-60	21'-8"	20'-1"	19'-2"	18'-2"	23'-3"	21'-7"	20'-7"	19'-5"
	NI-80	23'-3"	21'-6"	20'-5"	19'-4"	24'-10"	23'-1"	22'-0"	20'-10"
	NI-90	23'-9"	21'-11"	20'-10"	19'-8"	25'-4"	23'-6"	22'-5"	21'-2"
16"	NI-60	23'-7"	21'-10"	20'-10"	19'-9"	25'-5"	23'-8"	22'-7"	20'-11"
	NI-80	25'-4"	23'-5"	22'-3"	21'-1"	27'-2"	25'-3"	24'-1"	22'-9"
	NI-90	25'-10"	23'-10"	22'-8"	21'-5"	27'-8"	25'-8"	24'-6"	23'-2"

Limite de flèche de L/360 sous la surcharge

Hauteur	Série	Solive seule				Blocage à mi-portée			
		Espacement centre/centre				Espacement centre/centre			
		12"	16"	19,2"	24"	12"	16"	19,2"	24"
9-1/2"	NI-20	15'-10"	15'-0"	14'-3"	12'-9"	16'-8"	15'-5"	14'-3"	12'-9"
	NI-40x	16'-11"	15'-11"	15'-1"	13'-6"	17'-8"	16'-7"	15'-1"	13'-6"
	NI-60	17'-1"	16'-1"	15'-6"	14'-10"	17'-10"	16'-11"	16'-4"	15'-6"
	NI-80	18'-1"	17'-0"	16'-4"	15'-8"	19'-2"	17'-10"	17'-2"	16'-6"
11-7/8"	NI-20	17'-10"	16'-10"	16'-2"	14'-6"	19'-0"	17'-9"	16'-3"	14'-6"
	NI-40x	19'-3"	17'-10"	17'-2"	15'-5"	20'-6"	18'-10"	17'-3"	15'-5"
	NI-60	19'-6"	18'-1"	17'-4"	16'-8"	20'-9"	19'-4"	18'-6"	17'-8"
	NI-80	20'-11"	19'-4"	18'-5"	17'-7"	22'-3"	20'-8"	19'-8"	18'-8"
	NI-90	21'-4"	19'-9"	18'-9"	17'-10"	22'-8"	21'-1"	20'-1"	19'-0"
14"	NI-40x	21'-4"	19'-9"	18'-10"	16'-11"	22'-10"	20'-9"	18'-11"	16'-11"
	NI-60	21'-8"	20'-1"	19'-2"	18'-2"	23'-3"	21'-7"	20'-7"	19'-5"
	NI-80	23'-3"	21'-6"	20'-5"	19'-4"	24'-10"	23'-1"	22'-0"	20'-10"
	NI-90	23'-9"	21'-11"	20'-10"	19'-8"	25'-4"	23'-6"	22'-5"	21'-2"
16"	NI-60	23'-7"	21'-10"	20'-10"	19'-9"	25'-5"	23'-8"	22'-7"	20'-11"
	NI-80	25'-4"	23'-5"	22'-3"	21'-1"	27'-2"	25'-3"	24'-1"	22'-9"
	NI-90	25'-10"	23'-10"	22'-8"	21'-5"	27'-8"	25'-8"	24'-6"	23'-2"

Notes :

1. Les portées libres indiquées sur la norme CSA O86-14 et le CNB 2015 et s'appliquent à la construction de planchers résidentiels respectant les critères de conception ci-dessus.
2. Pour les portées multiples, les portées extérieures doivent être supérieures à 40% de la portée adjacente.
3. La longueur d'appui minimale est de 1-3/4 pouce pour les appuis d'extrémités et de 3-1/2 pouces pour les appuis intermédiaires.
4. Les raidisseurs d'appui ne sont pas requis lorsque les solives sont utilisées conformément à ce tableau, sauf si requis pour les étriers.

Portées maximales de plancher – H7.2, blocage à mi-portée

Critères de conception

Portées :	Portées multiples
Charges :	Surcharge = 40 lbf/pi ² et charge permanente = 35 lbf/pi ²
Limite de flèche :	L/240 sous la charge totale
Revêtement :	Contreplaqué de résineux canadiens 3/4 po, cloué et collé

Portées maximales de plancher

Limite de flèche de L/480 sous la surcharge

Hauteur	Série	Solive seule				Blocage à mi-portée			
		Espacement centre/centre				Espacement centre/centre			
		12"	16"	19,2"	24"	12"	16"	19,2"	24"
9-1/2"	NI-20	17'-1"	15'-7"	14'-2"	12'-8"	17'-10"	15'-7"	14'-2"	12'-8"
	NI-40x	18'-4"	16'-6"	15'-0"	13'-5"	19'-1"	16'-6"	15'-0"	13'-5"
	NI-60	18'-7"	17'-4"	16'-9"	14'-4"	19'-7"	18'-2"	17'-3"	14'-4"
	NI-80	20'-0"	18'-6"	17'-8"	14'-4"	21'-0"	19'-6"	18'-0"	14'-4"
11-7/8"	NI-20	19'-7"	17'-9"	16'-2"	14'-5"	20'-6"	17'-9"	16'-2"	14'-5"
	NI-40x	21'-2"	18'-10"	17'-2"	15'-4"	21'-9"	18'-10"	17'-2"	15'-4"
	NI-60	21'-6"	19'-11"	19'-0"	17'-7"	22'-10"	21'-2"	19'-8"	17'-7"
	NI-80	23'-1"	21'-4"	20'-4"	17'-10"	24'-5"	22'-8"	21'-7"	17'-10"
	NI-90	23'-7"	21'-9"	20'-9"	19'-8"	24'-11"	23'-1"	22'-1"	20'-3"
14"	NI-40x	23'-6"	20'-8"	18'-10"	16'-10"	23'-11"	20'-8"	18'-10"	16'-10"
	NI-60	23'-11"	22'-2"	21'-1"	18'-11"	25'-6"	23'-8"	21'-7"	18'-11"
	NI-80	25'-8"	23'-9"	22'-7"	20'-1"	27'-3"	25'-4"	24'-2"	20'-1"
	NI-90	26'-2"	24'-2"	23'-0"	20'-3"	27'-10"	25'-10"	24'-7"	20'-3"
16"	NI-60	26'-1"	24'-1"	23'-0"	19'-8"	27'-11"	25'-6"	23'-4"	19'-8"
	NI-80	27'-11"	25'-10"	24'-7"	21'-11"	29'-10"	27'-9"	26'-5"	21'-11"
	NI-90	28'-6"	26'-4"	25'-0"	21'-11"	30'-5"	28'-3"	26'-11"	21'-11"

Limite de flèche de L/360 sous la surcharge

Hauteur	Série	Solive seule				Blocage à mi-portée			
		Espacement centre/centre				Espacement centre/centre			
		12"	16"	19,2"	24"	12"	16"	19,2"	24"
9-1/2"	NI-20	17'-1"	15'-7"	14'-2"	12'-8"	17'-10"	15'-7"	14'-2"	12'-8"
	NI-40x	18'-4"	16'-6"	15'-0"	13'-5"	19'-1"	16'-6"	15'-0"	13'-5"
	NI-60	18'-7"	17'-4"	16'-9"	14'-4"	19'-7"	18'-2"	17'-3"	14'-4"
	NI-80	20'-0"	18'-6"	17'-8"	14'-4"	21'-0"	19'-6"	18'-0"	14'-4"
11-7/8"	NI-20	19'-7"	17'-9"	16'-2"	14'-5"	20'-6"	17'-9"	16'-2"	14'-5"
	NI-40x	21'-2"	18'-10"	17'-2"	15'-4"	21'-9"	18'-10"	17'-2"	15'-4"
	NI-60	21'-6"	19'-11"	19'-0"	17'-7"	22'-10"	21'-2"	19'-8"	17'-7"
	NI-80	23'-1"	21'-4"	20'-4"	17'-10"	24'-5"	22'-8"	21'-7"	17'-10"
	NI-90	23'-7"	21'-9"	20'-9"	19'-8"	24'-11"	23'-1"	22'-1"	20'-3"
14"	NI-40x	23'-6"	20'-8"	18'-10"	16'-10"	23'-11"	20'-8"	18'-10"	16'-10"
	NI-60	23'-11"	22'-2"	21'-1"	18'-11"	25'-6"	23'-8"	21'-7"	18'-11"
	NI-80	25'-8"	23'-9"	22'-7"	20'-1"	27'-3"	25'-4"	24'-2"	20'-1"
	NI-90	26'-2"	24'-2"	23'-0"	20'-3"	27'-10"	25'-10"	24'-7"	20'-3"
16"	NI-60	26'-1"	24'-1"	23'-0"	19'-8"	27'-11"	25'-6"	23'-4"	19'-8"
	NI-80	27'-11"	25'-10"	24'-7"	21'-11"	29'-10"	27'-9"	26'-5"	21'-11"
	NI-90	28'-6"	26'-4"	25'-0"	21'-11"	30'-5"	28'-3"	26'-11"	21'-11"

Notes :

1. Les portées libres indiquées sont basées sur la norme CSA O86-14 et le CNB 2015 et s'appliquent à la construction de planchers résidentiels respectant les critères de conception ci-dessus.
2. Pour les portées multiples, les portées extérieures doivent être supérieures à 40% de la portée adjacente.
3. La longueur d'appui minimale est de 1-3/4 pouce pour les appuis d'extrémités et de 3-1/2 pouces pour les appuis intermédiaires.
4. Les raidisseurs d'appui ne sont pas requis lorsque les solives sont utilisées conformément à ce tableau, sauf si requis pour les étriers.