

Fire Protection of Floors, FP-Nordic-01

The purpose of this technical note is to provide a solution for fire protection of floors for compliance with the International Residential Code (IRC). The following fire resistance design is an alternative to the 2-by-10 dimensional lumber prescribed in 2012 IRC Section R501.3 and 2015/2018 IRC Section R302.13 Exception 4, with demonstrated equivalent fire performance.

This technical note only applies to:

- NI-40x (depths of 9-1/2, 11-7/8 and 14 inches), NI-60 (depths of 9-1/2, 11-7/8, 14 and 16 inches) and NI-80 (depths of 9-1/2, 11-7/8, 14 and 16 inches) I-joists.
References: APA Product Report PR-S274 and ICC-ES Evaluation Report ESR-1742

Installation requirements:

- Floor sheathing: Materials and installation in accordance with 2012, 2015, and 2018 IRC Section R503.
- I-joist: Installation in accordance with the Nordic Joist Installation Guide (www.nordic.ca). Maximum 24 inches on center spacing. At each hole location, the 7/16 inch or thicker wood structural panels shall be cut with the web hole on both sides of the I-joist to allow the passage of a wire, pipe, or duct, in accordance with the web hole requirements permitted in the installation guide.
- Wood structural panel (WSP) for web protection: Minimum 7/16 inch Performance Category in compliance with DOC PS 1 or PS 2. The WSP shall continuously cover the entire length of the I-joist web on both sides, including at bearing and cantilever, and for I-joist blocking panels. The panel-to-panel joints shall be tight with a joint gap of 1/16 inch (1.6 mm) or less and not required to be finished with tape or joint compound. Fasteners: Each WSP shall be fastened with 2 rows of 1/2 inch x 1 inch (12.7 mm x 25.4 mm) 16-gauge construction staples at 9 inches (229 mm) on center and 1 inch (25.4 mm) from the flange edge. Fasteners may be staggered from top to bottom. At hole location, fasteners shall be installed 1 inch (25.4 mm) from the edge of the hole, top and bottom. An adhesive may be used in addition to the construction staples.
- When required, backer blocks and web stiffeners shall be installed per the details provided on page 3.

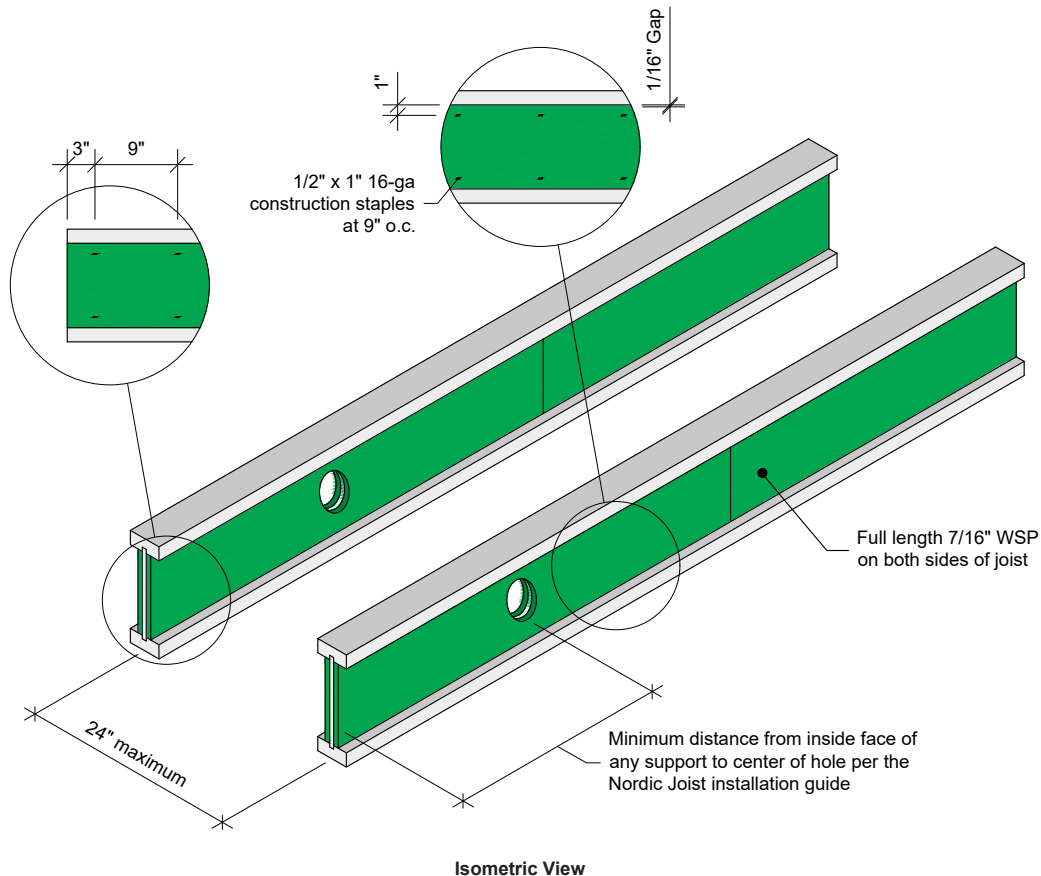

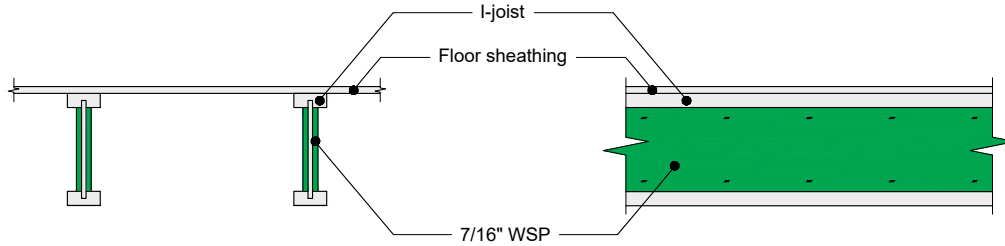

Wood Structural Panel for Web Protection

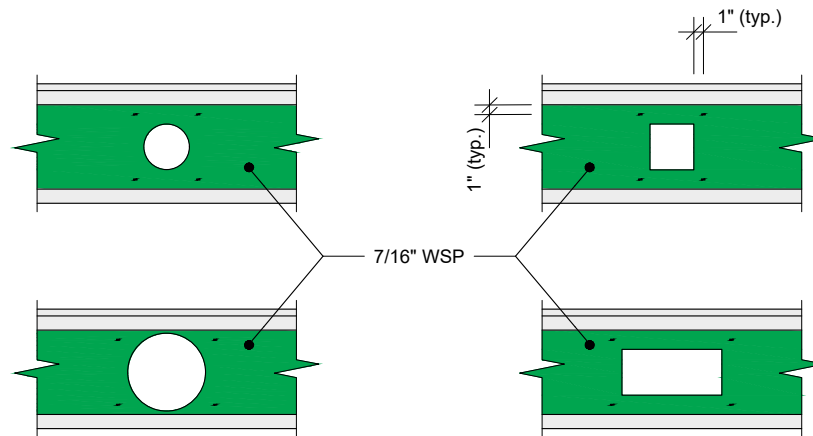

Installation Requirements at Web Holes

Notes:

- (a) In accordance with Exception 3 of 2012 IRC Section R501.3 and 2015/2018 IRC Section R302.13, portions of floor assembly can be unprotected when complying with the following:
 - 1) The aggregate area of the unprotected portions shall not exceed 80 square feet.
 - 2) Fire blocking in accordance with 2012, 2015, and 2018 IRC Section R302.11.1 shall be installed along the perimeter of the unprotected portion to separate the unprotected portion from the remainder of the floor assembly.
- (b) Insulation may be required for energy code compliance purposes. Check with the local building official for specific jurisdictional requirements.
- (c) Penetrations or openings for ducts, vents, electrical outlets, lighting, devices, luminaires, wires, speakers, drainage, piping and similar openings or penetrations shall be permitted.

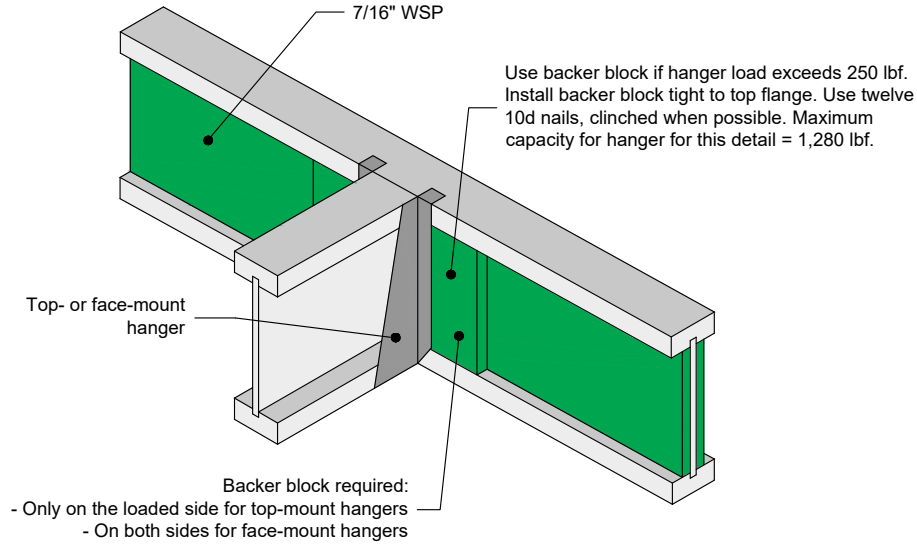

Installation of Backer Blocks
(Detail 1h – modified)

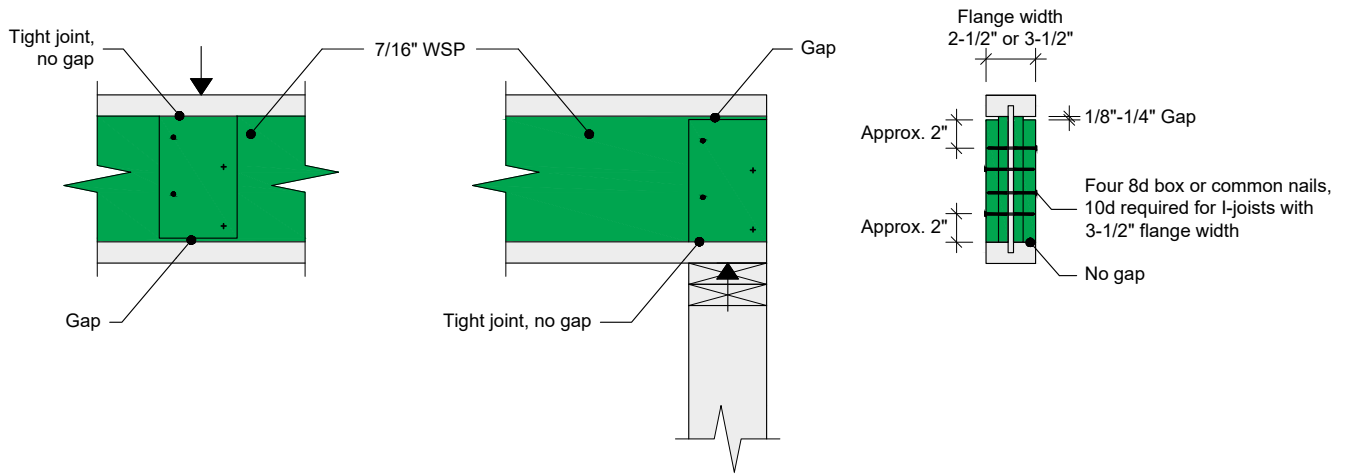

Concentrated Load
(Load Stiffener)

End Bearing
(Bearing Stiffener)

Installation of Web Stiffeners
(Detail 2 – modified)