

Hybrid Structures – Wood-Steel Coordination Standard Operating Procedure

This technical note addresses interfaces (connections) between wood members and steel members within hybrid wood–steel structural systems. This note outlines several examples of wood–steel hybrid connections and highlights best practices for coordination - from design to erection - as well as stakeholders' responsibilities.

Wood–steel interfaces not covered in this document (such as miscellaneous metals, curtain wall systems, canopies, anchors), as well as wood–concrete interfaces, are outside the scope of this technical note.

Hybrid Structures

Hybrid wood–steel structures are common. Various configuration types carried out by Nordic Structures are presented in Table 1:

Table 1 – Configuration Types

Structure entirely made of steel, except for the floors and roof, made of cross-laminated timber

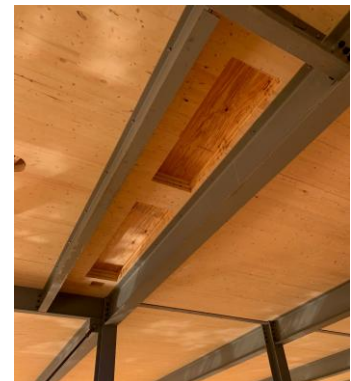

Structure entirely made of wood, except for the bracings, made of steel (conventional steel braced frames or buckling-restrained braced frames)



Structure entirely made of wood, except for the columns and bracings, made of steel



Structure incorporating a mix of wood, steel, or concrete elements, regardless of their structural function (e.g., some beams in wood and others in steel, portions of the lateral system in steel and others in concrete, etc.)



Key Elements of a Successful Hybrid Project

The general contractor plays a critical role by bringing together various specialists (subcontractors) to ensure that everyone works in harmony toward a cohesive outcome and a successful project. The primary challenge in a hybrid structure lies in coordinating the different stakeholders: aligning design, schedule, scope of work, and material tolerances is essential.

The following elements are crucial for ensuring effective collaboration between the mass timber subcontractor and the steel subcontractor on a hybrid building:

- Communicating clearly:
 - Establish formal communication channels (regular coordination meetings, shared platforms, scheduled 3D model exchanges, etc.).
 - Ensure that the scope of work, deliverables, schedule, and applicable standards are clearly understood.
- Defining expectations:
 - Clearly define the scope of work for each stakeholder, including deliverables and responsibilities.
 - Establish a detailed schedule for each subcontractor and define key milestones.
- Managing conflicts:
 - Implement a clear protocol for managing conflicts.
 - Among other things, define expectations regarding connection tolerances.
 - Specify the roles and responsibilities of each party if corrective work becomes necessary.

Even in well-coordinated projects, errors and incompatibilities can arise on site. Establishing clear procedures ahead of time facilitates the work, reduces potential friction, and increases the likelihood of project success.

Design Process – Workflow

In hybrid wood–steel structures, coordinating the interfaces between the two materials is a critical step. Rigorous planning at this stage is essential to ensure project success and to prevent unforeseen issues or erection delays.

The development of wood–steel connections is an iterative process. This process involves several stakeholders, including Nordic Structures, the steel fabricator/detailer, the Engineer of Record (EOR), and the Architect of Record (AOR). Each party plays a specific role and assumes responsibilities in the design of the connections.

The installation sequence must be coordinated among the stakeholders (general contractor, EOR, steel fabricator, Nordic Structures) to ensure compatibility between the connections' concepts and the erection sequence.

Refer to Table 2 and Figure 1 for further details.

Table 2 – Roles and Responsibilities

EOR/AOR

- Define design loads (shear, axial, torsion, etc.).
- Provide design criteria (fire resistance, stiffness, architectural/visual requirements, etc.).
- Provide typical conceptual details illustrating the expected connection principles.
- Review shop drawings for the connections to check compliance.

Nordic Structures

- Develop detailed designs for all wood–steel connection types and sub-types, ensuring that all potential failure modes in the wood are fully checked.
- Provide minimum requirements for the steel components (bolt spacing, locations of slotted holes, minimum bearing surfaces, etc.).
- Prepare an initial draft of the connection details within a 3D model and produce coordination drawings for the steel fabricator/detailer, as well as for review by the design team. (See example coordination drawings in the appendix.)
- Incorporate comments from the steel fabricator and the design team into the final connection details.
- Exchange 3D models for clash detection (BIM coordination).
- Provide shop drawings for the mass timber elements, including all machining required to accommodate the steel connectors.

Steel Fabricator / Detailer

- Review Nordic Structures' wood–steel coordination drawings and provide feedback related to steel failure modes.
 - Determine steel plate thicknesses and specify welding requirements.
 - Mark up Nordic Structures' coordination drawings with the steel design information.
 - Exchange 3D models for clash detection (BIM coordination).
 - Provide shop drawings for the steel components, including all wood–steel connection assemblies.
-

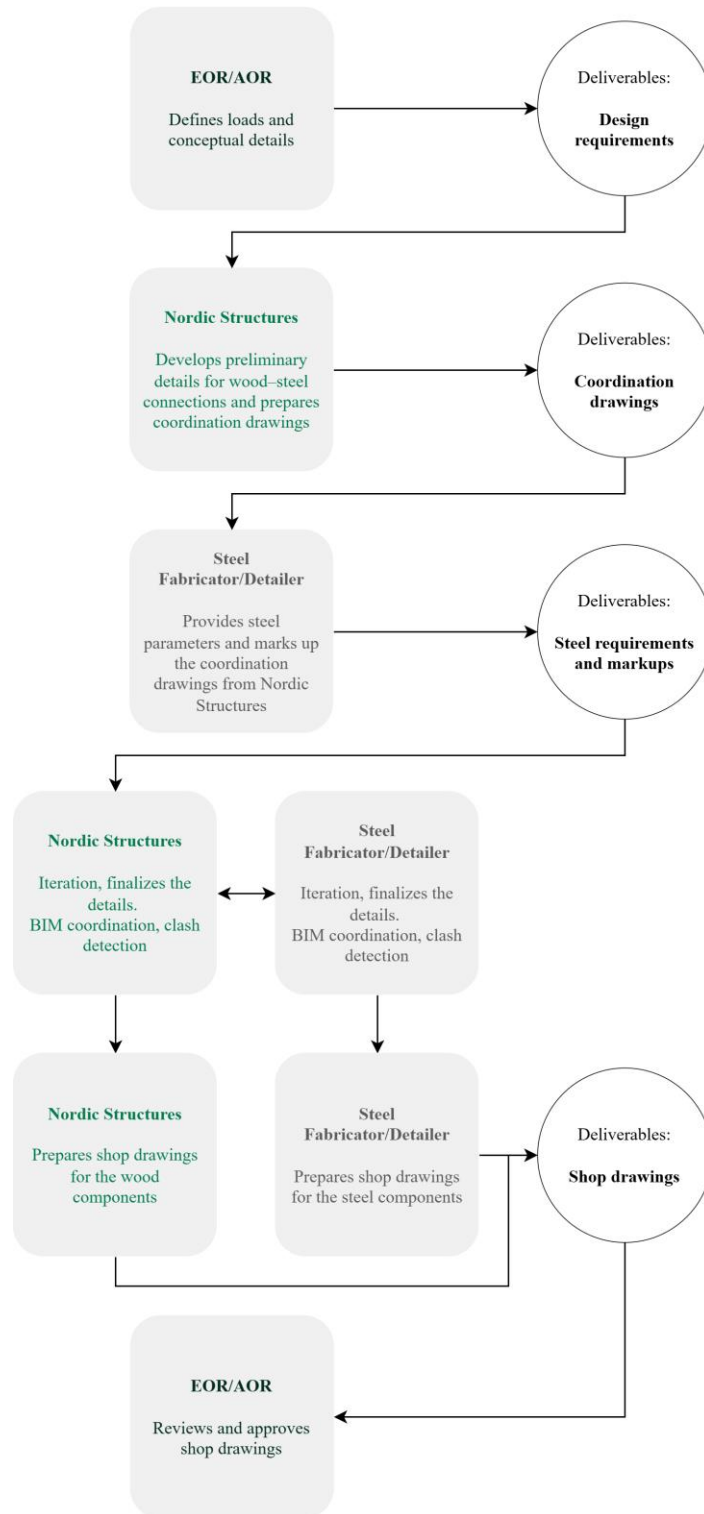

Figure 1 – Workflow

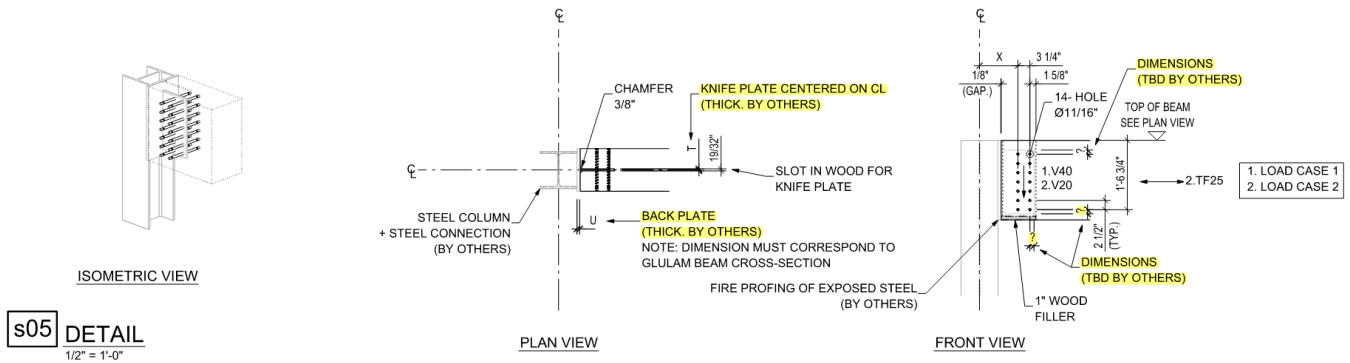

Figure 2 – Example of a Preliminary Connection Concept Considering Wood Failure Modes

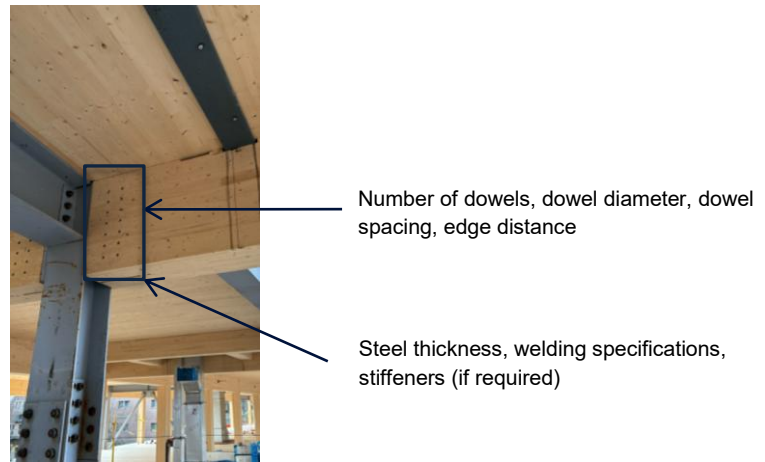

Figure 3 – Final Result on Site

Tolerances

The concrete foundation tolerances and the steel erection tolerances must be taken into account when designing wood–steel connections. Wherever possible, slotted holes in the steel components should be used to accommodate these tolerances. When feasible, the erection tolerances for the structural steel should be more stringent than those typically permitted by applicable standards.

The following recommendations are intended to facilitate the installation of the mass timber structure:

- Do not grout the steel column base plates until the entire mass timber structure for that level has been installed. This allows the erection crew to loosen the anchor bolts and rotate the steel column if necessary.
- Do not fully tighten the bolts in steel-to-steel connections so that the erection crew can pull or shift steel elements into position if needed—for example, in bracing areas.
- Ensure that a skilled worker specialized in steel components is present on site during the erection of the mass timber structure to address any steel components that do not fit properly.

Fire Resistance (When Required)

In certain projects, a fire-resistance rating must be provided for both the structure and the connections. Mass timber can inherently provide fire resistance and can protect the steel components when properly designed. When a fire-resistance rating is specified on the construction

documents, Nordic Structures designs the connection to meet this requirement. In general, the steel connector is fully concealed within the wood member, and wood plugs and blocking are provided.

Fire protection for the steel structure must be applied after the mass timber structure has been erected. Wood must be masked and protected before applying the fire-protection system.



Figure 4 – Steel Structure with Cement-based Fire Protection



Figure 5 – Steel Structure with Intumescent Fire-protective Coating