

NORDIC

TECHNICAL GUIDE
NORDIC X-LAM

NS-GT6 

ASD

VERSION
2026-02-01

Mass Timber Construction

NORDIC X-LAM TECHNICAL GUIDE

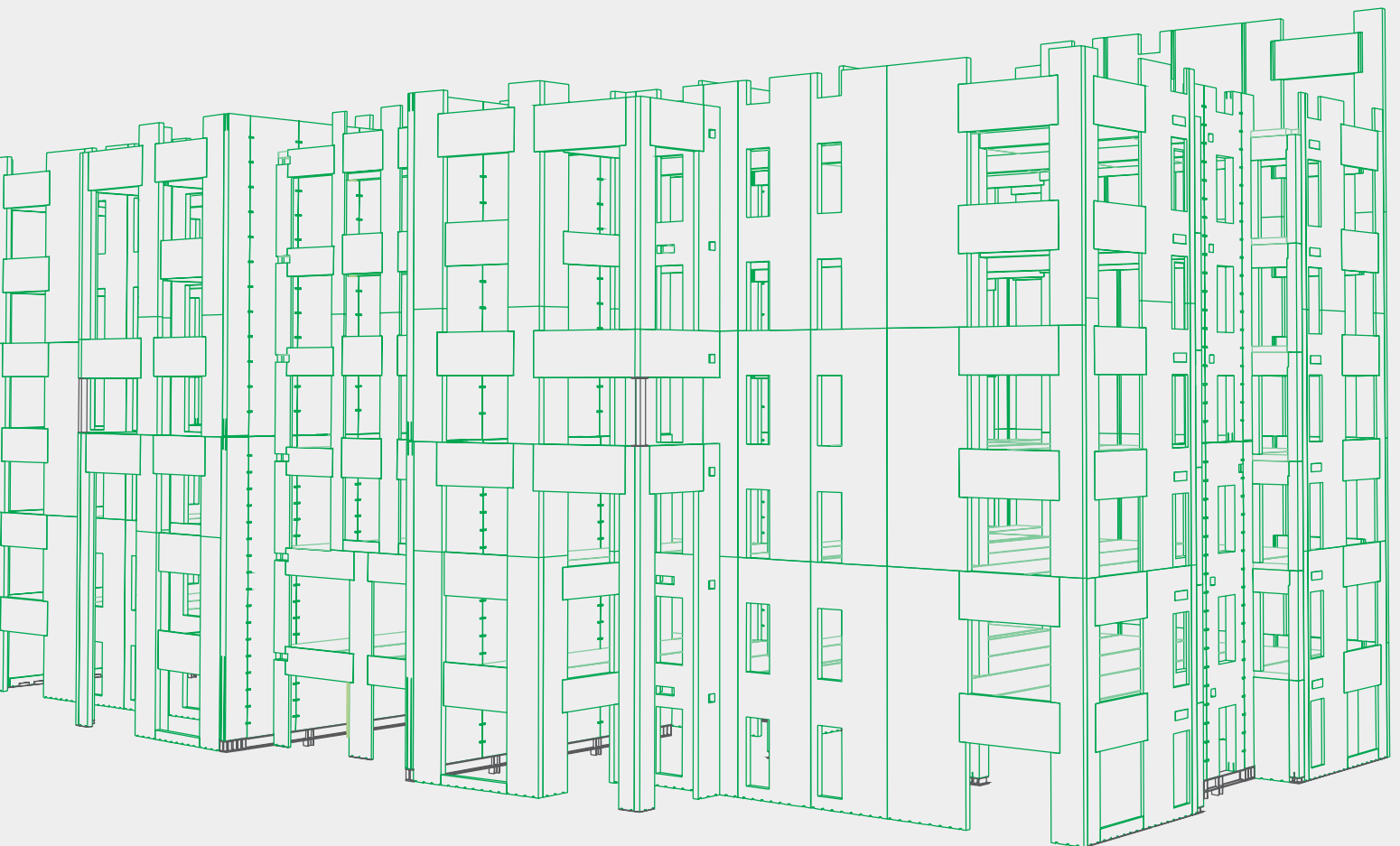

NORDIC
STRUCTURES

ABOUT NORDIC

NORDIC STRUCTURES

Nordic Structures is the leading innovator in mass timber construction. Its resource comes from responsibly managed lands within the regional boreal forest. Vertical integration, from forest to structure, bolstered by Nordic's experienced design and development team, ensures consistent quality and unparalleled level of service.

514-871-8526
1 866 817-3418

HEAD OFFICE

Nordic Structures

100-1100 Canadiens-de-Montréal Avenue
Montréal, Québec H3B 2S2

www.nordic.ca

GENERAL INFORMATION

info@nordic.ca

TECHNICAL SUPPORT

arch@nordic.ca

TABLE OF CONTENTS

NORDIC X-LAM

1

STRUCTURE

2

STRUCTURAL
DETAILS

3

ARCHITECTURAL
DETAILS

4

ADDITIONAL
INFORMATION

5

ENGINEERED WOOD PRODUCTS

Standard size products available from our distributors

NS-GT3



NORDIC I-JOISTS

Nordic I-joists are composed of sawn lumber flanges connected by a structural oriented strand board and bonded together with exterior-grade adhesives.

NI-40x

2x3 1950f MSR, 3/8 in. web

Depths

9-1/2, 11-7/8 and 14 in.

NI-60

2x3 2100f MSR, 3/8 in. web

Depths

9-1/2, 11-7/8, 14 and 16 in.

NI-80

2x4 2100f MSR, 3/8 in. web

Depths

9-1/2, 11-7/8, 14 and 16 in.

NI-90

2x4 2400f MSR, 7/16 in. web

Depths

11-7/8, 14 and 16 in.

RESIDENTIAL SERIES

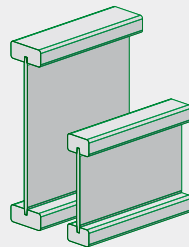

NI-80x

2x4 2100f MSR, 7/16 in. web

Depths

18, 20, 22 and 24 in.

COMMERCIAL SERIES

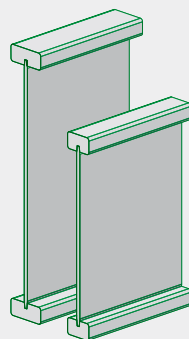

NS-GT4



NORDIC LAM GLUED-LAMINATED TIMBER

Nordic Lam glued-laminated timber of industrial appearance classification consists of small wood laminations bonded together in parallel using structural adhesives.

BEAMS AND HEADERS

Widths

1-3/4, 3-1/2, 5-1/2 and 7 in.

Depths

9-1/2, 11-7/8, 14, 16, 18, 20, 22 and 24 in.

Lengths*

Up to 48 ft

Stress grade

24F-1.9E

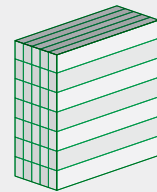

COLUMNS

Widths

3-1/2, 5-1/2 and 7 in.

Depths

3-1/2, 5-1/2 and 7 in.

Lengths*

Up to 48 ft

Stress grade

ES12

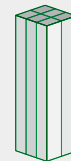

STUDS

Widths

1-1/2 and 1-3/4 in.

Depths

5-1/2 and 7-1/4 in.

Lengths*

Up to 48 ft

Stress grade

ES11

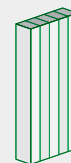

* Larger sizes available upon request

MASS TIMBER CONSTRUCTION

Products custom-manufactured
and machined for major projects

NS-GT5



NORDIC LAM+ GLUED-LAMINATED TIMBER

Nordic Lam+ glued-laminated timber of architectural appearance classification consists of small wood laminations bonded together in parallel using structural adhesives.

BEAMS AND COLUMNS

Widths*

38, 86, 137, 184, 216, 241, 292, 346, 394, 448, 502, 552 and 603 mm
(1-1/2, 3-3/8, 5-3/8, 7-1/4, 8-1/2, 9-1/2, 11-1/2, 13-5/8, 15-1/2,
17-5/8, 19-3/4, 21-3/4 and 23-3/4 in.)

Depths*

From 67 to 2435 mm
(2-5/8 to 95-7/8 in.)

Lengths*

Up to 24.4 m (80 ft)

Stress grade

24F-ES/NPG

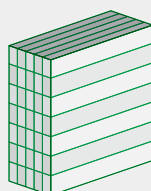

DECKING

Thicknesses*

38, 44, 54 and 89 mm
(1-1/2, 1-3/4, 2-1/8 and 3-1/2 in.)

Widths

203, 305 and 406 mm
(8, 12 and 16 in.)

Lengths

Up to 18.9 m (62 ft)

Stress grades

ES11, except 89 mm thickness in 20F-ES/CPG

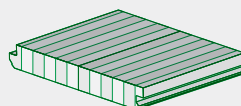

* Larger sizes available upon request

NS-GT6



NORDIC X-LAM CROSS-LAMINATED TIMBER

Nordic X-Lam cross-laminated timber is made of at least three orthogonal layers of graded sawn lumber that are laminated by gluing with structural adhesives.

SLABS AND PANELS

Layup combinations

89-3s, 105-3s,
143-5s, 175-5s,
197-7s, 213-7l, 245-7s, 245-7l
and 267-9l

Maximum sizes

2.565 × 19.5 m (101 in. × 64 ft)

Stress grade

E1 (L 1950Fb and T No. 3/Stud)

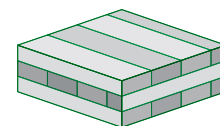

NORDIC

TECHNICAL GUIDE
NORDIC X-LAM

NS-GT6 

ASD

VERSION
2026-02-01

NORDIC X-LAM

1

NORDIC
STRUCTURES

CLT



NORDIC X-LAM CROSS-LAMINATED TIMBER

Nordic X-Lam cross-laminated timber is made of at least three orthogonal layers of graded sawn lumber that are laminated by gluing with structural adhesives.

SLABS AND PANELS

Layup combinations

89-3s, 105-3s,
143-5s, 175-5s,
197-7s, 213-7l, 245-7s, 245-7l
and 267-9l

Maximum sizes

2.565 × 19.5 m (101 in. × 64 ft)

Stress grade

E1 (L 1950Fb and T No. 3/Stud)

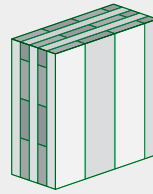
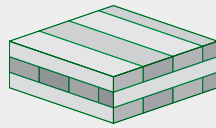

NORDIC X-LAM LAYUP COMBINATIONS

3 LAYERS

89-3s

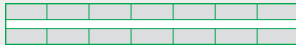

105-3s

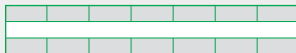

5 LAYERS

143-5s

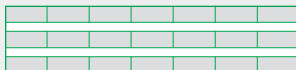

175-5s

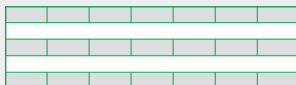

7 LAYERS

197-7s

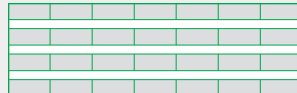

213-7l

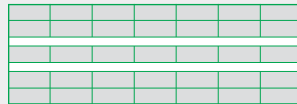

245-7s

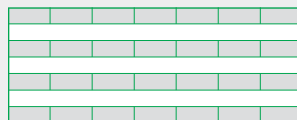

245-7l

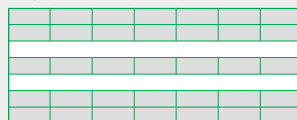

9 LAYERS

267-9l

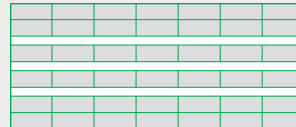

Nordic X-Lam – Specification Guide

Specifications

Cross-laminated timber (CLT) products shall be used in dry service conditions, such as in most covered structures, where the average equilibrium moisture content of solid wood is less than 16 percent. CLT products are intended to resist the effects of moisture on structural performance as may occur due to construction delays or other conditions of similar severity.

Master format 06 17 19

REFERENCE STANDARD

- .1 ANSI/APA PRG 320-[2018], Standard for Performance-Rated Cross-Laminated Timber.

ACTION AND INFORMATION SUBMITTALS

- .1 Submit the product report published by a certification agency accredited by the International Accreditation Service at completion of fabrication.

MATERIALS

- .1 Laminating stock: Spruce-Pine-Fir, [FSC certified]
- .2 Sealer: Penetrating type, clear sealer (Sansin KP-12UVW) applied only to exposed (architectural-grade) surfaces
- .3 Preservative: [Specify as required]
- .4 Fire retardant: [Specify as required]

FABRICATION

- .1 Stress grade: E1
- .2 Service grade: Interior
- .3 Appearance classification:
SPEC NOTE: Typically, only the exposed (visible) surfaces are of architectural appearance grade.
Faces: [industrial (U.N.O.)] [one industrial face – one architectural face] [architectural]
Edges: industrial
Note: Laminations are not edge-glued; Panel edges are not meant to be showcased.
- .4 Fire resistance: [Specify as required]

ERECTION

- .1 Erect cross-laminated timber members in accordance with erection drawings issued for construction.

For the detailed specification guide: <https://www.nordic.ca/en/documentation/technical-documents>

Nordic X-Lam – Appearance Classifications

The following examples of CLT appearance classifications are for reference only. These requirements are based on the appearance at the time of manufacturing. The actual CLT product appearance requirements are recommended to be agreed upon between the buyer and the seller.



Industrial Appearance

An appearance classification normally suitable for use in concealed applications where appearance is not of primary concern. Specific characteristics of this classification are as follows:

- Voids appearing on the edges of laminations need not be filled.
- Loose knots and knot holes appearing on the face layers exposed to view are not filled.
- Members are surfaced on face layers only and the appearance requirements apply only to these layers.
- Occasional misses, low laminations or wane (limited to the lumber grade) are permitted on the surface layers and are not limited in length.



Architectural Appearance

An appearance classification normally suitable for applications where appearance is an important but not overriding consideration. Specific characteristics of this classification are as follows:

- In exposed surfaces, all knot holes and voids measuring over 3/4 inch are filled with a wood-tone filler or clear wood inserts selected for similarity with the grain and color of the adjacent wood.
- The face layers exposed to view are free of loose knots and open knot holes are filled.
- Knot holes do not exceed 3/4 inch when measured in the direction of the lamination length with the exception that a void may be longer than 3/4 inch if its area is not greater than 1/2 inch².
- Voids greater than 1/16 inch wide created by edge joints appearing on the face layers exposed to view are filled.
- Exposed surfaces are surfaced smooth with no misses permitted.

Nordic X-Lam – Certifications

Product Certifications

Nordic X-Lam cross-laminated timber (CLT) products, certified by APA – The Engineered Wood Association (apawood.org), are manufactured in accordance with the applicable standards and associated specifications indicated below:

- ANSI/APA PRG 320, Standard for Performance-Rated Cross-Laminated Timber
- ICC-ES–APA Joint Evaluation Report ESR-4875
- APA Product Report PR-L306

APA is a not-for-profit trade association and is accredited by the International Accreditation Service (IAS), a subsidiary of ICC, as an independent Inspection Agency under ISO/IEC 17020. APA is also an accredited testing organization recognized by IAS under ISO/IEC 17025.

The ANSI/APA PRG 320 standard is recognized in the International Building Code (IBC) and is required for using the design provisions specified in the National Design Specification (NDS) for Wood Construction.

Green Certifications

Wood – efficient and ecological

Overview of environmental certifications:

- Green Verification Report APA GR-L306
- Low Formaldehyde Emissions Products APA PR-E740
- Environmental Product Declaration (EPD), Nordic X-Lam
- Health Product Declaration (HPD), Nordic X-Lam
- Declare (ILFI), Nordic X-Lam
- Home Innovation NGBS Green Certified, Certificate #00230
- USDA Certified Biobased Product, Product 100%
- Cradle to Cradle Certified, Nordic X-Lam
- FSC-certified products available

Note: For independently verified ICC 700 NGBS (National Green Building Standard) and LEED (Leadership in Energy and Environmental Design) points, refer to APA GR-L306.

See nordic.ca for details.

Nordic X-Lam – Transparency Brief

The Nordic X-Lam business-to-business environmental product declaration (EPD) is based on a cradle-to-gate life cycle analysis (LCA). The delivery of the product to the customer, its use and eventual end-of-life processing are excluded from the EPD.

Forest Operations

The assessment of the life cycle impacts of Nordic wood product begins with its origin in managed forests and the energy use and emissions caused by its extraction. Forest management and reforestation that occurs after extraction are also included.

Nordic is committed to sustainable forestry as defined in the Forest Stewardship Council (FSC) forest management certification. Nordic's wood fiber sources fall into the following category:

- Certified sources of wood fiber come from FSC certified forests

CLT Production

The cross-laminated timber (CLT) production phase begins with the transportation of logs to the finished product. These processes consume fossil fuel (65.7%), electricity drawn from regional grids (22.5%), internally generated biomass (9.4%) and nuclear (2.4%).

Environmental Impacts

Atmosphere

Global warming potential	121.89 kg CO ₂ eq.
Ozone depletion potential	1.79E-06 kg CFC-11 eq.
Photochemical ozone creation potential	35.53 kg O ₃ eq.

Water

Acidification potential	1.19 kg SO ₂ eq.
Eutrophication potential	0.11 kg N eq.

Earth

Depletion of abiotic resources (elements)	38.84 kg
Depletion of abiotic resources (fossil fuels)	1831.88 MJ

Material Content

Component – for 1 m ³ of Nordic X-Lam	Mass (kg)	Mass (%)
Wood (on oven dry basis); renewable	406 kg	98.9 %
Resins (polyurethane and isocyanate)	4.46 kg	1.1 %
Total	410.46 kg	100 %

Carbon Balance

Impact Category – for 1 m ³ of Nordic X-Lam	Carbon (kg of CO ₂ eq.)
Forest carbon uptake	-741.36 kg of CO ₂ eq.
Life cycle greenhouse gas emissions	121.89 kg of CO ₂ eq.
Unaccounted biogenic carbon emissions	28.50 kg of CO ₂ eq.
Net global warming potential	-590.97 kg of CO ₂ eq.

See nordic.ca for details.

NORDIC

TECHNICAL GUIDE
NORDIC X-LAM

NS-GT6 

ASD

VERSION
2026-02-01

STRUCTURE

2



Nordic X-Lam – Design Properties

Characteristics

Nordic X-Lam cross-laminated timber (CLT) is certified according to E1 CLT stress grade, using 1950f-1.7E Spruce-Pine-Fir (S-P-F) MSR lumber in longitudinal layers and No. 3 S-P-F lumber in the transverse layers. Nordic X-Lam products are certified by APA (Product Report PR-L306) per the ANSI/APA PRG 320 Standard and shall be used in dry service conditions.

Material Design Properties

CLT stress grade	E1	
	Layers	
Orientation	Longitudinal	Transversal
Species combination	S-P-F	S-P-F
Stress class	1950f-1.7E MSR	No. 3
Bending at extreme fiber, F_b (psi)	1,950	500
Shear parallel to grain, F_v (psi)	135	135
Rolling shear, F_s (psi)	45	45
Compression parallel to grain, F_c (psi)	1,800	650
Compression perpendicular to grain, F_{cp} (psi)	425	425
Tension parallel to grain, F_t (psi)	1,375	250
Modulus of elasticity, E (psi)	1,700,000	1,200,000
Shear modulus, G (psi)	106,250	75,000
Rolling shear modulus, G_s (psi)	10,625	7,500

Note:

1. Appearance grades as defined in ANSI/APA PRG 320 do not affect the structural performance of CLT panels.

Panel Layups

Layup ^(a)	Thickness and orientation of layers ^(b)	Number of layers	Thickness		Weight		
			(mm)	(in.)	(kg/m ²)	(kN/m ²)	(psf)
89-3s	35L - 19T - 35L	3	89	3-1/2	45.8	0.45	9.38
105-3s	35L - 35T - 35L	3	105	4-1/8	54.0	0.53	11.1
143-5s	35L - 19T - 35L - 19T - 35L	5	143	5-5/8	73.6	0.72	15.1
175-5s	35L - 35T - 35L - 35T - 35L	5	175	6-7/8	89.9	0.88	18.4
197-7s	35L - 19T - 35L - 19T - 35L - 19T - 35L	7	197	7-3/4	101	0.99	20.8
213-7l	35L - 35L - 19T - 35L - 19T - 35L - 35L	7	213	8-3/8	110	1.07	22.4
245-7s	35L - 35T - 35L - 35T - 35L - 35T - 35L	7	245	9-5/8	126	1.24	25.9
245-7l	35L - 35L - 35T - 35L - 35T - 35L - 35L	7	245	9-5/8	126	1.24	25.9
267-9l	35L - 35L - 19T - 35L - 19T - 35L - 19T - 35L - 35L	9	267	10-1/2	137	1.35	28.1

a) The layup designation refers to the panel thickness (in mm), the number of layers, and the layer orientations ("s" for standard perpendicular layers, and "l" for doubled outermost parallel layers).

b) L = longitudinal, T = transversal, 35 = 1-3/8 in. = 34.925 mm, 19 = 3/4 in. = 19.05 mm

Floor/Roof Slabs – Design Properties

Floor/Roof Slabs – Design Properties

CLT stress grade	E1 (L = S-P-F 1950f MSR and T = S-P-F No. 3)								
	89-3s	105-3s	143-5s	175-5s	197-7s	213-7l	245-7s	245-7l	267-9l
Bending in the major strength direction									
Effective flatwise bending moment capacity, $M_{eff,f,0}$ (lb-ft/ft) ^(a)	3,350	4,525	7,725	10,400	13,725	18,700	18,375	23,700	28,325
Flatwise shear capacity, $V_{s,0}$ (lb/ft)	1,260	1,490	2,030	2,480	2,800	3,025	3,475	3,475	3,775
Effective flatwise bending stiffness, $(EI)_{eff,f,0}$ (10^6 lb-ft ² /ft)	72	115	267	440	654	963	1,089	1,404	1,831
Effective shear stiffness in flatwise bending, $(GA)_{eff,f,0}$ (10^6 lb/ft)	0.48	0.46	0.96	0.92	1.4	1.6	1.4	1.4	2.0
Bending in the minor strength direction									
Effective flatwise bending moment capacity, $M_{eff,f,90}$ (lb-ft/ft) ^(a)	45	160	615	1,370	1,410	615	3,150	1,370	1,410
Flatwise shear capacity, $V_{s,90}$ (lb/ft)	270	495	1,040	1,490	1,800	1,040	2,480	1,490	1,800
Effective flatwise bending stiffness, $(EI)_{eff,f,90}$ (10^6 lb-ft ² /ft)	0.51	3.1	26	81	101	26	313	81	101
Effective shear stiffness in flatwise bending, $(GA)_{eff,f,90}$ (10^6 lb/ft)	0.39	0.61	0.78	1.2	1.2	0.93	1.8	1.3	1.3

a) The effective flatwise bending moment capacity values in the major strength direction, $M_{eff,f,0}$, include the adjustment factor of 0.85 from ANSI/APA PRG 320.

Notes:

1. The tabulated design values are for dry service conditions and normal duration of loading.
2. The compressive capacity perpendicular to grain values shall be based on S-P-F No. 3 lumber ($f_{cp} = 425$ psi).
3. The specific gravity for dowel-type fastener design is 0.42.
4. The density for member weight is 32 pcf for a moisture content of 12%.
5. Design of CLT members shall be in accordance with the NDS.

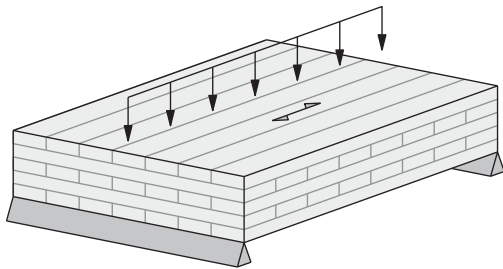

Bending in the major strength direction

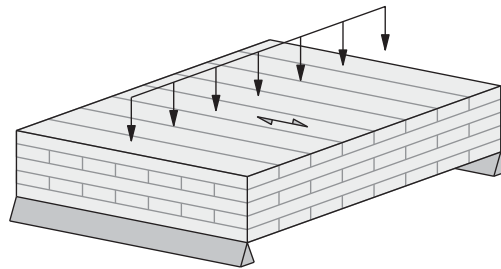

Bending in the minor strength direction

Floor Slabs – Sizing

Live load = 40 psf – Simple Span

Layup selection

Dead load ^(a) (psf)	L (ft) ^(b, c)															
	8	9	10	11	12	13	14	15	16	17	18	19	20	21	22	
20	89-3s	89-3s	89-3s	89-3s	89-3s	105-3s	143-5s	143-5s	143-5s	143-5s	143-5s	175-5s	175-5s	197-7s	197-7s	213-7l
30				105-3s	105-3s	175-5s				175-5s	197-7s	213-7l				
40		105-3s	105-3s	143-5s	143-5s	143-5s	175-5s	175-5s	197-7s	197-7s	213-7l	213-7l	245-7s			
50		105-3s	105-3s											197-7s	213-7l	245-7s
60		105-3s	105-3s	143-5s	143-5s	143-5s	175-5s	175-5s	197-7s	197-7s	213-7l	213-7l	245-7s			
70		105-3s	105-3s											197-7s	213-7l	245-7s
80		105-3s	143-5s	143-5s	143-5s	143-5s	175-5s	175-5s	197-7s	197-7s	213-7l	213-7l	245-7s			
80		105-3s	143-5s											197-7s	213-7l	245-7s

Live load = 40 psf – Double Span

Layup selection

Dead load ^(a) (psf)	L (ft) ^(b, d)														
	8	9	10	11	12	13	14	15	16	17	18	19	20	21	22
20	89-3s	89-3s	89-3s	89-3s	89-3s	89-3s	105-3s	105-3s	143-5s	143-5s	143-5s	175-5s	175-5s	197-7s	197-7s
30				89-3s	89-3s	105-3s						105-3s			
40		89-3s	89-3s	89-3s	89-3s	105-3s	105-3s	143-5s	143-5s	143-5s	143-5s	175-5s	175-5s	197-7s	197-7s
50		89-3s	89-3s	89-3s											
60		89-3s	89-3s	89-3s	89-3s	105-3s	105-3s	143-5s	143-5s	143-5s	143-5s	175-5s	175-5s	197-7s	197-7s
70		89-3s	89-3s												
80		89-3s	89-3s	89-3s	105-3s	105-3s	143-5s	143-5s	143-5s	143-5s	143-5s	175-5s	175-5s	197-7s	197-7s

- a) The panel self weight is considered in the calculation and shall not be included in the dead load.
- b) Span is measured center to center of supports.
- c) The maximum spans for vibration control, l_v , are increased by 10% as recommended by Nordic Structures.
- d) The maximum spans for vibration control, l_v , are increased by 20% for non-structural elements that are considered to provide enhanced vibration effect.

Notes:

1. For preliminary design use only. Final design shall include a complete analysis including the verification of the bearing capacity.
2. Tables are based on uniform loads and dry service conditions, for bending in the major strength direction of the panel.
3. Tabulated values take into account the bending moment and shear capacities, a live load deflection limit of $L/360$, a total load deflection limit of $L/240$, and include a consideration for floor vibration. The maximum spans for vibration control, l_v , are based on Clause A.8.5.3 of the Update No. 1 of CSA O86-14.
4. Fire-resistance rating takes into account the bending moment and shear capacities of the reduced cross-section.
5. Fire-resistance rating:

30 min	60 min	90 min	120 min
--------	--------	--------	---------

Live load = 50 psf – Simple Span

Layup selection

Dead load ^(a) (psf)	L (ft) ^(b, c)															
	8	9	10	11	12	13	14	15	16	17	18	19	20	21	22	
20	89-3s	89-3s	89-3s	89-3s	105-3s	143-5s	143-5s	143-5s	143-5s	175-5s	175-5s	175-5s	197-7s	197-7s	213-7l	
30			105-3s	105-3s	175-5s			175-5s	197-7s	213-7l						
40			105-3s	143-5s	175-5s			197-7s	213-7l							
50			105-3s	143-5s	175-5s			197-7s	213-7l							
60		105-3s	105-3s	143-5s	143-5s	175-5s	175-5s	197-7s	213-7l	213-7l	245-7s	245-7l	245-7l	267-9l		
70															105-3s	143-5s
80			143-5s	175-5s	197-7s	213-7l	245-7s	245-7l	267-9l							

Live load = 50 psf – Double Span

Layup selection

Dead load ^(a) (psf)	L (ft) ^(b, d)															
	8	9	10	11	12	13	14	15	16	17	18	19	20	21	22	
20	89-3s	89-3s	89-3s	89-3s	89-3s	89-3s	105-3s	105-3s	143-5s	143-5s	143-5s	175-5s	175-5s	197-7s	197-7s	
30				89-3s	105-3s	143-5s	143-5s	175-5s	197-7s	213-7l						
40				89-3s	105-3s	143-5s	175-5s	197-7s	213-7l							
50				89-3s	105-3s	143-5s	175-5s	197-7s	213-7l							
60		89-3s	89-3s	105-3s	105-3s	143-5s	143-5s	143-5s	175-5s	175-5s	197-7s	197-7s	213-7l	213-7l		
70															105-3s	143-5s
80			105-3s	143-5s	175-5s	197-7s	213-7l									

- a) The panel self weight is considered in the calculation and shall not be included in the dead load.
- b) Span is measured center to center of supports.
- c) The maximum spans for vibration control, l_v , are increased by 10% as recommended by Nordic Structures.
- d) The maximum spans for vibration control, l_v , are increased by 20% for non-structural elements that are considered to provide enhanced vibration effect.

Notes:

1. For preliminary design use only. Final design shall include a complete analysis including the verification of the bearing capacity and of a concentrated live load as defined in IBC 1607.4 (if applicable).
2. Tables are based on uniform loads and dry service conditions, for bending in the major strength direction of the panel.
3. Tabulated values take into account the bending moment and shear capacities, a live load deflection limit of $L/360$, a total load deflection limit of $L/240$, and include a consideration for floor vibration. The maximum spans for vibration control, l_v , are based on Clause A.8.5.3 of the Update No. 1 of CSA O86-14.
4. Fire-resistance rating takes into account the bending moment and shear capacities of the reduced cross-section.
5. Fire-resistance rating:

30 min	60 min	90 min	120 min
--------	--------	--------	---------

Live load = 100 psf – Simple Span

Layup selection

Dead load ^(a) (psf)	L (ft) ^(b, c)															
	8	9	10	11	12	13	14	15	16	17	18	19	20	21	22	
20	89-3s	89-3s	105-3s	105-3s	143-5s	143-5s	143-5s	175-5s	175-5s	197-7s	197-7s	197-7s	213-7l	213-7l	245-7s	
30																
40																
50																
60		105-3s	143-5s	143-5s	143-5s	175-5s	175-5s	197-7s	197-7s	197-7s	213-7l	213-7l	245-7s	245-7l	267-9l	
70																
80	105-3s	143-5s								213-7l						

Live load = 100 psf – Double Span

Layup selection

Dead load ^(a) (psf)	L (ft) ^(b, d)															
	8	9	10	11	12	13	14	15	16	17	18	19	20	21	22	
20	89-3s	89-3s	89-3s	105-3s	105-3s	143-5s	143-5s	143-5s	143-5s	175-5s	175-5s	175-5s	175-5s	197-7s	197-7s	
30																
40																
50																
60		89-3s	105-3s	105-3s	143-5s	143-5s	143-5s	143-5s	175-5s	175-5s	175-5s	197-7s	197-7s	213-7l	213-7l	
70																
80	89-3s		105-3s								197-7s					

- a) The panel self weight is considered in the calculation and shall not be included in the dead load.
- b) Span is measured center to center of supports.
- c) The maximum spans for vibration control, l_v , are increased by 10% as recommended by Nordic Structures.
- d) The maximum spans for vibration control, l_v , are increased by 20% for non-structural elements that are considered to provide enhanced vibration effect.

Notes:

1. For preliminary design use only. Final design shall include a complete analysis including the verification of the bearing capacity and of a concentrated live load as defined in IBC 1607.4 (if applicable).
2. Tables are based on uniform loads and dry service conditions, for bending in the major strength direction of the panel.
3. Tabulated values take into account the bending moment and shear capacities, a live load deflection limit of $L/360$, a total load deflection limit of $L/240$, and include a consideration for floor vibration. The maximum spans for vibration control, l_v , are based on Clause A.8.5.3 of the Update No. 1 of CSA O86-14.
4. Fire-resistance rating takes into account the bending moment and shear capacities of the reduced cross-section.
5. Fire-resistance rating:

30 min	60 min	90 min	120 min
--------	--------	--------	---------

Floor Slabs – Selection Tables

Bending Moment and Shear Capacities

Allowable uniform total load (psf)

L ^(a) (ft)	Layup								
	89-3s	105-3s	143-5s	175-5s	197-7s	213-7l	245-7s	245-7l	267-9l
10.0	211	252							
10.5	201	240							
11.0	191	228							
11.5	183	218							
12.0	175	208	289						
12.5	168	199	276						
13.0	159	191	265						
13.5	147	184	255						
14.0	137	177	245						
14.5	127	171	236	292					
15.0	119	161	228	282					
15.5	112	151	220	272					
16.0	105	141	213	263	299				
16.5	98	133	206	255	290				
17.0	93	125	200	247	281				
17.5	88	118	194	239	272	295			
18.0	83	112	188	232	264	287			
18.5	78	106	181	226	256	278			
19.0	74	100	171	219	249	271			
19.5	70	95	163	214	243	263			
20.0	67	91	155	208	236	256	297	297	
20.5	64	86	147	198	230	250	289	289	
21.0	61	82	140	189	224	243	282	282	
21.5	58	78	134	180	219	237	275	275	
22.0	55	75	128	172	214	232	268	268	293
22.5	53	72	122	164	209	226	262	262	286
23.0	51	68	117	157	204	221	256	256	280
23.5		66	112	151	199	216	250	250	273
24.0		63	107	144	191	212	245	245	267
24.5		60	103	139	183	207	239	239	261
25.0		58	99	133	176	203	234	234	256
25.5		56	95	128	169	198	226	230	251

Bending moment and shear capacities

- $M_0 \geq M$ and $V_0 \geq V$

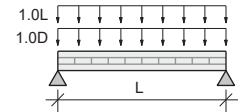
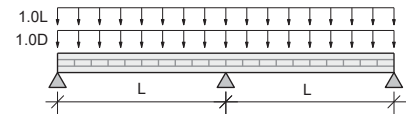

a) Span is measured center to center of supports.

Notes:

1. For preliminary design use only. Final design shall include a complete analysis including the verification of the bending moment, shear, and bearing capacities and a consideration for live load and total load deflections. If applicable, the final design shall include a consideration for floor vibration, the verification of a concentrated live load as defined in IBC 1607.4, and fire-resistance requirements.
2. The tabulated values are based on dry service conditions, normal duration of loading, and the most restrictive of simple span or double span, for bending in the major strength direction of the panel.

L/240 Deflection Limit – Simple Span

Allowable uniform total load (psf)

L ^(a) (ft)	Layup								
	89-3s	105-3s	143-5s	175-5s	197-7s	213-7l	245-7s	245-7l	267-9l
10.0	95	142	324						
10.5	83	125	284						
11.0	73	110	251	372					
11.5	64	97	223	332					
12.0	57	87	198	298					
12.5	51	77	177	268	400				
13.0		69	159	242	361				
13.5		62	143	219	327				
14.0		56	129	199	297				
14.5		51	117	181	270	381			
15.0			107	165	246	348	374		
15.5			97	151	225	319	344		
16.0			89	138	206	293	317	387	
16.5			81	127	190	270	292	358	
17.0			75	117	175	249	270	331	
17.5			69	108	161	230	250	308	
18.0			63	100	149	213	232	286	379
18.5			59	93	138	198	216	266	353
19.0			54	86	128	184	201	248	329
19.5				80	119	171	187	232	307
20.0				74	111	159	175	217	287
20.5				69	103	149	163	203	268
21.0				65	96	139	153	190	251
21.5				61	90	130	143	178	236
22.0				57	84	122	134	168	221
22.5				53	79	114	126	158	208
23.0					74	107	119	148	196
23.5					70	101	112	140	185
24.0					66	95	105	132	174
24.5					62	90	99	125	164
25.0					59	85	94	118	155
25.5					55	80	89	112	147

Deflection limit
• $K_{cr} \Delta_{LT} + \Delta_{ST} \leq L/240$

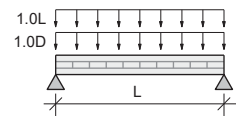

a) Span is measured center to center of supports.

Notes:

1. For preliminary design use only. Final design shall include a complete analysis including the verification of the bending moment, shear, and bearing capacities and a consideration for live load and total load deflections. If applicable, the final design shall include a consideration for floor vibration, the verification of a concentrated live load as defined in IBC 1607.4, and fire-resistance requirements.
2. The tabulated values are based on dry service conditions, for bending in the major strength direction of the panel.
3. The above values apply to slabs with a dead load less or equal to the live load. If the dead load is greater than the live load, multiply the allowable uniform total load by the corresponding adjustment factor:

Adjustment factor based on dead load / live load ratio (D/L)

D/L	1.00	1.25	1.50	1.75	2.00	2.25	2.50	2.75	3.00
Factor	1.000	0.964	0.938	0.917	0.900	0.886	0.875	0.865	0.857

L/240 Deflection Limit – Double Span

Allowable uniform total load (psf)

L ^(a) (ft)	Layup								
	89-3s	105-3s	143-5s	175-5s	197-7s	213-7l	245-7s	245-7l	267-9l
10.0	170	241							
10.5	149	214							
11.0	132	190							
11.5	117	170	385						
12.0	104	152	346						
12.5	93	137	311						
13.0	84	124	281						
13.5	75	112	255	369					
14.0	68	102	232	338					
14.5	62	93	211	310					
15.0	56	84	193	285					
15.5	51	77	177	262	392				
16.0		71	162	242	362				
16.5		65	149	224	334				
17.0		60	137	207	309				
17.5		55	127	192	287	400			
18.0		51	117	178	266	373	395		
18.5			109	166	248	347	370		
19.0			101	155	231	324	346		
19.5			94	144	215	303	324	390	
20.0			88	135	201	284	304	367	
20.5			82	126	188	266	285	346	
21.0			76	118	176	249	268	326	
21.5			71	111	165	234	253	307	
22.0			67	104	155	220	238	290	386
22.5			63	98	146	207	224	274	365
23.0			59	92	137	196	212	259	345
23.5			55	87	129	184	200	245	326
24.0			52	82	122	174	189	232	309
24.5				77	115	165	179	220	293
25.0				73	109	156	170	209	278
25.5				69	103	148	161	199	263

Deflection limit
 • $K_{cr} \Delta_{LT} + \Delta_{ST} \leq L/240$

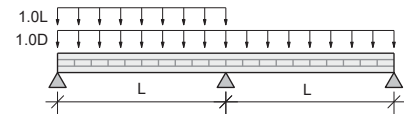

a) Span is measured center to center of supports.

Notes:

1. For preliminary design use only. Final design shall include a complete analysis including the verification of the bending moment, shear, and bearing capacities and a consideration for live load and total load deflections. If applicable, the final design shall include a consideration for floor vibration, the verification of a concentrated live load as defined in IBC 1607.4, and fire-resistance requirements.
2. The tabulated values are based on dry service conditions, for bending in the major strength direction of the panel.
3. The above values apply to slabs with a dead load less or equal to the live load. If the dead load is greater than the live load, multiply the allowable uniform total load by the corresponding adjustment factor:

Adjustment factor based on dead load / live load ratio (D/L)

D/L	1.00	1.25	1.50	1.75	2.00	2.25	2.50	2.75	3.00
Factor	1.000	0.964	0.938	0.917	0.900	0.886	0.875	0.865	0.857

L/360 Deflection Limit – Simple Span

Allowable uniform live load (psf)

L ^(a) (ft)	Layup								
	89-3s	105-3s	143-5s	175-5s	197-7s	213-7l	245-7s	245-7l	267-9l
10.0	95	142							
10.5	83	125							
11.0	73	110							
11.5	64	97							
12.0	57	87							
12.5	51	77	177						
13.0	45	69	159						
13.5	41	62	143						
14.0		56	129						
14.5		51	117						
15.0		46	107	165					
15.5		42	97	151					
16.0			89	138					
16.5			81	127					
17.0			75	117	175				
17.5			69	108	161				
18.0			63	100	149				
18.5			59	93	138				
19.0			54	86	128				
19.5			50	80	119	171			
20.0			47	74	111	159	175		
20.5			44	69	103	149	163		
21.0			41	65	96	139	153		
21.5				61	90	130	143	178	
22.0				57	84	122	134	168	
22.5				53	79	114	126	158	
23.0				50	74	107	119	148	
23.5				47	70	101	112	140	
24.0				44	66	95	105	132	174
24.5				42	62	90	99	125	164
25.0					59	85	94	118	155
25.5					55	80	89	112	147

Deflection limit
• $\Delta_L \leq L/360$

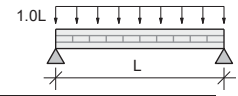

a) Span is measured center to center of supports.

Notes:

1. For preliminary design use only. Final design shall include a complete analysis including the verification of the bending moment, shear, and bearing capacities and a consideration for live load and total load deflections. If applicable, the final design shall include a consideration for floor vibration, the verification of a concentrated live load as defined in IBC 1607.4, and fire-resistance requirements.
2. The tabulated values are based on dry service conditions, for bending in the major strength direction of the panel.

L/360 Deflection Limit – Double Span

Allowable uniform live load (psf)

L ^(a) (ft)	Layup								
	89-3s	105-3s	143-5s	175-5s	197-7s	213-7l	245-7s	245-7l	267-9l
10.0	130								
10.5	114	167							
11.0	100	148							
11.5	88	131							
12.0	79	117							
12.5	70	105							
13.0	63	94							
13.5	56	85							
14.0	51	77	177						
14.5	46	70	161						
15.0	42	64	146						
15.5		58	134						
16.0		53	122						
16.5		49	112	172					
17.0		45	103	159					
17.5		41	95	147					
18.0			88	136					
18.5			81	126					
19.0			75	118	175				
19.5			70	109	163				
20.0			65	102	152				
20.5			61	95	142				
21.0			57	89	133				
21.5			53	84	124	178			
22.0			50	78	117	167			
22.5			47	74	110	157	172		
23.0			44	69	103	148	162		
23.5			41	65	97	139	153		
24.0				61	91	131	144	179	
24.5				58	86	124	136	169	
25.0				55	81	117	129	160	
25.5				52	77	111	122	152	

Deflection limit
 • $\Delta_L \leq L/360$

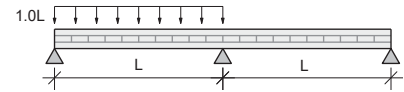

a) Span is measured center to center of supports.

Notes:

1. For preliminary design use only. Final design shall include a complete analysis including the verification of the bending moment, shear, and bearing capacities and a consideration for live load and total load deflections. If applicable, the final design shall include a consideration for floor vibration, the verification of a concentrated live load as defined in IBC 1607.4, and fire-resistance requirements.
2. The tabulated values are based on dry service conditions, for bending in the major strength direction of the panel.

Vibration, Simple Span

Maximum span, l_v (ft)

Span	Layup								
	89-3s	105-3s	143-5s	175-5s	197-7s	213-7l	245-7s	245-7l	267-9l
Simple	12'-4"	13'-10"	17'-0"	19'-2"	21'-3"	23'-6"	24'-0"	25'-10"	27'-7"

Notes:

1. The maximum spans for vibration control, l_v , are increased by 10% as recommended by Nordic Structures.
2. The tabulated values apply to simply supported floor slabs.

Vibration, Double Span

Maximum span, l_v (ft)

Span	Layup								
	89-3s	105-3s	143-5s	175-5s	197-7s	213-7l	245-7s	245-7l	267-9l
Double	13'-5"	15'-1"	18'-7"	20'-11"	23'-2"	25'-8"	26'-2"	26'-3"	27'-7"

Notes:

1. The maximum spans for vibration control, l_v , are increased by 20% for non-structural elements that are considered to provide enhanced vibration effect.
2. If applicable, the concrete topping area density shall not be greater than twice the bare CLT floor area density.
3. The tabulated values apply to simply supported floor slabs.

Note:

1. The maximum spans for vibration control, l_v , are based on Clause A.8.5.3 of CSA O86:19.

Roof Slabs – Sizing

Snow load = 20 psf – Simple Span

Layup selection

Dead load ^(a) (psf)	L (ft) ^(b)														
	8	9	10	11	12	13	14	15	16	17	18	19	20	21	22
10					89-3s	89-3s	89-3s	89-3s	105-3s	105-3s		143-5s	143-5s	143-5s	143-5s
20				89-3s	89-3s		105-3s	105-3s			143-5s		143-5s	175-5s	175-5s
30				89-3s		105-3s	105-3s			143-5s		175-5s	175-5s	175-5s	
40	89-3s	89-3s	89-3s	89-3s		105-3s	105-3s			143-5s		175-5s	175-5s	175-5s	197-7s
50				105-3s	105-3s		143-5s	143-5s			175-5s		175-5s	197-7s	197-7s
60				105-3s	105-3s		143-5s	143-5s			175-5s		197-7s	197-7s	213-7l
70				105-3s	143-5s				175-5s	175-5s		175-5s	197-7s	197-7s	213-7l

Snow load = 20 psf – Double Span

Layup selection

Dead load ^(a) (psf)	L (ft) ^(b)														
	8	9	10	11	12	13	14	15	16	17	18	19	20	21	22
10					89-3s	89-3s	89-3s	89-3s	89-3s	89-3s	89-3s	89-3s	105-3s	105-3s	105-3s
20					89-3s	89-3s	89-3s	89-3s	89-3s	89-3s	89-3s	105-3s	105-3s	143-5s	143-5s
30					89-3s	89-3s	89-3s	89-3s	89-3s	89-3s	105-3s	105-3s	143-5s	143-5s	143-5s
40	89-3s	89-3s	89-3s	89-3s	89-3s		89-3s	89-3s		105-3s	105-3s	143-5s	143-5s	143-5s	143-5s
50					89-3s		89-3s	89-3s		105-3s	143-5s	143-5s	143-5s	143-5s	175-5s
60					89-3s		89-3s	105-3s		143-5s	143-5s	143-5s	143-5s	175-5s	175-5s
70				89-3s			105-3s	105-3s	143-5s	143-5s	143-5s	143-5s	143-5s	175-5s	175-5s

- a) The panel self weight is considered and shall not be included in the dead load.
- b) Span is measured center to center of supports.

Notes:

1. For preliminary design use only. Final design shall include a complete analysis including the verification of the bearing capacity. If applicable, the final design shall include a consideration for vibration control and the verification of a concentrated live load as defined in IBC 1607.4.
2. Tables are based on uniform loads, dry service conditions, and a load duration factor, C_D , of 1.15, for bending in the major strength direction of the panel.
3. Tabulated values take into account the bending moment and shear capacities, a live load deflection limit of $L/240$, a total load deflection limit of $L/180$.
4. Fire resistance-rating takes into account the bending moment and shear capacities of the reduced cross-section.
5. Fire resistance-rating:

30 min	60 min	90 min	120 min
--------	--------	--------	---------

Snow load = 40 psf – Simple Span

Layup selection

Dead load ^(a) (psf)	L (ft) ^(b)														
	8	9	10	11	12	13	14	15	16	17	18	19	20	21	22
10	89-3s	89-3s	89-3s	89-3s	89-3s	89-3s	105-3s	105-3s	143-5s	143-5s	143-5s	143-5s	143-5s	175-5s	175-5s
20					89-3s	105-3s	105-3s	175-5s			175-5s	197-7s			
30					89-3s	105-3s	143-5s	175-5s			197-7s	213-7l			
40					105-3s	143-5s	175-5s	197-7s			213-7l	213-7l			
50					105-3s	143-5s	175-5s	197-7s			213-7l	213-7l			
60					105-3s	143-5s	175-5s	197-7s			213-7l	213-7l			
70					105-3s	143-5s	175-5s	197-7s			213-7l	213-7l			

Snow load = 40 psf – Double Span

Layup selection

Dead load ^(a) (psf)	L (ft) ^(b)																	
	8	9	10	11	12	13	14	15	16	17	18	19	20	21	22			
10	89-3s	89-3s	89-3s	89-3s	89-3s	89-3s	89-3s	89-3s	89-3s	89-3s	105-3s	105-3s	143-5s	143-5s	143-5s			
20					89-3s	89-3s	89-3s	89-3s	89-3s	105-3s	105-3s	143-5s	143-5s	143-5s	143-5s			
30					89-3s	89-3s	89-3s	89-3s	89-3s	105-3s	105-3s	143-5s	143-5s	143-5s	143-5s	143-5s		
40					89-3s	89-3s	89-3s	89-3s	89-3s	105-3s	105-3s	143-5s	143-5s	143-5s	143-5s	143-5s	143-5s	
50					89-3s	89-3s	89-3s	89-3s	89-3s	105-3s	105-3s	143-5s	143-5s	143-5s	143-5s	143-5s	143-5s	143-5s
60					89-3s	89-3s	89-3s	89-3s	89-3s	105-3s	105-3s	143-5s	143-5s	143-5s	143-5s	143-5s	143-5s	143-5s
70					89-3s	89-3s	89-3s	89-3s	89-3s	105-3s	105-3s	143-5s	143-5s	143-5s	143-5s	143-5s	143-5s	143-5s

- a) The panel self weight is considered and shall not be included in the dead load.
- b) Span is measured center to center of supports.

Notes:

1. For preliminary design use only. Final design shall include a complete analysis including the verification of the bearing capacity. If applicable, the final design shall include a consideration for vibration control and the verification of a concentrated live load as defined in IBC 1607.4.
2. Tables are based on uniform loads, dry service conditions, and a load duration factor, C_D , of 1.15, for bending in the major strength direction of the panel.
3. Tabulated values take into account the bending moment and shear capacities, a live load deflection limit of $L/240$, a total load deflection limit of $L/180$.
4. Fire resistance-rating takes into account the bending moment and shear capacities of the reduced cross-section.
5. Fire resistance-rating:

30 min	60 min	90 min	120 min
--------	--------	--------	---------

Snow load = 60 psf – Simple Span

Layup selection

Dead load ^(a) (psf)	L (ft) ^(b)														
	8	9	10	11	12	13	14	15	16	17	18	19	20	21	22
10				89-3s	89-3s	105-3s	105-3s			143-5s	143-5s	175-5s	175-5s	175-5s	197-7s
20			89-3s	89-3s	105-3s			143-5s	143-5s		175-5s	175-5s	197-7s	197-7s	197-7s
30			89-3s	89-3s	105-3s			143-5s	143-5s		175-5s	175-5s	197-7s	197-7s	197-7s
40	89-3s	89-3s		89-3s	105-3s			143-5s	143-5s		175-5s	175-5s	197-7s	197-7s	197-7s
50			89-3s	89-3s	105-3s			143-5s	143-5s		175-5s	175-5s	197-7s	197-7s	197-7s
60			105-3s	105-3s	143-5s			143-5s	143-5s		175-5s	175-5s	197-7s	197-7s	197-7s
70			105-3s	143-5s	143-5s			175-5s	175-5s		197-7s	197-7s	213-7l	213-7l	245-7s

Snow load = 60 psf – Double Span

Layup selection

Dead load ^(a) (psf)	L (ft) ^(b)														
	8	9	10	11	12	13	14	15	16	17	18	19	20	21	22
10				89-3s	89-3s			89-3s		105-3s	105-3s	143-5s	143-5s	143-5s	143-5s
20				89-3s	89-3s			89-3s		105-3s	105-3s	143-5s	143-5s	143-5s	143-5s
30			89-3s			89-3s			105-3s		143-5s	143-5s	143-5s	143-5s	143-5s
40	89-3s	89-3s			89-3s				105-3s		143-5s	143-5s	143-5s	143-5s	143-5s
50				89-3s	89-3s				105-3s		143-5s	143-5s	143-5s	143-5s	143-5s
60			89-3s			105-3s			105-3s		143-5s	143-5s	143-5s	143-5s	143-5s
70						105-3s			143-5s	143-5s	143-5s	143-5s	175-5s	175-5s	197-7s

- a) The panel self weight is considered and shall not be included in the dead load.
- b) Span is measured center to center of supports.

Notes:

1. For preliminary design use only. Final design shall include a complete analysis including the verification of the bearing capacity. If applicable, the final design shall include a consideration for vibration control and the verification of a concentrated live load as defined in IBC 1607.4.
2. Tables are based on uniform loads, dry service conditions, and a load duration factor, C_D , of 1.15, for bending in the major strength direction of the panel.
3. Tabulated values take into account the bending moment and shear capacities, a live load deflection limit of $L/240$, a total load deflection limit of $L/180$.
4. Fire-resistance rating takes into account the bending moment and shear capacities of the reduced cross-section.
5. Fire-resistance rating:

30 min	60 min	90 min	120 min
--------	--------	--------	---------

Roof Slabs – Selection Tables

Bending Moment and Shear Capacities

Allowable uniform total load (psf)

L ^(a) (ft)	Layup								
	89-3s	105-3s	143-5s	175-5s	197-7s	213-7l	245-7s	245-7l	267-9l
10.0	211	252							
10.5	201	240							
11.0	191	228							
11.5	183	218							
12.0	175	208	289						
12.5	168	199	276						
13.0	161	191	265						
13.5	155	184	255						
14.0	149	177	245						
14.5	144	171	236	292					
15.0	137	165	228	282					
15.5	128	159	220	272					
16.0	120	154	213	263	299				
16.5	113	149	206	255	290				
17.0	107	144	200	247	281				
17.5	101	136	194	239	272	295			
18.0	95	128	188	232	264	287			
18.5	90	122	183	226	256	278			
19.0	85	115	178	219	249	271			
19.5	81	109	173	214	243	263			
20.0	77	104	169	208	236	256	297	297	
20.5	73	99	164	203	230	250	289	289	
21.0	70	94	160	198	224	243	282	282	
21.5	67	90	154	193	219	237	275	275	
22.0	64	86	147	188	214	232	268	268	293
22.5	61	82	140	184	209	226	262	262	286
23.0	58	79	134	180	204	221	256	256	280
23.5	56	75	129	173	199	216	250	250	273
24.0	54	72	123	166	195	212	245	245	267
24.5	51	69	118	159	191	207	239	239	261
25.0		67	114	153	187	203	234	234	256
25.5		64	109	147	183	198	230	230	251

Bending moment and shear capacities
• $M_0 \geq M$ and $V_0 \geq V$

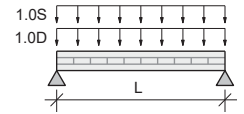
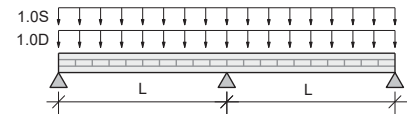

a) Span is measured center to center of supports.

Notes:

1. For preliminary design use only. Final design shall include a complete analysis including the verification of the bending moment, shear, and bearing capacities and a consideration for snow load and total load deflections. If applicable, the final design shall include a consideration for vibration control, the verification of a concentrated live load as defined in IBC 1607.4, and fire-resistance requirements.
2. Tables are based on dry service conditions, a load duration factor, C_D , of 1.15, and the most restrictive of simple span or double span, for bending in the major strength direction of the panel.

L/180 Deflection Limit – Simple Span

Allowable uniform total load (psf)

L ^(a) (ft)	Layout								
	89-3s	105-3s	143-5s	175-5s	197-7s	213-7l	245-7s	245-7l	267-9l
10.0	127	189							
10.5	111	166	379						
11.0	97	146	335						
11.5	86	130	297						
12.0	76	115	264	397					
12.5	68	103	236	357					
13.0	60	92	212	323					
13.5	54	83	191	292					
14.0		75	173	265	395				
14.5		68	156	241	360				
15.0		62	142	220	328				
15.5		56	130	201	300				
16.0		51	118	185	275	391			
16.5			109	170	253	360	390		
17.0			100	156	233	332	360		
17.5			92	144	215	307	334		
18.0			85	133	199	284	309	381	
18.5			78	123	184	263	287	355	
19.0			72	115	171	245	268	331	
19.5			67	106	159	228	249	309	
20.0			62	99	148	212	233	289	382
20.5			58	92	138	198	217	270	358
21.0			54	86	129	185	204	253	335
21.5			51	81	120	173	191	238	314
22.0				76	113	162	179	223	295
22.5				71	106	152	168	210	277
23.0				67	99	143	158	198	261
23.5				63	93	135	149	187	246
24.0				59	88	127	140	176	232
24.5				56	83	120	133	166	219
25.0				52	78	113	125	157	207
25.5					74	107	118	149	196

Deflection limit
 • $K_{cr} \Delta_{LT} + \Delta_{ST} \leq L/180$

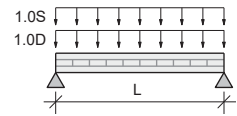

a) Span is measured center to center of supports.

Notes:

1. For preliminary design use only. Final design shall include a complete analysis including the verification of the bending moment, shear, and bearing capacities and a consideration for snow load and total load deflections. If applicable, the final design shall include a consideration for vibration control, the verification of a concentrated live load as defined in IBC 1607.4, and fire-resistance requirements.
2. Tables are based on dry service conditions, for bending in the major strength direction of the panel.
3. The above values apply to slabs with a dead load less or equal to the snow load. If the dead load is greater than the snow load, multiply the allowable uniform total load by the corresponding adjustment factor:

Adjustment factor based on dead load / snow load ratio (D/S)

D/S	1.00	1.25	1.50	1.75	2.00	2.25	2.50	2.75	3.00
Factor	1.000	0.964	0.938	0.917	0.900	0.886	0.875	0.865	0.857

L/180 Deflection Limit – Double Span

Allowable uniform total load (psf)

L ^(a) (ft)	Layup								
	89-3s	105-3s	143-5s	175-5s	197-7s	213-7l	245-7s	245-7l	267-9l
10.0	245	344							
10.5	216	306							
11.0	191	273							
11.5	169	244							
12.0	151	219							
12.5	135	198							
13.0	122	179							
13.5	110	162	368						
14.0	99	147	335						
14.5	90	134	305						
15.0	82	122	279						
15.5	75	112	256	377					
16.0	68	103	235	348					
16.5	63	95	216	322					
17.0	58	87	199	298					
17.5	53	80	184	277					
18.0		74	171	257	385				
18.5		69	158	240	358				
19.0		64	147	224	334				
19.5		60	137	209	312				
20.0		55	127	195	291				
20.5		52	119	183	273	384			
21.0			111	171	256	360	386		
21.5			104	161	240	339	364		
22.0			98	151	225	319	343		
22.5			92	142	212	300	324	394	
23.0			86	134	200	283	306	373	
23.5			81	126	188	267	289	353	
24.0			76	119	178	253	274	335	
24.5			72	113	168	239	259	317	
25.0			68	106	159	226	246	301	
25.5			64	101	150	214	233	286	380

Deflection limit
• $K_{cr} \Delta_{LT} + \Delta_{ST} \leq L/180$

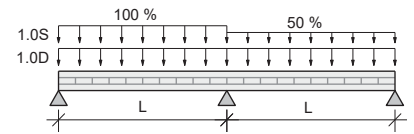

a) Span is measured center to center of supports.

Notes:

1. For preliminary design use only. Final design shall include a complete analysis including the verification of the bending moment, shear, and bearing capacities and a consideration for snow load and total load deflections. If applicable, the final design shall include a consideration for vibration control, the verification of a concentrated live load as defined in IBC 1607.4, and fire-resistance requirements.
2. Tables are based on dry service conditions, for bending in the major strength direction of the panel.
3. The above values apply to slabs with a dead load less or equal to the snow load. If the dead load is greater than the snow load, multiply the allowable uniform total load by the corresponding adjustment factor:

Adjustment factor based on dead load / snow load ratio (D/S)

D/S	1.00	1.25	1.50	1.75	2.00	2.25	2.50	2.75	3.00
Factor	1.000	0.964	0.938	0.917	0.900	0.886	0.875	0.865	0.857

L/240 Deflection Limit – Simple Span

Allowable uniform snow load (psf)

L ^(a) (ft)	Layup								
	89-3s	105-3s	143-5s	175-5s	197-7s	213-7l	245-7s	245-7l	267-9l
10.0	143	213							
10.5	125	187							
11.0	109	165							
11.5	96	146	334						
12.0	85	130	297						
12.5	76	116	266						
13.0	68	104	239						
13.5	61	94	215	328					
14.0	55	85	194	298					
14.5	50	77	176	271					
15.0	45	70	160	248					
15.5	41	63	146	226	338				
16.0		58	133	208	310				
16.5		53	122	191	284				
17.0		49	112	176	262				
17.5		45	103	162	242	345			
18.0		41	95	150	223	319	348		
18.5			88	139	207	296	323		
19.0			81	129	192	275	301		
19.5			76	120	178	256	280	347	
20.0			70	112	166	239	262	325	
20.5			65	104	155	223	245	304	
21.0			61	97	145	208	229	285	
21.5			57	91	135	195	215	268	
22.0			53	85	127	183	201	251	332
22.5			50	80	119	172	189	236	312
23.0			47	75	112	161	178	223	294
23.5			44	70	105	152	168	210	277
24.0			41	66	99	143	158	198	261
24.5				63	93	135	149	187	247
25.0				59	88	127	141	177	233
25.5				56	83	120	133	167	221

Deflection limit
 • $\Delta_s \leq L/240$

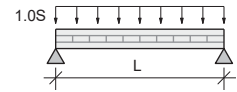

a) Span is measured center to center of supports.

Notes:

1. For preliminary design use only. Final design shall include a complete analysis including the verification of the bending moment, shear, and bearing capacities and a consideration for snow load and total load deflections. If applicable, the final design shall include a consideration for vibration control, the verification of a concentrated live load as defined in IBC 1607.4, and fire-resistance requirements.
2. Tables are based on dry service conditions, for bending in the major strength direction of the panel.

L/240 Deflection Limit – Double Span

Allowable uniform snow load (psf)

L ^(a) (ft)	Layup								
	89-3s	105-3s	143-5s	175-5s	197-7s	213-7l	245-7s	245-7l	267-9l
10.0	237	338							
10.5	208	299							
11.0	183	266							
11.5	163	238							
12.0	145	213							
12.5	129	191							
13.0	116	172							
13.5	104	156							
14.0	94	141	323						
14.5	85	129	294						
15.0	78	117	268						
15.5	71	107	245						
16.0	65	98	225	338					
16.5	59	90	207	312					
17.0	54	83	191	289					
17.5	50	77	176	268					
18.0	46	71	163	249					
18.5	43	66	151	231	345				
19.0		61	140	215	321				
19.5		57	130	201	299				
20.0		53	121	187	279				
20.5		49	113	175	261				
21.0		46	105	164	245	347			
21.5		43	99	154	229	326			
22.0			92	144	215	306	332		
22.5			87	136	202	288	313		
23.0			81	128	190	272	295		
23.5			77	120	179	256	279	343	
24.0			72	113	169	242	263	324	
24.5			68	107	160	228	249	307	
25.0			64	101	151	216	236	292	
25.5			61	96	143	205	224	277	

Deflection limit
• $\Delta_s \leq L/240$

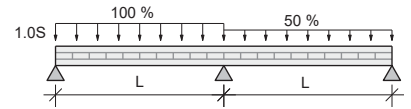

a) Span is measured center to center of supports.

Notes:

1. For preliminary design use only. Final design shall include a complete analysis including the verification of the bending moment, shear, and bearing capacities and a consideration for snow load and total load deflections. If applicable, the final design shall include a consideration for vibration control, the verification of a concentrated live load as defined in IBC 1607.4, and fire-resistance requirements.
2. Tables are based on dry service conditions, for bending in the major strength direction of the panel.

Walls – Design Properties

Walls – Design Properties

CLT stress grade	E1 (L = S-P-F 1950f MSR and T = S-P-F No. 3)								
Layup	89-3s	105-3s	143-5s	175-5s	197-7s	213-7l	245-7s	245-7l	267-9l
Loading parallel to outermost layers									
Compression in the major strength direction									
Compressive capacity, P_0 (10^3 lbf/ft) ^(a)	59	59	89	89	119	149	119	149	178
Effective cross-sectional area, $A_{\text{eff},0}$ ($\text{in.}^2/\text{ft}$)	33	33	50	50	66	83	66	83	99
Effective out-of-plane moment of inertia, $I_{\text{eff},0}$ ($\text{in.}^4/\text{ft}$)	42	68	157	257	383	566	634	824	1,075
Effective out-of-plane radius of gyration, $r_{\text{eff},0}$ ($\text{in.}/\text{ft}$) ^(b)	1.1	1.4	1.8	2.3	2.4	2.6	3.1	3.2	3.3
Bending in the major strength direction									
Effective flatwise bending moment capacity, $M_{\text{eff},f,0}$ (lbf-ft/ft) ^(c)	3,350	4,525	7,725	10,400	13,725	18,700	18,375	23,700	28,325
Flatwise shear capacity, $V_{s,0}$ (lbf/ft)	1,260	1,490	2,030	2,480	2,800	3,025	3,475	3,475	3,775
Effective flatwise bending stiffness, $(EI)_{\text{eff},f,0}$ (10^6 lbf-in. ² /ft)	72	115	267	440	654	963	1,089	1,404	1,831
Effective shear stiffness in flatwise bending, $(GA)_{\text{eff},f,0}$ (10^6 lbf/ft)	0.48	0.46	0.96	0.92	1.4	1.6	1.4	1.4	2.0
Loading perpendicular to outermost layers									
Compression in the minor strength direction									
Compressive capacity, P_{90} (10^3 lbf/ft) ^(a)	5.9	11	12	21	18	12	32	21	18
Effective cross-sectional area, $A_{\text{eff},90}$ ($\text{in.}^2/\text{ft}$)	9.0	17	18	33	27	18	50	33	27
Effective out-of-plane moment of inertia, $I_{\text{eff},90}$ ($\text{in.}^4/\text{ft}$)	0.42	2.6	21	68	83	21	257	68	83
Effective out-of-plane radius of gyration, $r_{\text{eff},90}$ ($\text{in.}/\text{ft}$) ^(b)	0.22	0.40	1.1	1.4	1.7	1.1	2.3	1.4	1.7
Bending in the minor strength direction									
Effective flatwise bending moment capacity, $M_{\text{eff},f,90}$ (lbf-ft/ft) ^(c)	45	160	615	1,370	1,410	615	3,150	1,370	1,410
Flatwise shear capacity, $V_{s,90}$ (lbf/ft)	270	495	1,040	1,490	1,800	1,040	2,480	1,490	1,800
Effective flatwise bending stiffness, $(EI)_{\text{eff},f,90}$ (10^6 lbf-in. ² /ft)	0.51	3.1	26	81	101	26	313	81	101
Effective shear stiffness in flatwise bending, $(GA)_{\text{eff},f,90}$ (10^6 lbf/ft)	0.39	0.61	0.78	1.2	1.2	0.93	1.8	1.3	1.3

a) The compressive capacity under axial load, P_0 and P_{90} , shall be adjusted by the column stability factor, C_p , as defined in the NDS. The effective flatwise bending stiffness, $(EI)_{\text{eff},f}$, values shall be based on S-P-F 1950f MSR lumber ($E = 1,700,000$ psi) and on $I_{\text{eff},0}$ for loading parallel to outermost layers, or on S-P-F No. 3 lumber ($E = 1,200,000$ psi) and on $I_{\text{eff},90}$ for loading perpendicular to outermost layers. The critical buckling design value, F_{cE} , shall be calculated as follows:

$$F_{cE} = \pi^2 (EI)_{\text{app-min}} / (\ell_e)^2 A_{\text{eff}}$$

- b) As per NDS 3.7.1.4, the slenderness ratio for walls, $\ell_e / (\sqrt{12} r_{\text{eff}})$, shall not exceed 50, except that during construction $\ell_e / (\sqrt{12} r_{\text{eff}})$ shall not exceed 75.
 c) The effective flatwise bending moment capacity values in the major strength direction, $M_{\text{eff},f,0}$, include the adjustment factor of 0.85 from ANSI/APA PRG 320.

Notes:

- The tabulated design values are for dry service conditions and normal duration of loading.
- The compressive capacity perpendicular to grain values shall be based on S-P-F No. 3 lumber ($f_{cp} = 425$ psi).
- The specific gravity for dowel-type fastener design is 0.42.
- The density for member weight is 32 pcf for a moisture content of 12%.
- Design of CLT members shall be in accordance with the NDS.

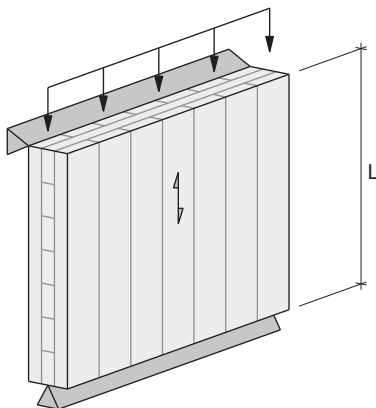

Loading parallel to outermost layers

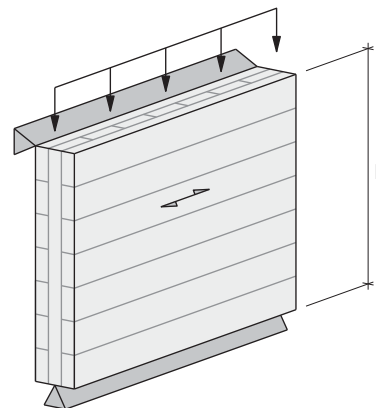

Loading perpendicular to outermost layers

Shear Walls, Lintels, and Diaphragms – Design Properties

Shear Walls, Lintels, and Diaphragms – Design Properties

CLT stress grade	E1 (L = S-P-F 1950f MSR and T = S-P-F No. 3)								
Layup	89-3s	105-3s	143-5s	175-5s	197-7s	213-7l	245-7s	245-7l	267-9l
Loading parallel to outermost layers									
Edgewise bending in the minor strength direction									
Effective width in edgewise bending, $b_{\text{eff},e,90}$ (in.) ^(a)	0.75	1.38	1.50	2.75	2.25	1.50	4.13	2.75	2.25
Reference edgewise shear design value, $F_{v,e,90}$ (psi) ^(b)	190	190	215	215	215	215	215	215	215
Edgewise shear rigidity, $G_{e,90}t_p$ (10^6 lbf/ft) ^(c)	1.52	1.79	2.44	2.99	3.37	3.64	4.18	4.18	4.56
Loading perpendicular to outermost layers									
Edgewise bending in the major strength direction									
Effective width in edgewise bending, $b_{\text{eff},e,0}$ (in.) ^(a)	2.75	2.75	4.13	4.13	5.50	6.88	5.50	6.88	8.25
Reference edgewise shear design value, $F_{v,e,0}$ (psi) ^(b)	155	155	185	185	155	185	185	185	155
Edgewise shear rigidity, $G_{e,0}t_p$ (10^6 lbf/ft) ^(c)	1.52	1.79	2.44	2.99	3.37	3.64	4.18	4.18	4.56

- a) The edgewise bending moment capacity, M_e , and the effective edgewise bending stiffness, $(EI)_{\text{eff},e}$, values shall be based on the effective width in edgewise bending and depth of the panel, $b_{\text{eff},e}$ and d (see table above and figures below), respectively. Calculations shall be based on S-P-F No. 3 lumber ($F_b = 500$ psi, $E = 1,200,000$ psi) for loading parallel to outermost layer, or on S-P-F 1950f MSR lumber ($F_b = 1,950$ psi, $E = 1,700,000$ psi) for loading perpendicular to outermost layer.
- b) The edgewise shear capacity values, V_e , shall be based on the gross cross-sectional area of the panel.
- c) $G_{e,0}$ and $G_{e,90} = 36,200$ psi based on product performance testing. Edgewise shear rigidity, $(GA)_{\text{eff},e}$, shall be calculated by multiplying G_{e,t_p} by the member depth, d , in feet (see figures below).

Notes:

- The tabulated design values are for dry service conditions and normal duration of loading.
- The compressive capacity perpendicular to grain values shall be based on S-P-F No. 3 lumber ($f_{cp} = 425$ psi).
- The specific gravity for dowel-type fastener design is 0.42.
- The density for member weight is 32 pcf for a moisture content of 12%.
- Design of CLT members shall be in accordance with the NDS.

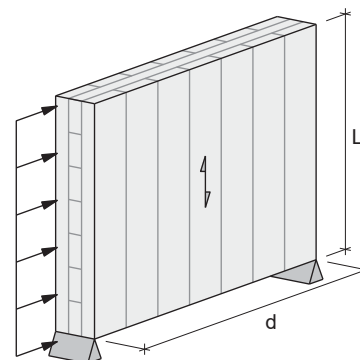
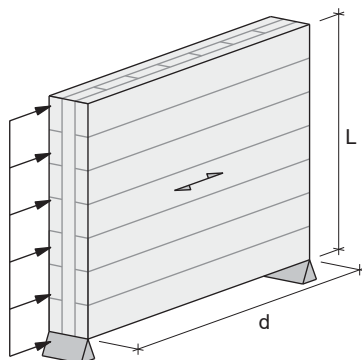
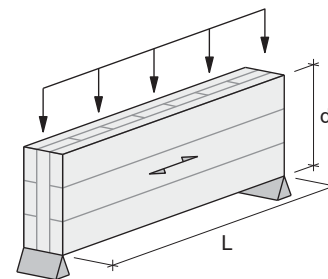
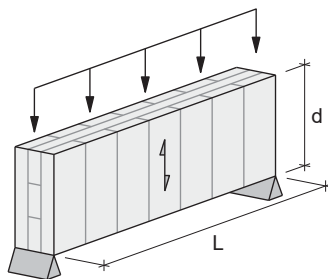

Loading parallel to outermost layers

Loading perpendicular to outermost layers

NORDIC

TECHNICAL GUIDE
NORDIC X-LAM

NS-GT6 

ASD

VERSION
2026-02-01

STRUCTURAL
DETAILS

3



GENERAL NOTES

1.0 General

- 1.1 This document supersedes all previous versions. For the latest version, consult nordic.ca or contact Nordic Structures.
- 1.2 The information contained in this document is provided for information purposes only. This information should not be used for any application without examination and verification of its accuracy, suitability and applicability by a licensed engineer, architect or other professional. Nordic Structures does not guarantee that the information is suitable for any general or particular use, and assumes no responsibility for the use, application of and/or reference to the information.
- 1.3 All dimensions are in inches (in.), unless otherwise noted.
- 1.4 For more information, consult nordic.ca or contact Nordic Structures.

2.0 Design of connections

- 2.1 The design of connections, including fire resistance if required, shall be in accordance with the National Design Specification (NDS) for Wood Construction 2015.
- 2.2 The design of connections should include considerations for structural and service performance, such as resistance, minimum distances, dimensional changes, durability, erection and fire safety, among others, as well as taking into account architectural requirements.
- 2.3 The connections shown in this document are provided for information purposes only, and conceptually. Note that many possibilities and variants are possible.

Structure, GL-CLT

Continuous Floor Slab on Beam

NS-DS2001

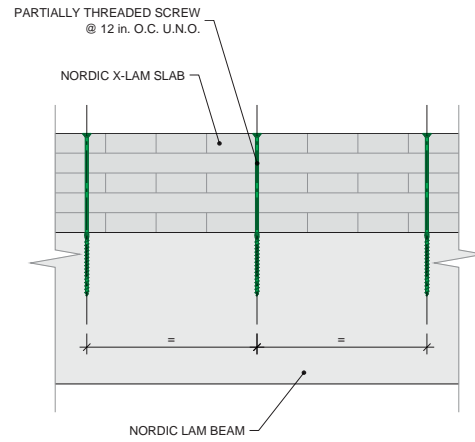
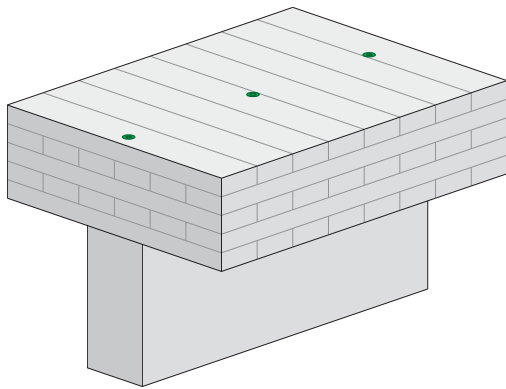

Structure, GL-CLT

Single Floor Slab on Beam

NS-DS2002

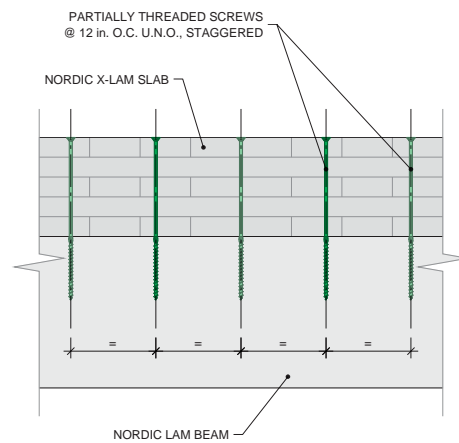
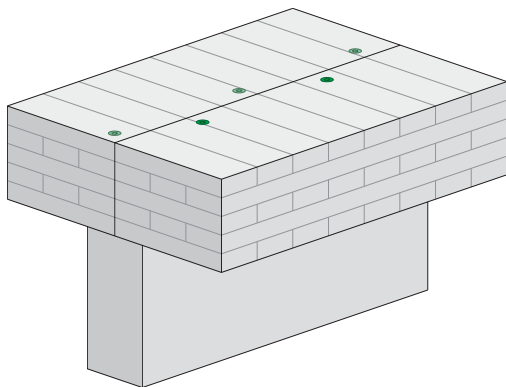

Structure, GL-CLT

Face-mount Hanger

NS-DS2003

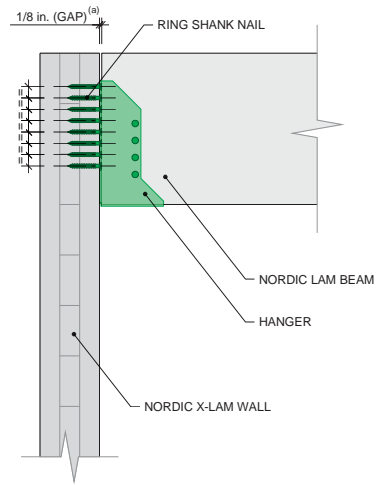
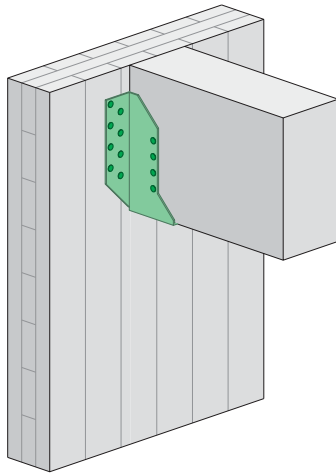

a) The 1/8 in. gap may not be required depending on the detail on the other side of the beam.

Structure, GL-CLT

Face-mount Hanger with Concealed Flanges

NS-DS2067

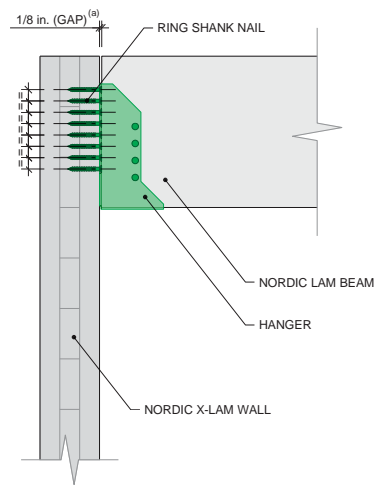
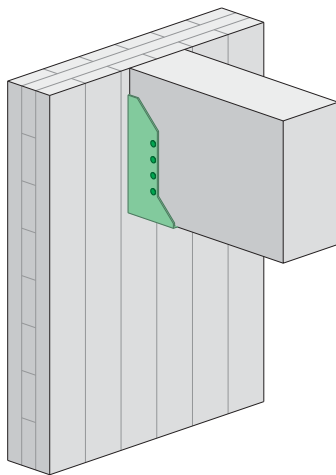

a) The 1/8 in. gap may not be required depending on the detail on the other side of the beam.

Structure, GL-CLT

Knife Plate

NS-DS2004

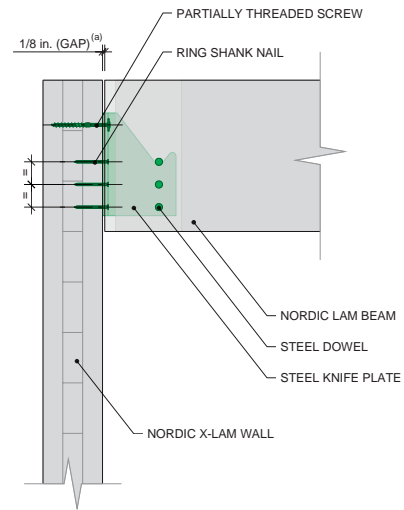
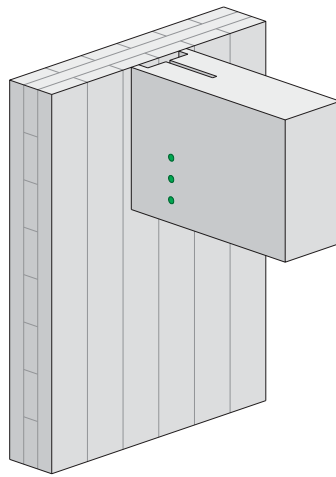

a) The 1/8 in. gap may not be required depending on the detail on the other side of the beam.

Structure, GL-CLT

Knife Plate with Cap

NS-DS2005

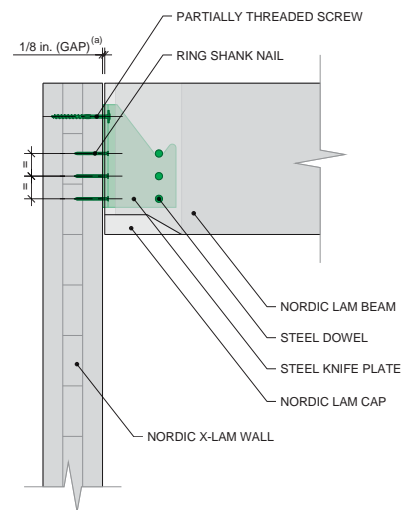
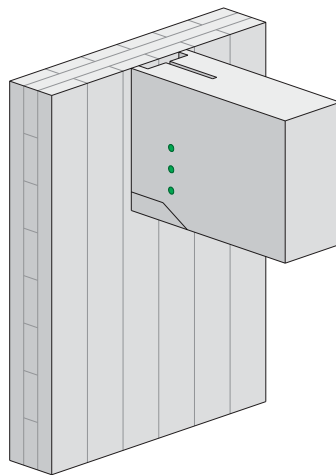

a) The 1/8 in. gap may not be required depending on the detail on the other side of the beam.

Structure, GL-CLT

Screwed Beam to Column

NS-DS2006

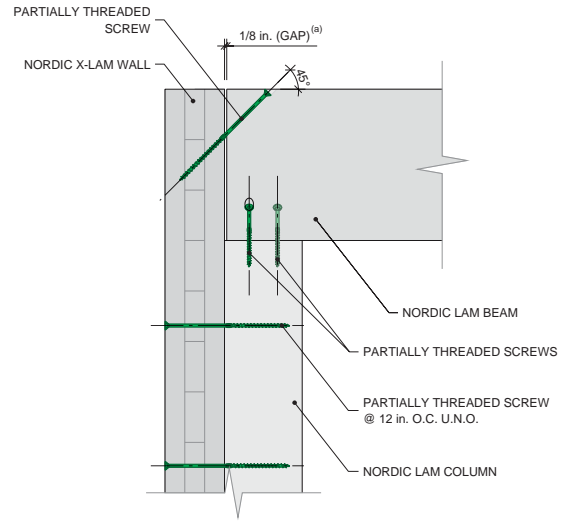
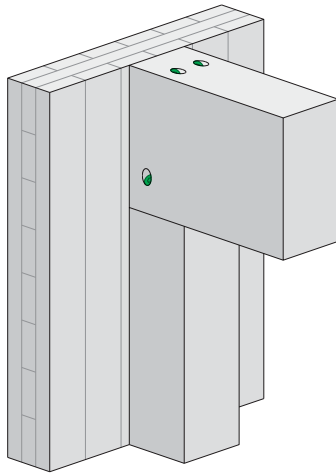

a) The 1/8 in. gap may not be required depending on the detail on the other side of the beam.

Structure, GL-CLT

Beam to Column with Knife Plate

NS-DS2007

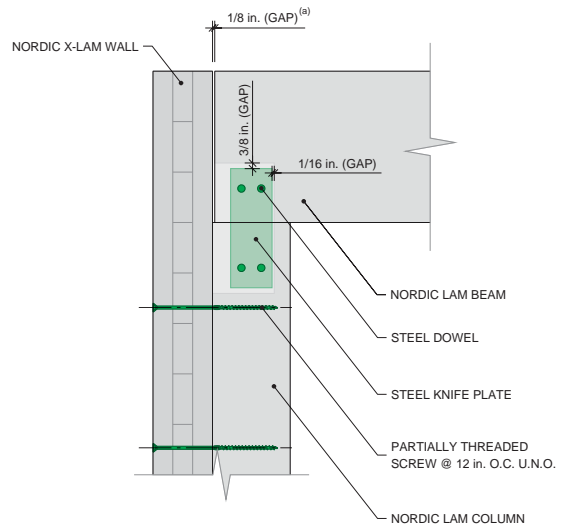
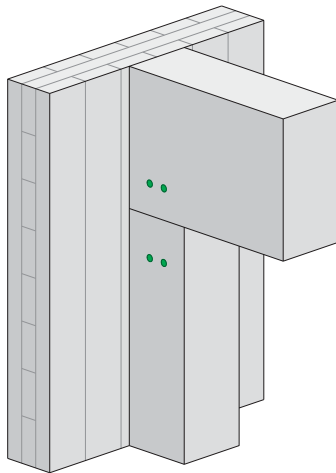

a) The 1/8 in. gap may not be required depending on the detail on the other side of the beam.

Structure, GL-CLT

Pocket for Beam

NS-DS2008

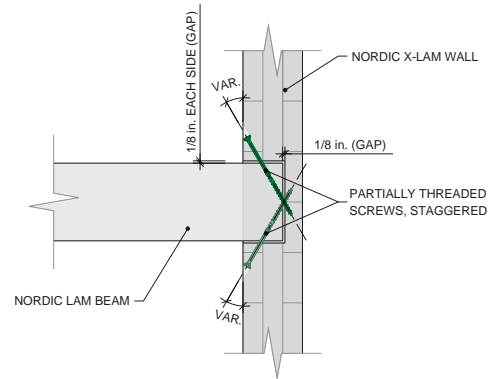
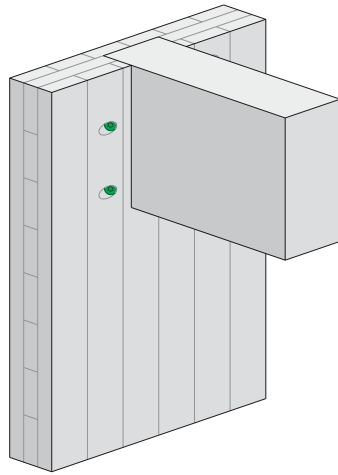

Structure, GL-CLT

Through Pocket for Beam

NS-DS2009

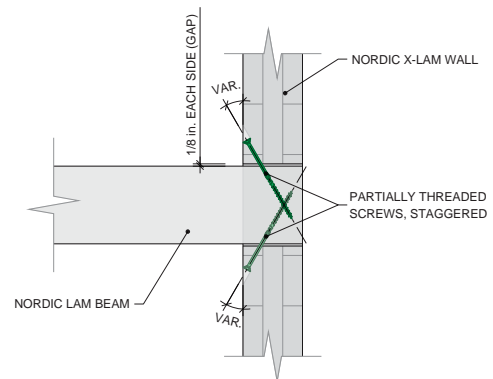
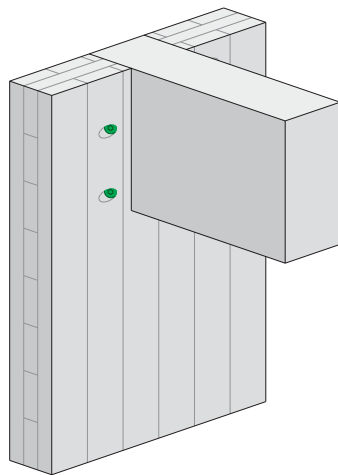

Structure, Wall-Foundation

Wall to Sill Plate, Screws

NS-DS2010

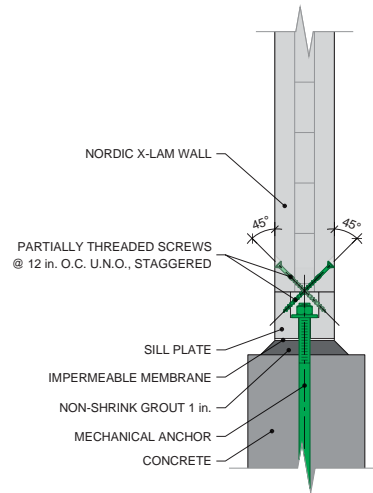
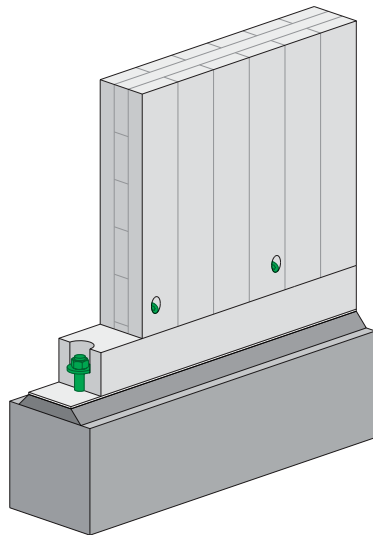

Structure, Wall-Foundation

Wall to Sill Plate, Nailed Steel Plate

NS-DS2011

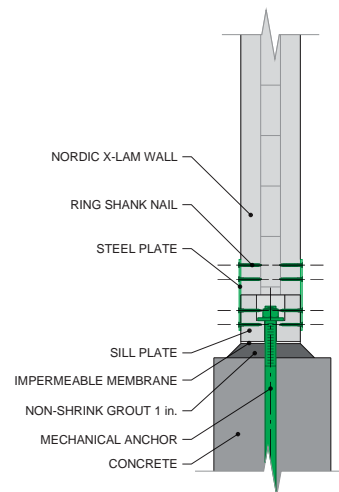
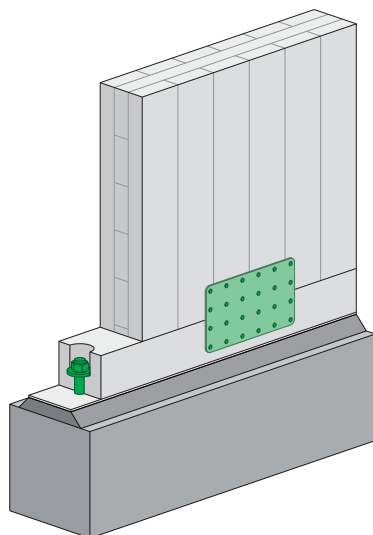

Structure, Wall-Foundation

Wall to Sill Plate, Holdown

NS-DS2012

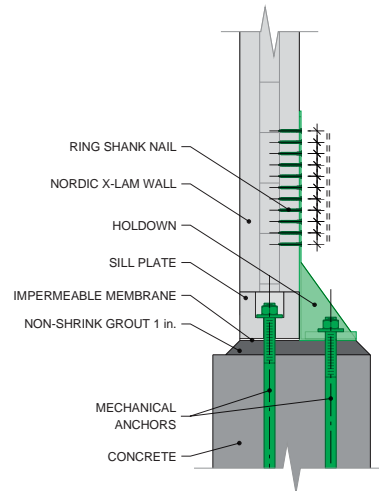
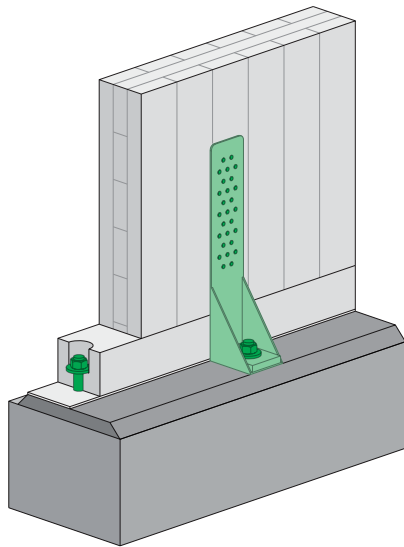

Structure, Wall-Foundation

Wall to Sill Plate, Steel Angle

NS-DS2013

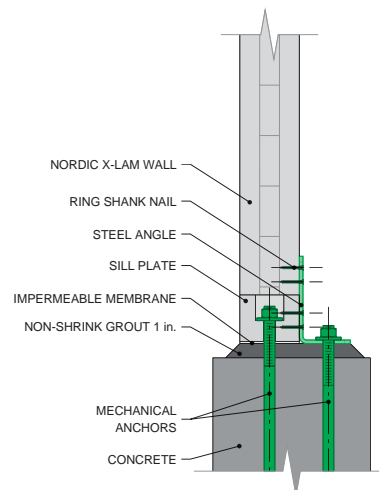
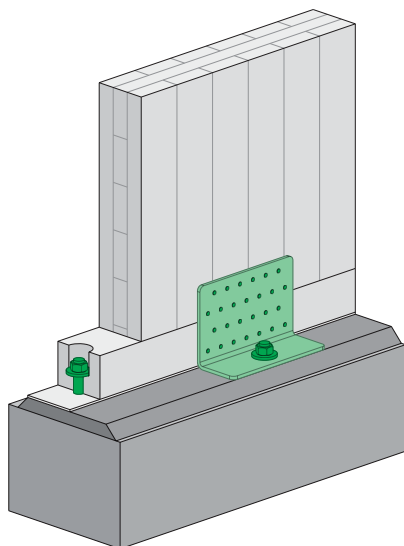

Structure, Wall-Foundation

Wall to Foundation, Holdown

NS-DS2014

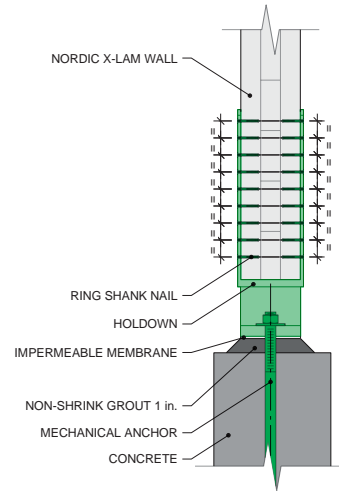
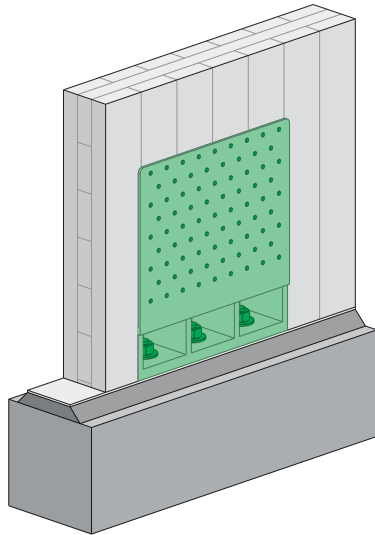

Structure, Wall-Foundation

Wall to Foundation, Nailed Steel Angle

NS-DS2015

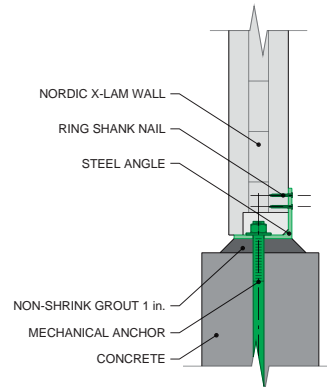
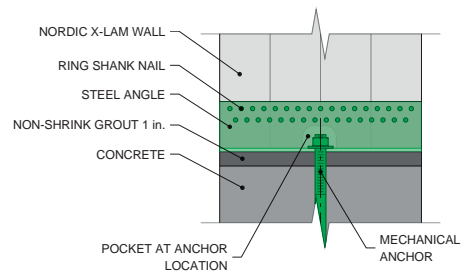
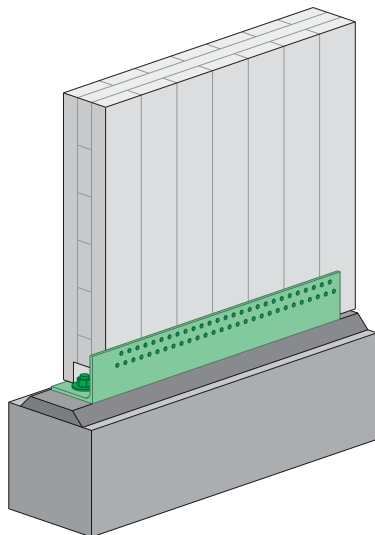

Structure, Wall-Foundation

Wall to Foundation, Screwed Steel Angle

NS-DS2016

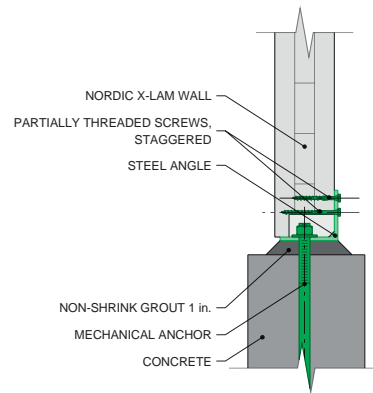
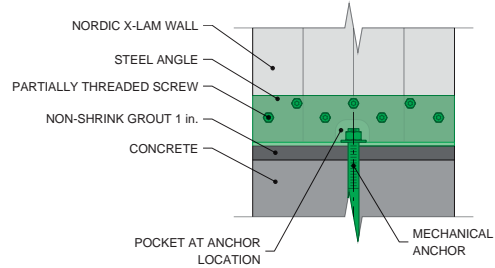
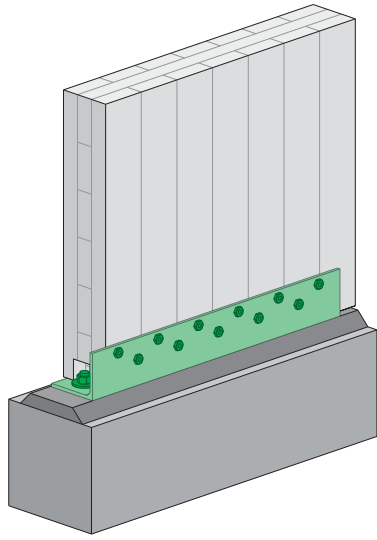

Note:
 1. This assembly detail offers a resistance to forces acting perpendicularly to the foundation wall.

Structure, Wall-Foundation

Wall to Foundation, Nailed Steel Angle and Steel C Shape

NS-DS2068

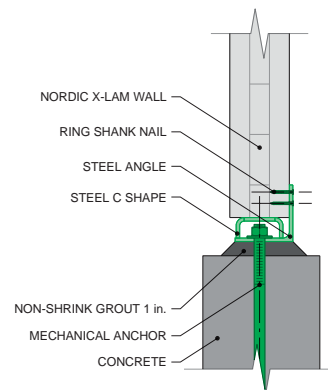
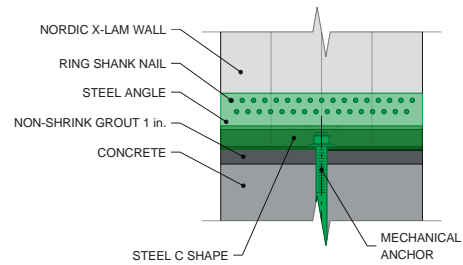
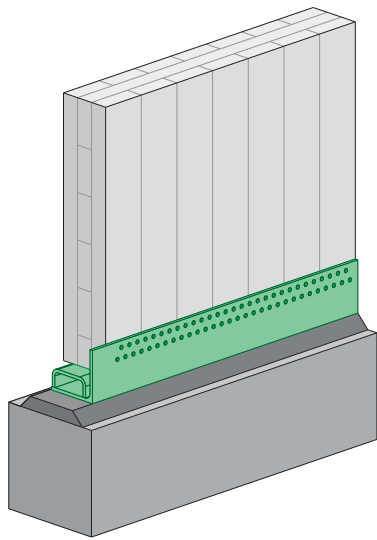

Structure, Wall-Foundation

Wall to Foundation, Nailed C Shape

NS-DS2017

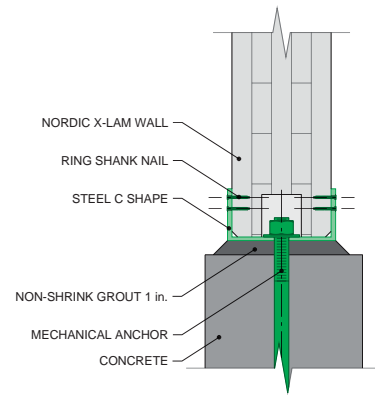
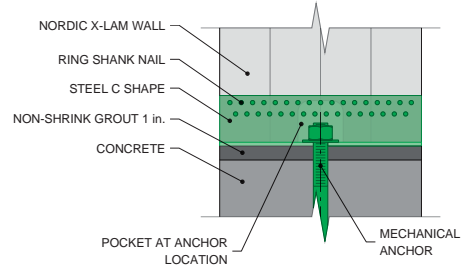
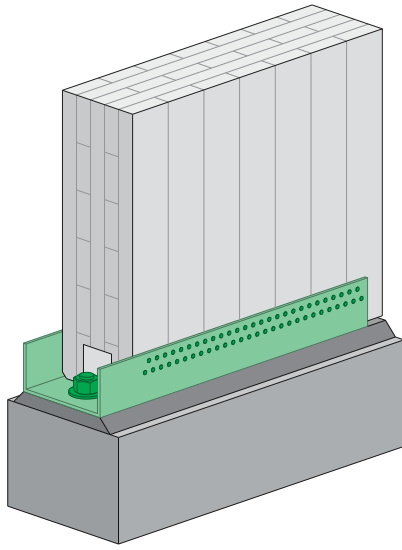

Note:
1. For an exterior wall on foundation, careful consideration should be given to waterproofing and drainage at the junction between wall and steel C shape.

Structure, Floor/Roof-Wall

Ledger

NS-DS2018

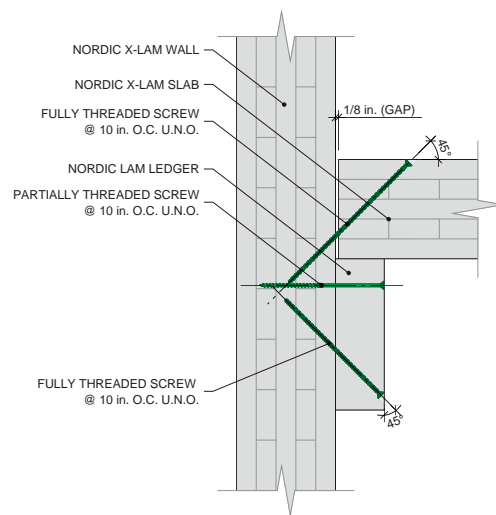
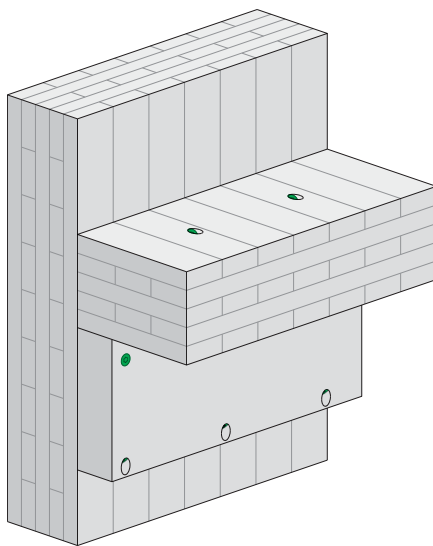

Structure, Floor/Roof-Wall

Steel Angle

NS-DS2019

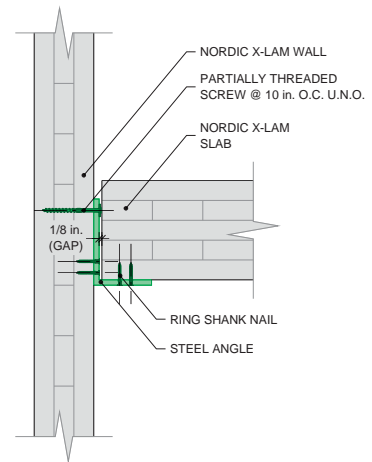
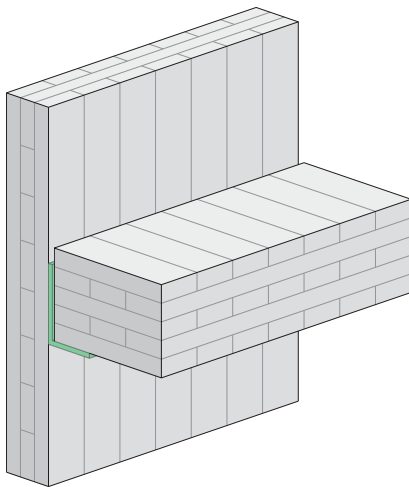

Structure, Floor/Roof-Wall

Screwed Floor/Roof Slab to Wall

NS-DS2020

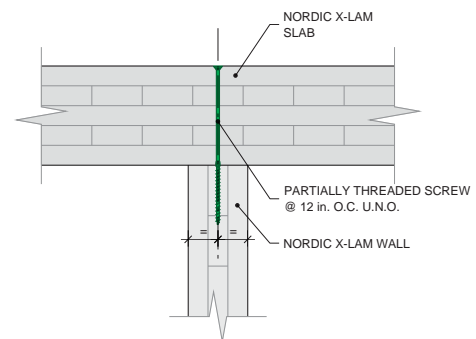
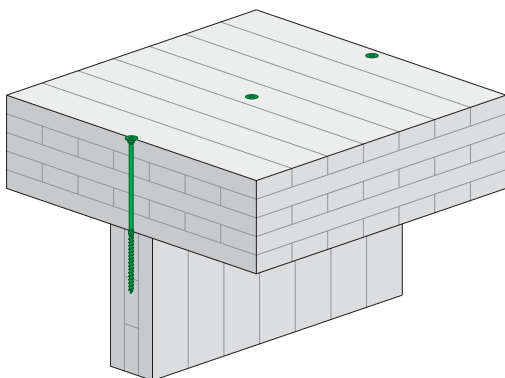

Structure, Floor/Roof-Wall

Screwed Wall to Continuous Floor Slab to Wall

NS-DS2021

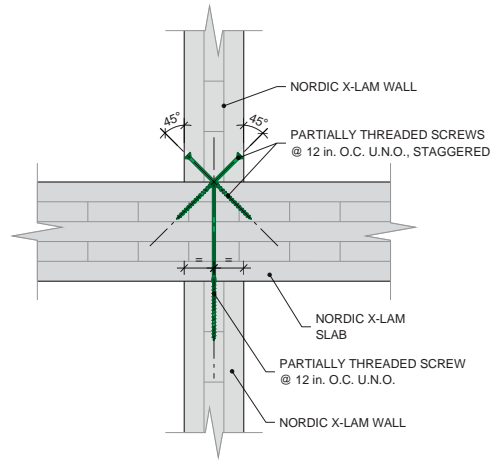
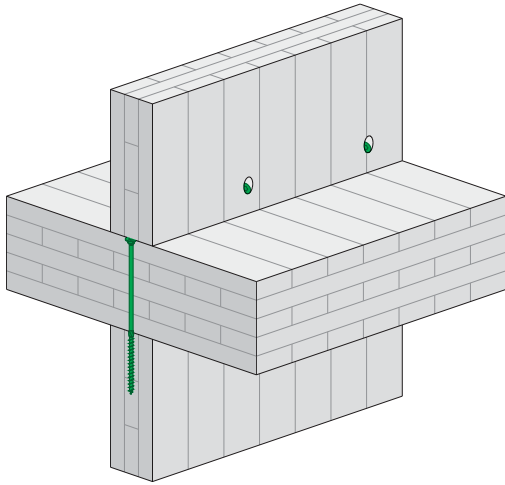

Structure, Floor/Roof-Wall

Screwed Wall to Single Floor Slab to Wall

NS-DS2022

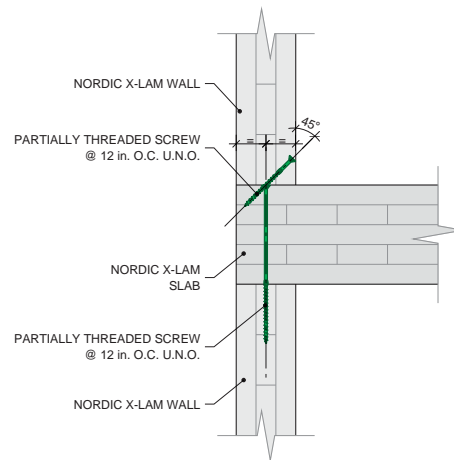
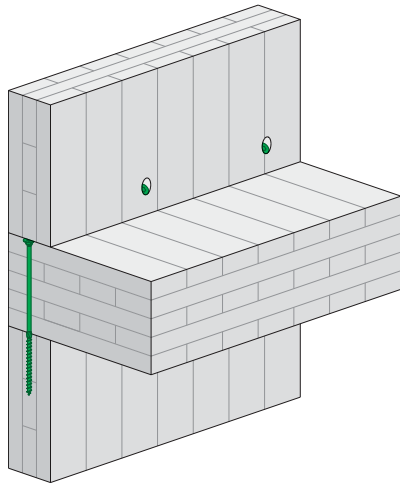

Structure, Floor/Roof-Wall

Wall to Floor Slab with Steel Square to Wall

NS-DS2023

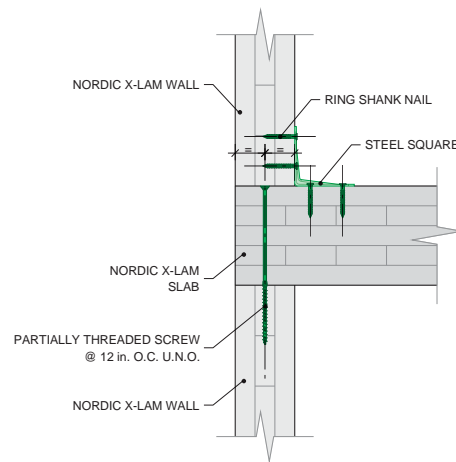
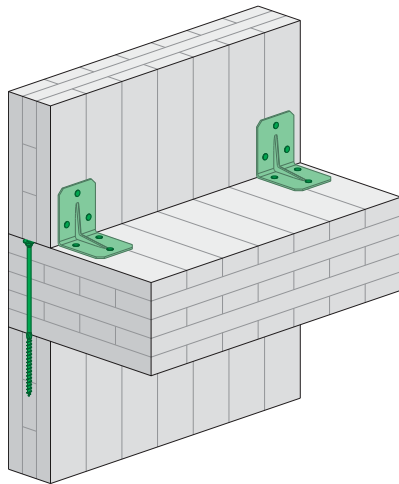

Structure, Floor/Roof-Wall

Wall to Floor Slab with Steel Square to Notched Wall

NS-DS2024

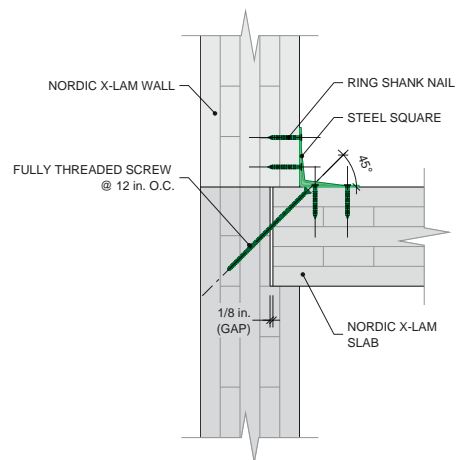
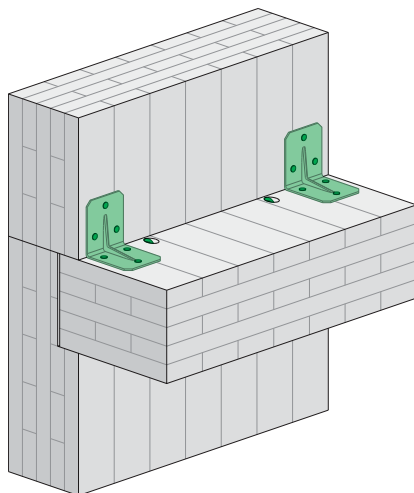

Structure, Floor/Roof-Wall

Sloped Roof Slab to Wall

NS-DS2025

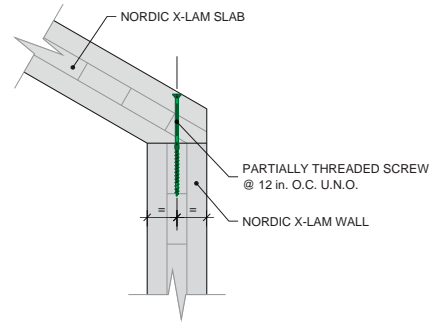
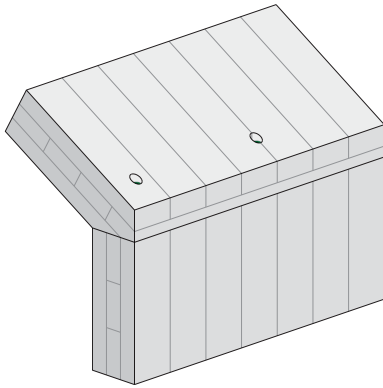

Structure, Lintel

CLT Lintel

NS-DS2026

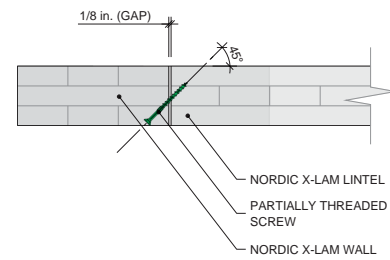
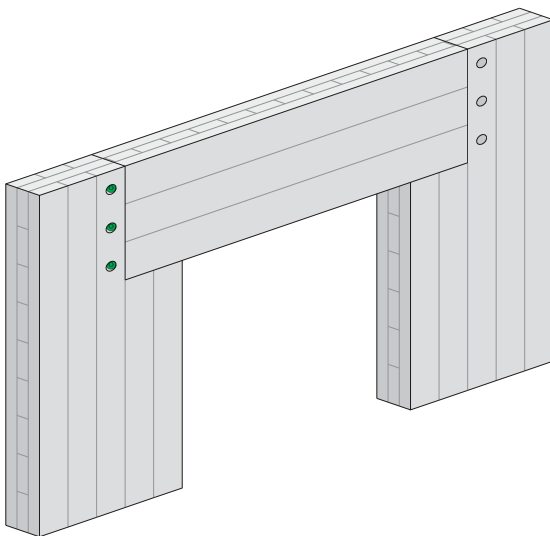

Structure, Lintel

Glulam Lintel

NS-DS2027

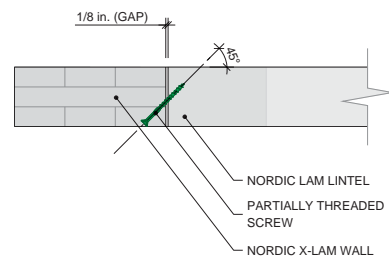
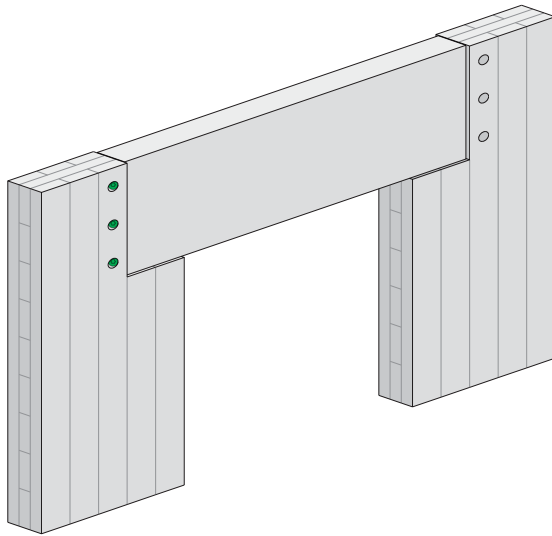

Structure, Panel-Panel

Butt Joint, One Row of Nails

NS-DS2029

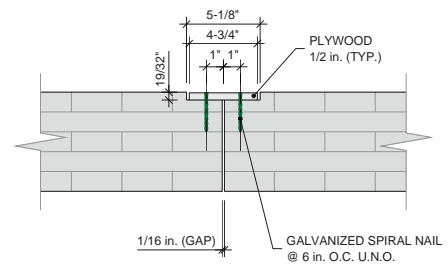
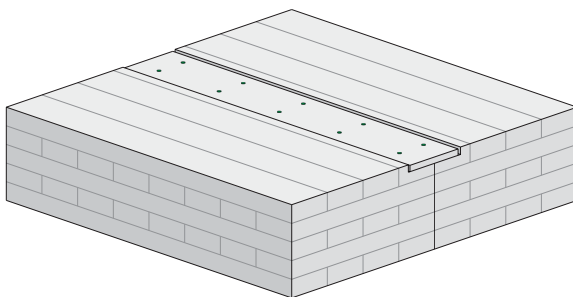

Structure, Panel-Panel

Butt Joint, Two Rows of Nails

NS-DS2030

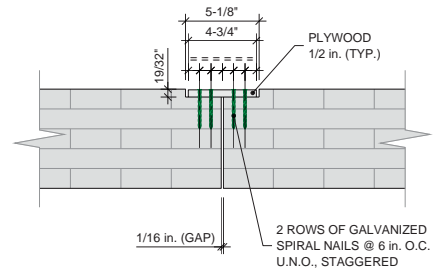
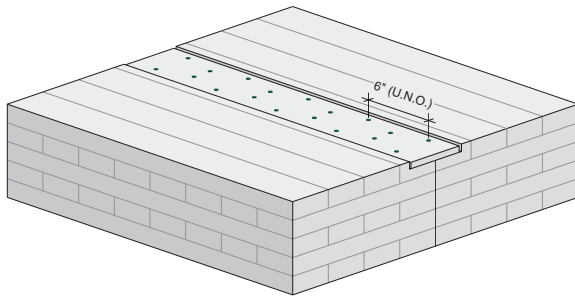

Structure, Panel-Panel

Butt Joint, 45° Screws

NS-DS2069

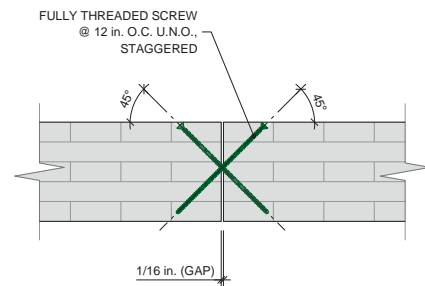
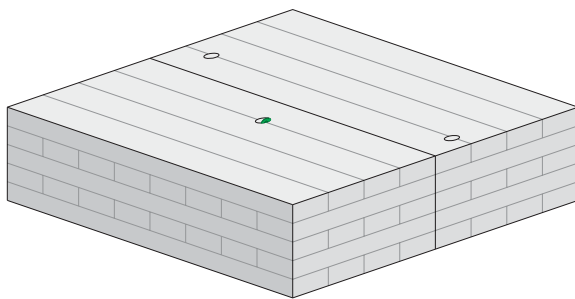

Structure, Panel-Panel

Half-lap Joint

NS-DS2031

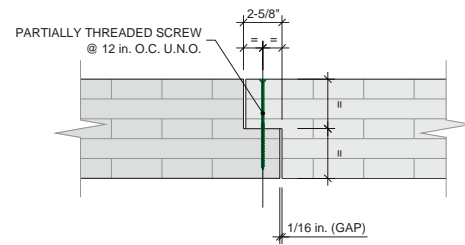
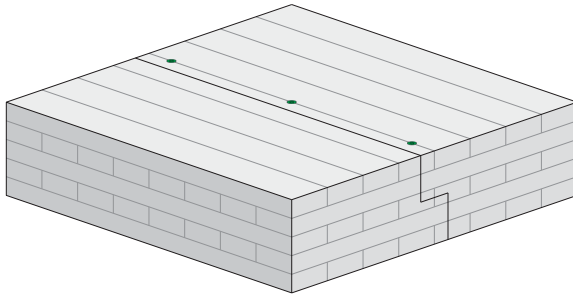

Structure, Wall-Wall

Corner Joint with 90° Screws

NS-DS2032

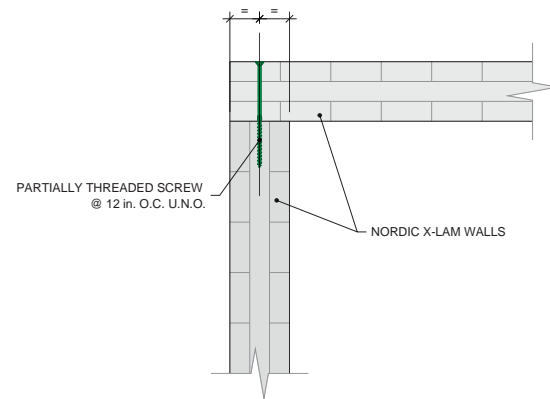
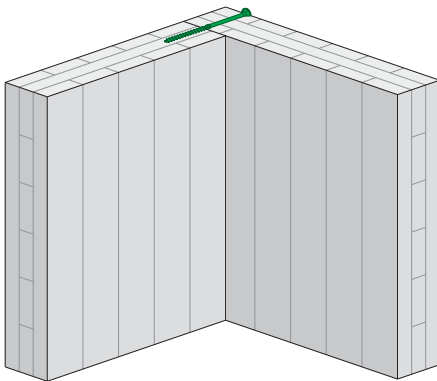

Structure, Wall-Wall

Notched Corner Joint with 90° Screws

NS-DS2033

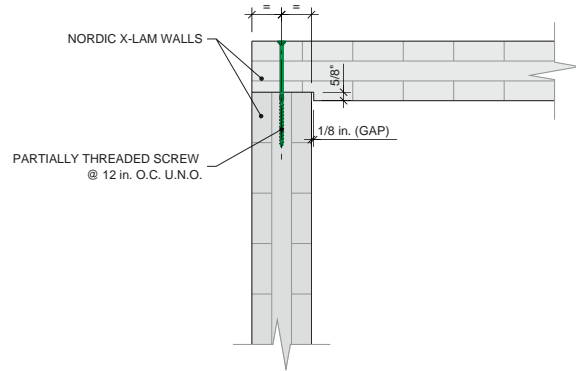
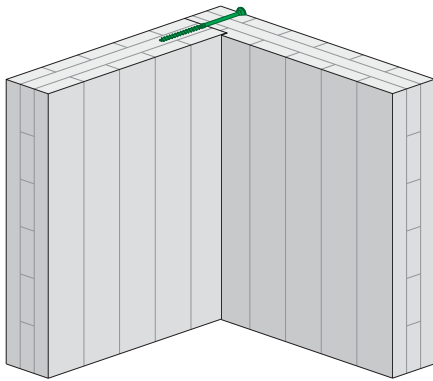

Structure, Wall-Wall

Corner Joint with 45° Screws

NS-DS2034

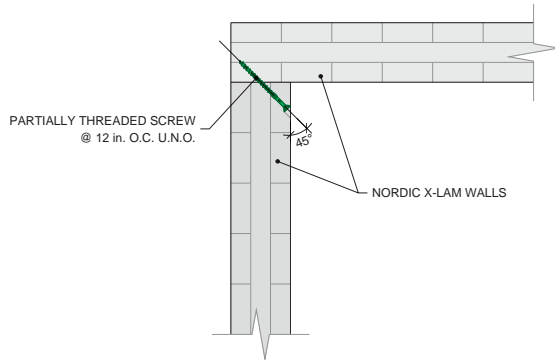
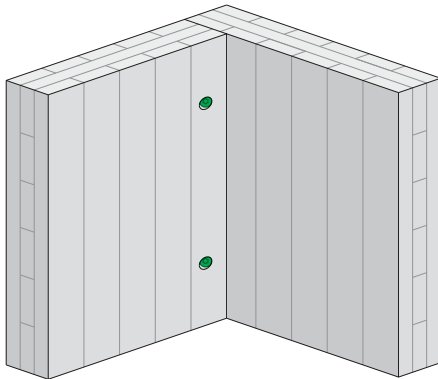

Structure, Wall-Wall

T-joint with 90° Screws

NS-DS2035

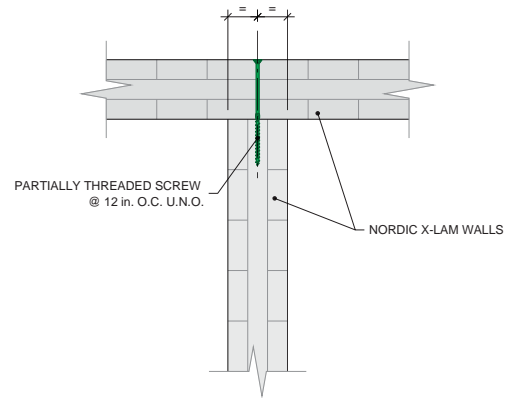
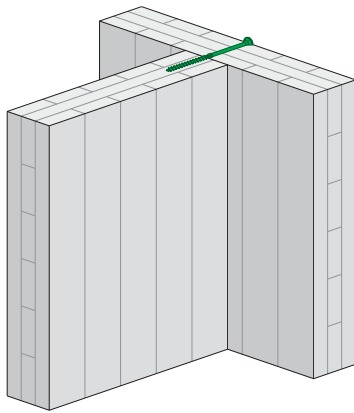

Structure, Wall-Wall

T-joint with 45° Screws

NS-DS2036

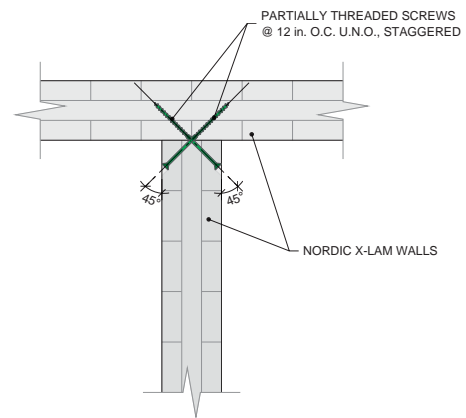
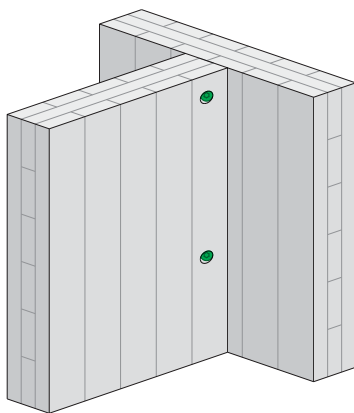

Mechanical, Electrical, and Plumbing

Vertical, Double-member Beam

NS-DS2501

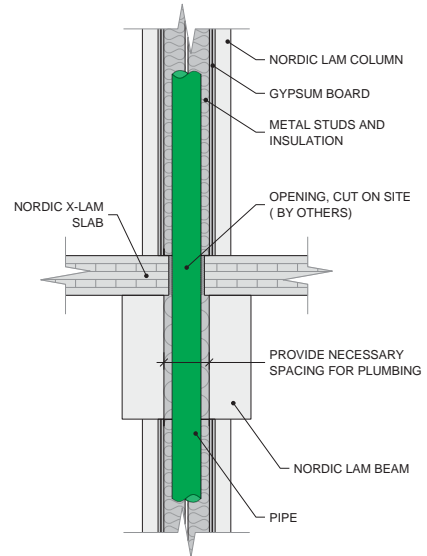
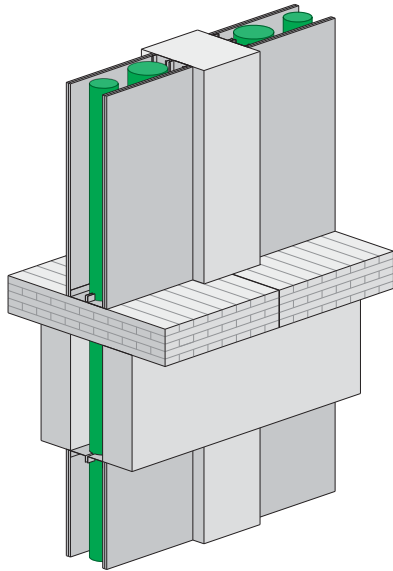

Mechanical, Electrical, and Plumbing

Horizontal, Pre-machined Opening

NS-DS2502

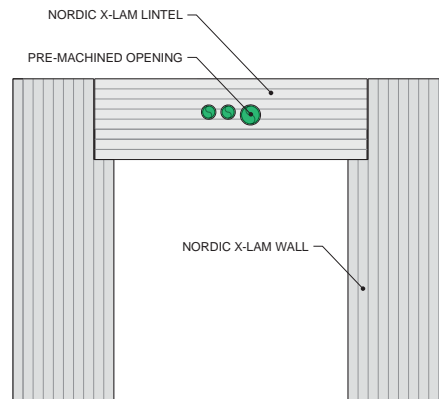
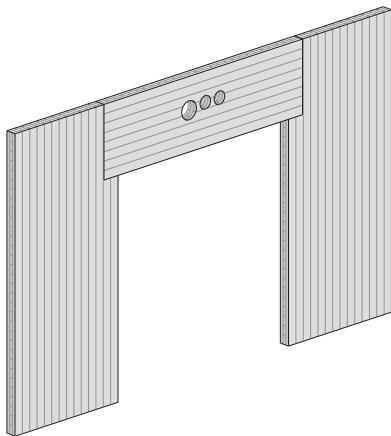

Mechanical, Electrical, and Plumbing

Horizontal, Electrical Box with 38 mm x 64 mm Wood Studs

NS-DS2503

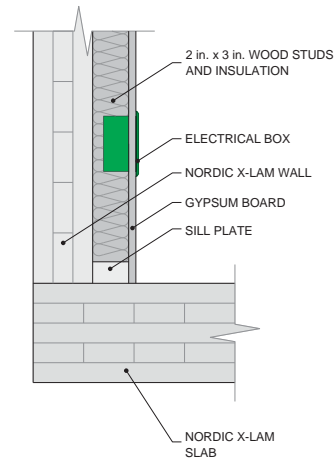
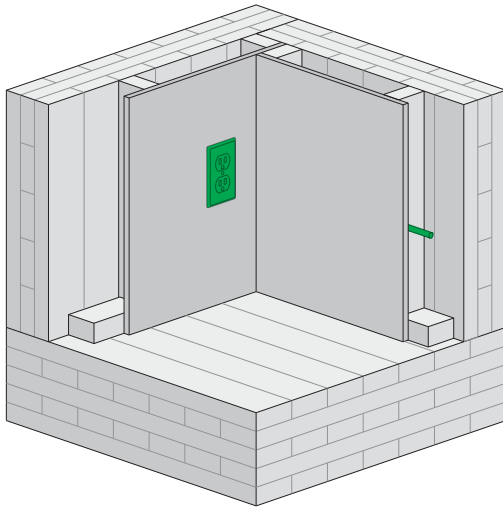

Mechanical, Electrical, and Plumbing

Horizontal, Raised Floor

NS-DS2504

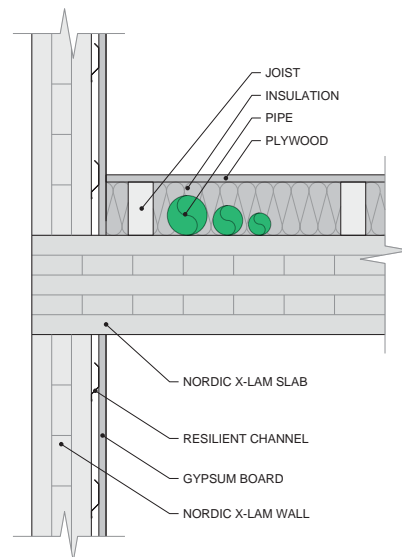
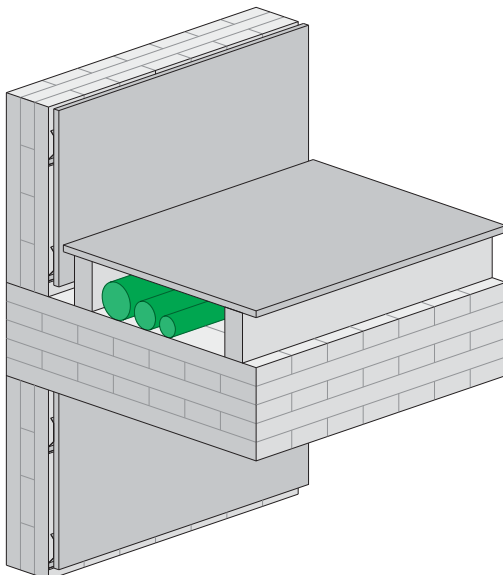

Mechanical, Electrical, and Plumbing

Horizontal, Suspended Ceiling

NS-DS2505

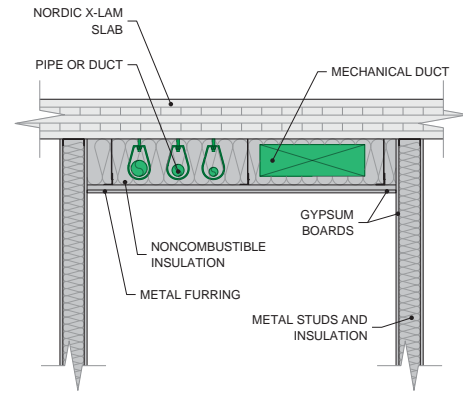
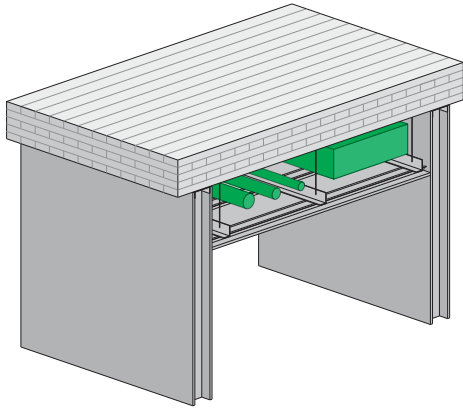

Mechanical, Electrical, and Plumbing

Horizontal, Bevelled Beam

NS-DS2507

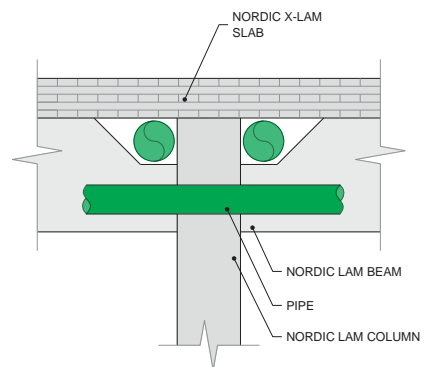
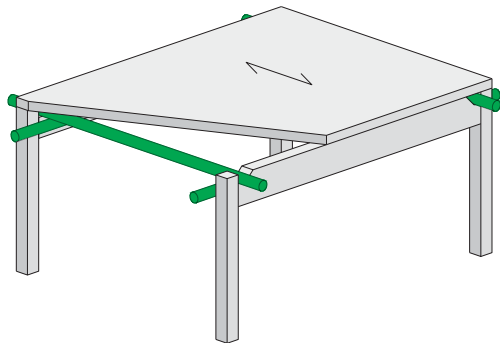

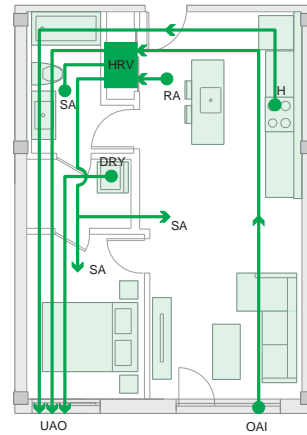
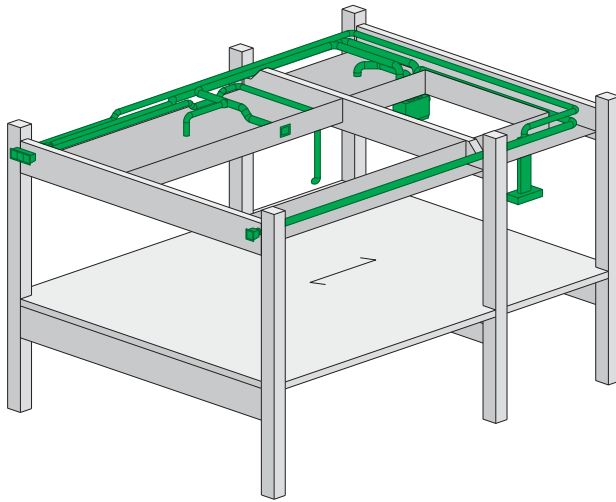

- Legend**
- SA Supply Air
 - H Hood
 - OAI Outdoor Air Intake
 - RA Return Air
 - UAO Used Air Outlet
 - SEC Dryer
 - HRV Heat Recovery Ventilator

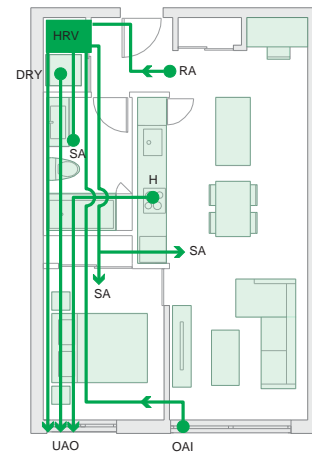
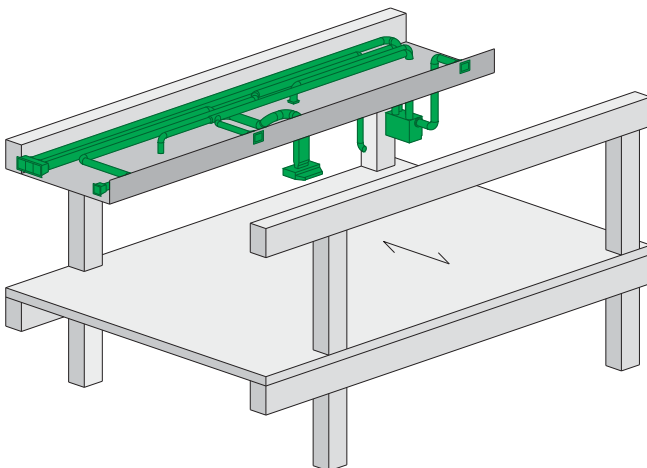

- Legend**
- SA Supply Air
 - H Hood
 - OAI Outdoor Air Intake
 - RA Return Air
 - UAO Used Air Outlet
 - SEC Dryer
 - HRV Heat Recovery Ventilator

NORDIC

TECHNICAL GUIDE
NORDIC X-LAM

NS-GT6 

ASD

VERSION
2026-02-01

ARCHITECTURAL
DETAILS

4

GENERAL NOTES

1.0 General

- 1.1 This document supersedes all previous versions. For the latest version, consult nordic.ca or contact Nordic Structures.
- 1.2 The information contained in this document is provided for information purposes only. This information should not be used for any application without examination and verification of its accuracy, suitability and applicability by a licensed engineer, architect or other professional. Nordic Structures does not guarantee that the information is suitable for any general or particular use, and assumes no responsibility for the use, application of and/or reference to the information.
- 1.3 Certain commercial products are identified in this document in order to properly represent the test procedure. In no case does such identification imply recommendations or endorsement by Nordic Structures, nor does it imply that the product or material identified is the best available for the purpose.
- 1.4 For more information, consult nordic.ca or contact Nordic Structures.

2.0 Fire Safety

- 2.1 The fire resistance rating (FRR) is determined using the design methodology specified in the National Design Specification (NDS) for Wood Construction 2015. The fire resistance rating may also be determined on the basis of the results of tests conducted in conformance with ASTM E119, Standard Test Methods for Fire Tests of Building Construction and Materials.
- 2.2 To determine the fire resistance of an element or assembly according to other assumptions than those specified in this document, consult the Nordic X-Lam technical guide or use Nordic Sizer software.
- 2.3 The fire performance criteria for evaluating the separating function of building elements shall be considered when required by the applicable building code.

- 2.4 For this purpose, among other requirements, many firestop systems suitable for mass timber are available. For more details, consult the product suppliers.
- 2.5 Additional references: Fire-Resistance-Tested Mass Timber Assemblies and Penetrations.

3.0 Envelope

- 3.1 Good thermal insulation is never arbitrary and must always be chosen according to location, area and climate.
- 3.2 The total thermal resistance of an assembly is calculated according to the values of thermal conductivity, λ , and thermal resistance, R, indicated in the following table.
- 3.3 To convert the thermal resistance of the International System (RSI) [$\text{m}^2\text{K}/\text{W}$] to the R-value [$\text{ft}^2\text{Fh}/\text{BTU}$], divide the RSI value by 0.1761.
- 3.4 As stated in technical note NS-NT602-US, Nordic X-Lam cross-laminated timber acts as a vapor barrier.
- 3.5 The use of closed cell spray polyurethane is not recommended for exterior wall assemblies made of cross-laminated timber because of its low permeability.
- 3.6 The study of the building envelope, including the control of condensation, the transfers of heat, air, moisture and sound, as well as the details of joining and fixing of the coverings, shall be carried out in accordance with the applicable building code.

GENERAL NOTES (CONTINUED)

Thermal Resistance of Materials

Product	t (in.)	λ (BTU/ftFh)	R (ft ² Fh/BTU)
Nordic Lam	1	0.0751	1.11
Nordic X-Lam	1	0.0751	1.11
Sawn lumber	1	0.0693	1.20
Spray polyurethane (BASF)	2	0.0116	14.2
Stone wool (Rockwool ComfortBatt R24)	5-1/2	0.0191	24.0
Gypsum board	1/2	0.0919	0.45
Polyisocyanurate (SOPRA-ISO)	-	0.0144	-
Air cavity – Wall	1/2 to 3/4	-	0.91
Air cavity – Ceiling	1/2 to 1-5/8 1-5/8 to 3-1/2	-	0.85 0.91
Interior air film – Wall	-	-	0.68
Interior air film – Ceiling	-	-	0.62
Exterior air film	-	-	0.17

References: Test Report AT-00205 (AIR-INS inc.), Wood Handbook (FPL, 2010), Evaluation Listing CCMC 13588-L (2011), Technical Data Sheet (Rockwool, 2017), Technical Data Sheet 190304SCANE (Soprema, 2019) and Table A-9.36.2.4.1.1)-D of NBC 2015.

4.0 Acoustics

- 4.1 The Sound Transmission Class (STC) rating describes the performance of the separating wall or floor/ceiling assembly, whereas the Field Sound Transmission Class (FSTC) takes into consideration the performance of the separating element as well as the flanking transmission paths. Also, building professionals should ensure that floors are designed to minimize impact transmission. For more details, see the IBC 2018, Section 1206.
- 4.2 The following pages present separating assemblies that may comply with the applicable building code. However, selecting an appropriate separating assembly is only one part of the solution for reducing airborne sound transmission between adjoining spaces: to fully address the sound performance of the whole system, flanking assemblies must be connected to the separating assembly. For more details, see the Nordic X-Lam Technical Guide.
- 4.3 Unless otherwise noted, concrete topping and prefabricated concrete topping used in assemblies have a density of 2,710 kg/m³.
- 4.4 The use of prefabricated concrete topping in floor assemblies is only required by the acoustical testing procedure.
- 4.5 The use of an acoustic membrane under a floor covering is recommended, especially when it is a hard surface coating (e.g. ceramic).
- 4.6 Unless otherwise noted, the acoustic performance values are derived from test results from a certified laboratory. Test reports are available upon request.
- 4.7 Additional references:
 - [WoodWorks – Acoustics and Mass Timber: Room-to-Room Noise Control](#)
 - [WoodWorks – Acoustically-Tested Mass Timber Assemblies](#)
 - [University of Oregon – Acoustic Lab Testing of Typical Multi-Family Residential Wall and Floor Assemblies](#)

Architecture, Assembly

Exterior Wall

NS-DA2000

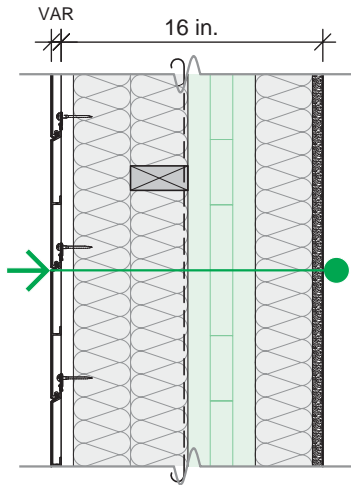

E1

Fire-resistance rating	FRR ^(a)	1 h
Thermal resistance	RSI / R	6.7 / 38
Acoustic ratings	STC / FSTC	n.a. / n.a.
	IIC / FIIC	n.a. / n.a.

a) The fire-resistance rating is based on an effective length of 10 feet and on a concentric uniform load of 12,450 plf.

- CLADDING (UP TO THE DESIGNER)
- AIR GAP 3/4 in.
- WOOD STUDS 2 in. X 4 in. @ 24 in. O.C.
- WOOD FURRING 2 in. X 4 in. @ 24 in. O.C.
- 2 ROWS OF STONE WOOL INSULATION 3-1/2 in. EA.
- AIR BARRIER MEMBRANE
- NORDIC X-LAM 4-1/8 in.
- WOOD STUDS 2 in. X 4 in. @ 24 in. O.C.
- 1 ROW OF STONE WOOL INSULATION 3-1/2 in.
- 1 TYPE X GYPSUM BOARD 5/8 in.

Architecture, Assembly

Exterior Wall

NS-DA2001

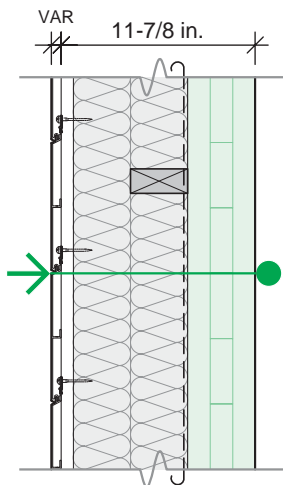

E2

Fire-resistance rating	FRR ^(a)	30 min
Thermal resistance	RSI / R	4.8 / 27
Acoustic ratings	STC / FSTC	n.a. / n.a.
	IIC / FIIC	n.a. / n.a.

a) The fire-resistance rating is based on an effective length of 10 feet and on a concentric uniform load of 12,450 plf.

- CLADDING (UP TO THE DESIGNER)
- AIR GAP 3/4 in.
- WOOD STUDS 2 in. X 4 in. @ 24 in. O.C.
- WOOD FURRING 2 in. X 4 in. @ 24 in. O.C.
- 2 ROWS OF STONE WOOL INSULATION 3-1/2 in. EA.
- AIR BARRIER MEMBRANE
- NORDIC X-LAM 4-1/8 in.

Architecture, Assembly

Exterior Wall

NS-DA2002

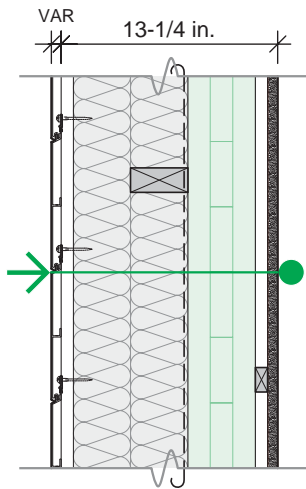

E3

Fire-resistance rating	FRR ^(a)	1 h
Thermal resistance	RSI / R	5.0 / 28
Acoustic ratings	STC / FSTC	n.a. / n.a.
	IIC / FIIC	n.a. / n.a.

a) The fire-resistance rating is based on an effective length of 10 feet and on a concentric uniform load of 12,450 plf.

- CLADDING (UP TO THE DESIGNER)
- AIR GAP 3/4 in.
- WOOD STUDS 2 in. X 4 in. @ 24 in. O.C.
- WOOD FURRING 2 in. X 4 in. @ 24 in. O.C.
- 2 ROWS OF STONE WOOL INSULATION 3-1/2 in. EA.
- AIR BARRIER MEMBRANE
- NORDIC X-LAM 4-1/8 in.
- WOOD FURRING 3/4 in. @ 24 in. O.C.
- 1 TYPE X GYPSUM BOARD 5/8 in.

Architecture, Assembly

Exterior Wall

NS-DA2003

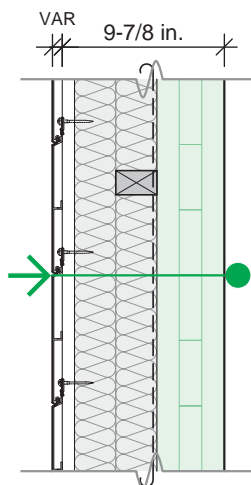

E4

Fire-resistance rating	FRR ^(a)	30 min
Thermal resistance	RSI / R	3.7 / 21
Acoustic ratings	STC / FSTC	n.a. / n.a.
	IIC / FIIC	n.a. / n.a.

a) The fire-resistance rating is based on an effective length of 10 feet and on a concentric uniform load of 12,450 plf.

- CLADDING (UP TO THE DESIGNER)
- AIR GAP 3/4 in.
- WOOD STUDS 2 in. X 3 in. @ 24 in. O.C.
- WOOD FURRING 2 in. X 3 in. @ 24 in. O.C.
- 2 ROWS OF STONE WOOL INSULATION 2-1/2 in. EA.
- AIR BARRIER MEMBRANE
- NORDIC X-LAM 4-1/8 in.

Architecture, Assembly

Exterior Wall

NS-DA2004

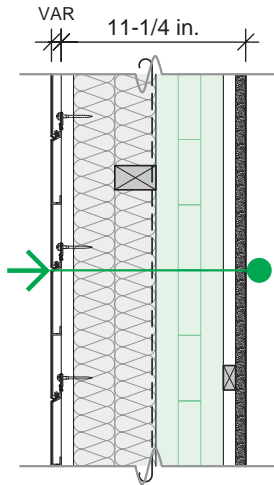

E5

Fire-resistance rating	FRR ^(a)	1 h
Thermal resistance	RSI / R	4.0 / 22
Acoustic ratings	STC / FSTC	n.a. / n.a.
	IIC / FIIC	n.a. / n.a.

a) The fire-resistance rating is based on an effective length of 10 feet and on a concentric uniform load of 12,450 plf.

- CLADDING (UP TO THE DESIGNER)
- AIR GAP 3/4 in.
- WOOD STUDS 2 in. X 3 in. @ 24 in. O.C.
- WOOD FURRING 2 in. X 3 in. @ 24 in. O.C.
- 2 ROWS OF STONE WOOL INSULATION 2-1/2 in. EA.
- AIR BARRIER MEMBRANE
- NORDIC X-LAM 4-1/8 in.
- WOOD FURRING 3/4 in. @ 24 in. O.C.
- 1 TYPE X GYPSUM BOARD 5/8 in.

Architecture, Assembly

Exterior Wall

NS-DA2005

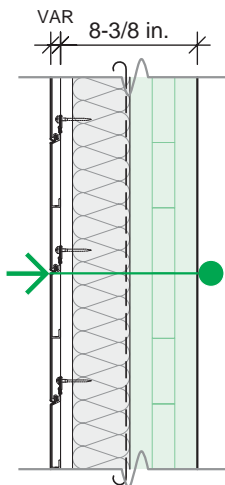

E6

Fire-resistance rating	FRR ^(a)	30 min
Thermal resistance	RSI / R	2.9 / 16
Acoustic ratings	STC / FSTC	n.a. / n.a.
	IIC / FIIC	n.a. / n.a.

a) The fire-resistance rating is based on an effective length of 10 feet and on a concentric uniform load of 12,450 plf.

- CLADDING (UP TO THE DESIGNER)
- AIR GAP 3/4 in.
- WOOD STUDS 2 in. X 4 in. @ 24 in. O.C.
- 1 ROW OF STONE WOOL INSULATION 3-1/2 in.
- AIR BARRIER MEMBRANE
- NORDIC X-LAM 4-1/8 in.

Architecture, Assembly

Exterior Wall

NS-DA2006

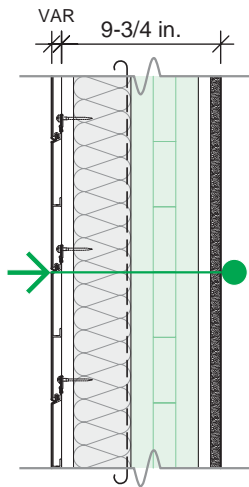

E7

Fire-resistance rating	FRR ^(a)	1 h
Thermal resistance	RSI / R	3.1 / 18
Acoustic ratings	STC / FSTC	n.a. / n.a.
	IIC / FIIC	n.a. / n.a.

a) The fire-resistance rating is based on an effective length of 10 feet and on a concentric uniform load of 12,450 plf.

- CLADDING (UP TO THE DESIGNER)
- AIR GAP 3/4 in.
- WOOD STUDS 2 in. X 4 in. @ 24 in. O.C.
- 1 ROW OF STONE WOOL INSULATION 3-1/2 in.
- AIR BARRIER MEMBRANE
- NORDIC X-LAM 4-1/8 in.
- WOOD FURRING 3/4 in. @ 24 in. O.C.
- 1 TYPE X GYPSUM BOARD 5/8 in.

Architecture, Assembly

Exterior Wall

NS-DA2007

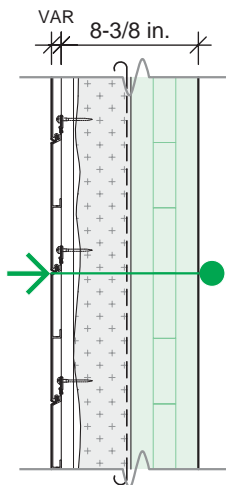

E8

Fire-resistance rating	FRR ^(a)	30 min
Thermal resistance	RSI / R	3.4 / 20
Acoustic ratings	STC / FSTC	n.a. / n.a.
	IIC / FIIC	n.a. / n.a.

a) The fire-resistance rating is based on an effective length of 10 feet and on a concentric uniform load of 12,450 plf.

- CLADDING (UP TO THE DESIGNER)
- AIR GAP 3/4 in.
- WOOD STUDS 2 in. X 4 in. @ 24 in. O.C.
- SPRAYED POLYURETHANE FOAM 3-1/2 in.
- AIR BARRIER MEMBRANE
- NORDIC X-LAM 4-1/8 in.

Architecture, Assembly

Exterior Wall

NS-DA2008

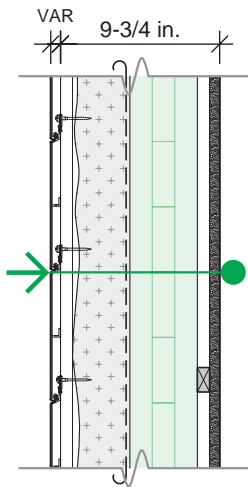

E9

Fire-resistance rating	FRR ^(a)	1 h
Thermal resistance	RSI / R	3.7 / 21
Acoustic ratings	STC / FSTC	n.a. / n.a.
	IIC / FIIC	n.a. / n.a.

a) The fire-resistance rating is based on an effective length of 10 feet and on a concentric uniform load of 12,450 plf.

- CLADDING (UP TO THE DESIGNER)
- AIR GAP 3/4 in.
- WOOD STUDS 2 in. X 4 in. @ 24 in. O.C.
- SPRAYED POLYURETHANE FOAM 3-1/2 in.
- AIR BARRIER MEMBRANE
- NORDIC X-LAM 4-1/8 in.
- WOOD FURRING 3/4 in. @ 24 in. O.C.
- 1 TYPE X GYPSUM BOARD 5/8 in.

Architecture, Assembly

Exterior Wall

NS-DA2009

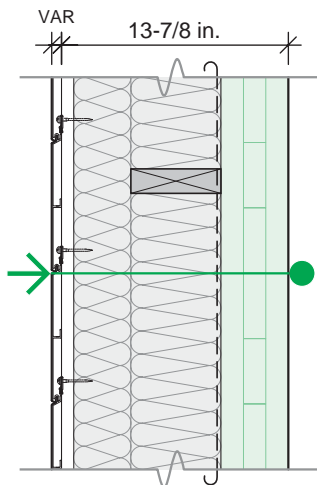

E10

Fire-resistance rating	FRR ^(a)	30 min
Thermal resistance	RSI / R	5.8 / 33
Acoustic ratings	STC / FSTC	n.a. / n.a.
	IIC / FIIC	n.a. / n.a.

a) The fire-resistance rating is based on an effective length of 10 feet and on a concentric uniform load of 12,450 plf.

- CLADDING (UP TO THE DESIGNER)
- AIR GAP 3/4 in.
- WOOD STUDS 2 in. X 4 in. @ 24 in. O.C.
- WOOD FURRING 2 in. X 6 in. @ 24 in. O.C.
- 1 ROW OF STONE WOOL INSULATION 3-1/2 in.
- 1 ROW OF STONE WOOL INSULATION 5-1/2 in.
- AIR BARRIER MEMBRANE
- NORDIC X-LAM 4-1/8 in.

Architecture, Assembly

Exterior Wall

NS-DA2010

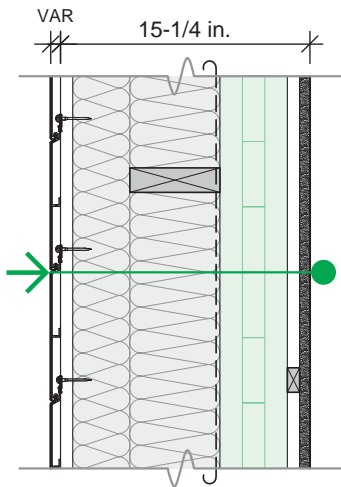

E11

Fire-resistance rating	FRR ^(a)	1 h
Thermal resistance	RSI / R	6.1 / 35
Acoustic ratings	STC / FSTC	n.a. / n.a.
	IIC / FIIC	n.a. / n.a.

a) The fire-resistance rating is based on an effective length of 10 feet and on a concentric uniform load of 12,450 plf.

- CLADDING (UP TO THE DESIGNER)
- AIR GAP 3/4 in.
- WOOD STUDS 2 in. X 4 in. @ 24 in. O.C.
- WOOD FURRING 2 in. X 6 in. @ 24 in. O.C.
- 1 ROW OF STONE WOOL INSULATION 3-1/2 in.
- 1 ROW OF STONE WOOL INSULATION 5-1/2 in.
- AIR BARRIER MEMBRANE
- NORDIC X-LAM 4-1/8 in.
- WOOD FURRING 3/4 in. @ 24 in. O.C.
- 1 TYPE X GYPSUM BOARD 5/8 in.

Architecture, Assembly

Partition

NS-DA2100

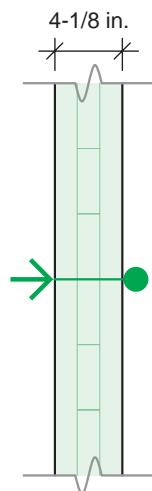

P1

Fire-resistance rating	FRR ^(a)	30 min / 30 min
Thermal resistance	RSI / R	n.a. / n.a.
Acoustic ratings	STC ^(b) / FSTC	33 / n.a.
	IIC / FIIC	n.a. / n.a.

a) The fire-resistance ratings on each side of the partition are based on an effective length of 10 feet and on a concentric uniform load of 12,450 plf.

b) Composition and acoustic performance taken from the CLT Handbook – Canadian Edition (FPInnovations, 2011). Acoustic performance based on a CLT thickness of 95-115 mm (3-3/4 in. to 4-1/2 in.).

- NORDIC X-LAM 4-1/8 in.

Architecture, Assembly

Partition

NS-DA2101

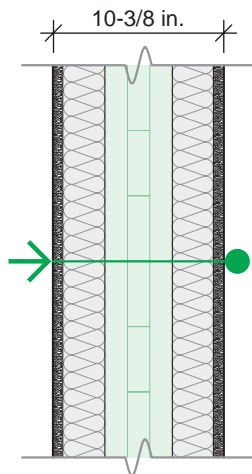

P2

Fire-resistance rating	FRR ^(a)	1 h / 1 h
------------------------	--------------------	-----------

Thermal resistance	RSI / R	n.a. / n.a.
--------------------	---------	-------------

	STC ^(b) / FSTC	58 / n.a.
--	---------------------------	-----------

Acoustic ratings	IIC / FIIC	n.a. / n.a.
------------------	------------	-------------

- a) The fire-resistance ratings on each side of the partition are based on an effective length of 10 feet and on a concentric uniform load of 12,450 plf.
 b) Composition and acoustic performance taken from the CLT Handbook – Canadian Edition (FPIInnovations, 2011). Acoustic performance based on a CLT thickness of 95-115 mm (3-3/4 in. to 4-1/2 in.).

- 1 TYPE X GYPSUM BOARD 5/8 in.
- 1 ROW OF MINERAL WOOL INSULATION 2-1/2 in.
- WOOD STUDS 2 in. X 3 in. @ 24 in. O.C.
- NORDIC X-LAM 4-1/8 in.
- WOOD STUDS 2 in. X 3 in. @ 24 in. O.C. OFF-CENTERED FROM THE OTHER ROW OF WOOD STUDS
- 1 ROW OF MINERAL WOOL INSULATION 2-1/2 in.
- 1 TYPE X GYPSUM BOARD 5/8 in.

Architecture, Assembly

Partition

NS-DA2102

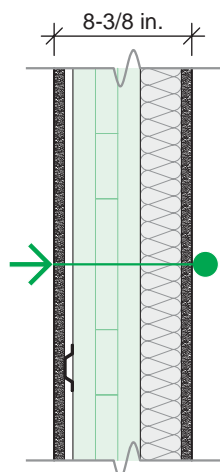

P3

Fire-resistance rating	FRR ^(a)	1 h / 1 h
------------------------	--------------------	-----------

Thermal resistance	RSI / R	n.a. / n.a.
--------------------	---------	-------------

	STC / FSTC	53 / n.a.
--	------------	-----------

Acoustic ratings	IIC / FIIC	n.a. / n.a.
------------------	------------	-------------

- a) The fire-resistance ratings on each side of the partition are based on an effective length of 10 feet and on a concentric uniform load of 12,450 plf.

- 1 TYPE X GYPSUM BOARD 5/8 in.
- RESILIENT CHANNELS 1/2 in. @ 16 in. O.C. INSTALLED HORIZONTALLY
- NORDIC X-LAM 4-1/8 in.
- WOOD STUDS 2 in. X 3 in. @ 24 in. O.C.
- 1 ROW OF MINERAL WOOL INSULATION 2-1/2 in.
- 1 TYPE X GYPSUM BOARD 5/8 in.

Architecture, Assembly

Partition

NS-DA2103

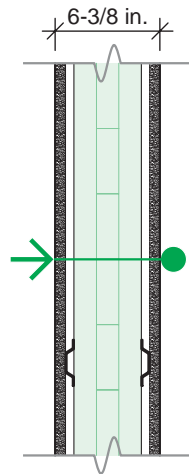

P4

Fire-resistance rating	FRR ^(a)	1 h / 1 h
Thermal resistance	RSI / R	n.a. / n.a.
Acoustic ratings	STC ^(b) / FSTC	37 / n.a.
	IIC / FIIC	n.a. / n.a.

- a) The fire-resistance ratings on each side of the partition are based on an effective length of 10 feet and on a concentric uniform load of 12,450 plf.
- b) Composition and acoustic performance taken from the CLT Handbook – Canadian Edition (FPInnovations, 2011). Acoustic performance based on a CLT thickness of 95-115 mm (3-3/4 in. to 4-1/2 in.).
- 1 TYPE X GYPSUM BOARD 5/8 in.
 - RESILIENT CHANNELS 1/2 in. @ 16 in. O.C. INSTALLED HORIZONTALLY
 - NORDIC X-LAM 4-1/8 in.
 - RESILIENT CHANNELS 1/2 in. @ 16 in. O.C. INSTALLED HORIZONTALLY
 - 1 TYPE X GYPSUM BOARD 5/8 in.

Architecture, Assembly

Partition

NS-DA2104

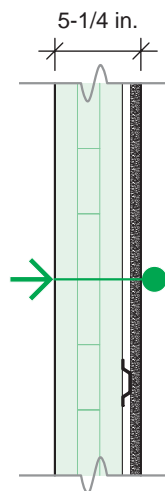

P5

Fire-resistance rating	FRR ^(a)	30 min / 1 h
Thermal resistance	RSI / R	n.a. / n.a.
Acoustic ratings	STC ^(b) / FSTC	37 / n.a.
	IIC / FIIC	n.a. / n.a.

- a) The fire-resistance ratings on each side of the partition are based on an effective length of 10 feet and on a concentric uniform load of 12,450 plf.
- b) Composition and acoustic performance taken from the CLT Handbook – Canadian Edition (FPInnovations, 2011). Acoustic performance based on a CLT thickness of 95-115 mm (3-3/4 in. to 4-1/2 in.).
- NORDIC X-LAM 4-1/8 in.
 - RESILIENT CHANNELS 1/2 in. @ 16 in. O.C. INSTALLED HORIZONTALLY
 - 1 TYPE X GYPSUM BOARD 5/8 in.

Architecture, Assembly

Partition

NS-DA2105

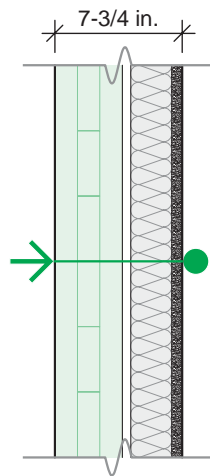

P6

Fire-resistance rating	FRR ^(a)	30 min / 1 h
Thermal resistance	RSI / R	n.a. / n.a.
Acoustic ratings	STC / FSTC	n.a. / 47
	IIC / FIIC	n.a. / n.a.

a) The fire-resistance ratings on each side of the partition are based on an effective length of 10 feet and on a concentric uniform load of 12,450 plf.

- NORDIC X-LAM 4-1/8 in.
- AIR GAP 1/2 in.
- WOOD STUDS 2 in. X 3 in. @ 16 in. O.C.
- 1 ROW OF MINERAL WOOL INSULATION 2-1/2 in.
- 1 TYPE X GYPSUM BOARD 5/8 in.

Architecture, Assembly

Partition

NS-DA2106

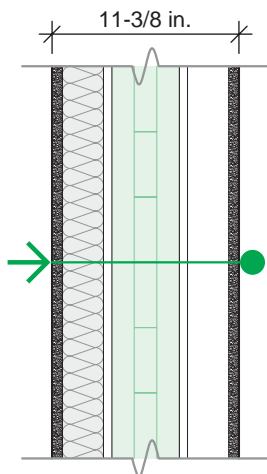

P7

Fire-resistance rating	FRR ^(a)	1 h / 1 h
Thermal resistance	RSI / R	n.a. / n.a.
Acoustic ratings	STC / FSTC	n.a. / 50
	IIC / FIIC	n.a. / n.a.

a) The fire-resistance ratings on each side of the partition are based on an effective length of 10 feet and on a concentric uniform load of 12,450 plf.

- 1 TYPE X GYPSUM BOARD 5/8 in.
- 1 ROW OF MINERAL WOOL INSULATION 2-1/2 in.
- WOOD STUDS 2 in. X 3 in. @ 16 in. O.C.
- AIR GAP 1/2 in.
- NORDIC X-LAM 4-1/8 in.
- AIR GAP 1/2 in.
- WOOD STUDS 2 in. X 3 in. @ 16 in. O.C.
- 1 TYPE X GYPSUM BOARD 5/8 in.

Architecture, Assembly

Partition

NS-DA2107

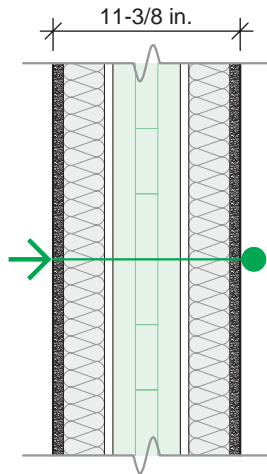

P8

Fire-resistance rating	FRR ^(a)	1 h / 1 h
Thermal resistance	RSI / R	n.a. / n.a.
Acoustic ratings	STC / FSTC	n.a. / 54
	IIC / FIIC	n.a. / n.a.

a) The fire-resistance ratings on each side of the partition are based on an effective length of 10 feet and on a concentric uniform load of 12,450 plf.

- 1 TYPE X GYPSUM BOARD 5/8 in.
- 1 ROW OF MINERAL WOOL INSULATION 2-1/2 in.
- WOOD STUDS 2 in. X 3 in. @ 16 in. O.C.
- AIR GAP 1/2 in.
- NORDIC X-LAM 4-1/8 in.
- AIR GAP 1/2 in.
- WOOD STUDS 2 in. X 3 in. @ 16 in. O.C.
- 1 ROW OF MINERAL WOOL INSULATION 2-1/2 in.
- 1 TYPE X GYPSUM BOARD 5/8 in.

Architecture, Assembly

Partition

NS-DA2108

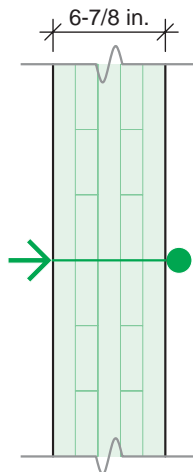

P9

Fire-resistance rating	FRR ^(a)	1.5 h / 1.5 h
Thermal resistance	RSI / R	n.a. / n.a.
Acoustic ratings	STC / FSTC	37 / n.a.
	IIC / FIIC	n.a. / n.a.

a) The fire-resistance ratings on each side of the partition are based on an effective length of 10 feet and on a concentric uniform load of 32,150 plf.

- NORDIC X-LAM 6-7/8 in.

Architecture, Assembly

Partition

NS-DA2109

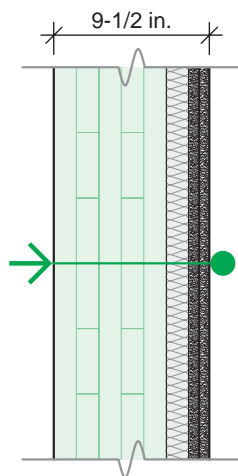

P10

Fire-resistance rating	FRR ^(a)	1.5 h / 2.5 h
Thermal resistance	RSI / R	n.a. / n.a.
Acoustic ratings	STC / FSTC	53 / n.a.
	IIC / FIIC	n.a. / n.a.

a) The fire-resistance ratings on each side of the partition are based on an effective length of 10 feet and on a concentric uniform load of 32,150 plf.

- NORDIC X-LAM 6-7/8 in.
- Z-CHANNELS (26 GAUGE) 1-3/8 in. @ 16 in. O.C.
INSTALLED VERTICALLY
- 1 ROW OF FIBERGLASS INSULATION OF TYPE "ROSE FIBERGLAS ECOTOUCH" 1-1/2 in.
- 2 TYPE X GYPSUM BOARDS 5/8 in. EA.

Architecture, Assembly

Partition

NS-DA2110

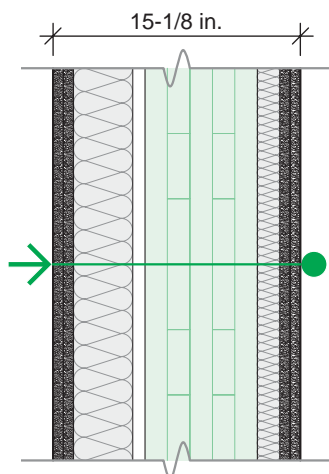

P11

Fire-resistance rating	FRR ^(a)	2.5 h / 2.5 h
Thermal resistance	RSI / R	n.a. / n.a.
Acoustic ratings	STC / FSTC	71 / n.a.
	IIC / FIIC	n.a. / n.a.

a) The fire-resistance ratings on each side of the partition are based on an effective length of 10 feet and on a concentric uniform load of 32,150 plf.

- 2 TYPE X GYPSUM BOARDS 5/8 in. EA.
- METAL STUDS (26 GAUGE) 1-1/4 in. X 3-5/8 in. @ 16 in. O.C.
- 1 ROW OF FIBERGLASS INSULATION OF TYPE "ROSE FIBERGLAS ECOTOUCH" 3-5/8 in.
- AIR GAP 3/4 in.
- NORDIC X-LAM 6-7/8 in.
- Z-CHANNELS (26 GAUGE) 1-3/8 in. @ 16 in. O.C.
INSTALLED VERTICALLY
- 1 ROW OF FIBERGLASS INSULATION OF TYPE "ROSE FIBERGLAS ECOTOUCH" 1-1/2 in.
- 2 TYPE X GYPSUM BOARDS 5/8 in. EA.

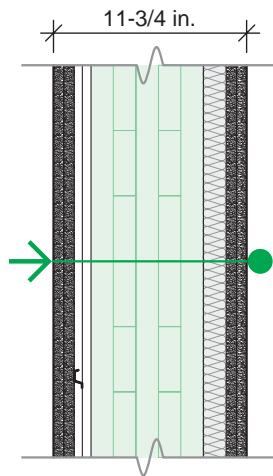

P12

Fire-resistance rating	FRR ^(a)	2.5 h / 2.5 h
Thermal resistance	RSI / R	n.a. / n.a.
Acoustic ratings	STC / FSTC	53 / n.a.
	IIC / FIIC	n.a. / n.a.

a) The fire-resistance ratings on each side of the partition are based on an effective length of 10 feet and on a concentric uniform load of 32,150 plf.

- 2 TYPE X GYPSUM BOARDS 5/8 in. EA.
- RESILIENT CHANNELS 1/2 in. @ 16 in. O.C.
INSTALLED HORIZONTALLY
- PLYWOOD STRIPS 1/2 in. @ 16 in. O.C.
- NORDIC X-LAM 6-7/8 in.
- Z-CHANNELS (26 GAUGE) 1-3/8 in. @ 16 in. O.C.
INSTALLED VERTICALLY
- 1 ROW OF FIBERGLASS INSULATION OF TYPE
"ROSE FIBERGLAS ECOTOUCH" 1-1/2 in.
- 2 TYPE X GYPSUM BOARDS 5/8 in. EA.

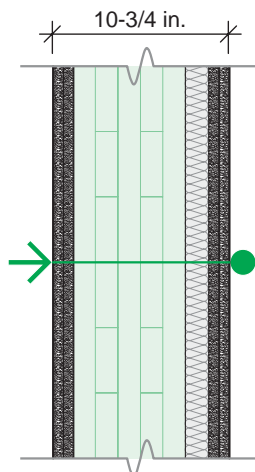

P13

Fire-resistance rating	FRR ^(a)	2.5 h / 2.5 h
Thermal resistance	RSI / R	n.a. / n.a.
Acoustic ratings	STC / FSTC	53 / n.a.
	IIC / FIIC	n.a. / n.a.

a) The fire-resistance ratings on each side of the partition are based on an effective length of 10 feet and on a concentric uniform load of 32,150 plf.

- 2 TYPE X GYPSUM BOARDS 5/8 in. EA.
- NORDIC X-LAM 6-7/8 in.
- Z-CHANNELS (26 GAUGE) 1-3/8 in. @ 16 in. O.C.
INSTALLED VERTICALLY
- 1 ROW OF FIBERGLASS INSULATION OF TYPE
"ROSE FIBERGLAS ECOTOUCH" 1-1/2 in.
- 2 TYPE X GYPSUM BOARDS 5/8 in. EA.

Architecture, Assembly

Partition

NS-DA2113

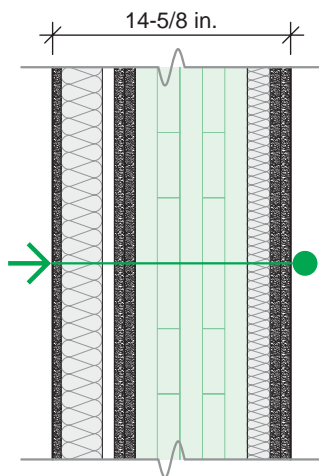

P14

Fire-resistance rating	FRR ^(a)	2.5 h / 2.5 h
------------------------	--------------------	---------------

Thermal resistance	RSI / R	n.a. / n.a.
--------------------	---------	-------------

Acoustic ratings	STC / FSTC	65 / n.a.
	IIC / FIIC	n.a. / n.a.

a) The fire-resistance ratings on each side of the partition are based on an effective length of 10 feet and on a concentric uniform load of 32,150 plf.

- 1 TYPE C GYPSUM BOARD 1/2 in.
- METAL STUDS (26 GAUGE) 1-1/4 in. X 2-1/2 in. @ 16 in. O.C.
- 1 ROW OF STONE WOOL INSULATION OF TYPE "ROXUL AFB" 2-1/2 in.
- AIR GAP 3/4 in.
- 2 TYPE X GYPSUM BOARDS 5/8 in. EA.
- NORDIC X-LAM 6-7/8 in.
- Z-CHANNELS (26 GAUGE) 1-3/8 in. @ 16 in. O.C.
 INSTALLED VERTICALLY
- 1 ROW OF FIBERGLASS INSULATION OF TYPE "ROSE FIBERGLAS ECOTOUCH" 1-1/2 in.
- 2 TYPE X GYPSUM BOARDS 5/8 in. EA.

Architecture, Assembly

Partition

NS-DA2114

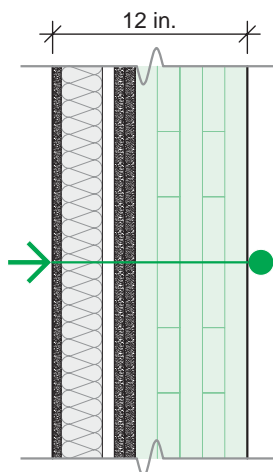

P15

Fire-resistance rating	FRR ^(a)	2.5 h / 1.5 h
------------------------	--------------------	---------------

Thermal resistance	RSI / R	n.a. / n.a.
--------------------	---------	-------------

Acoustic ratings	STC / FSTC	62 / n.a.
	IIC / FIIC	n.a. / n.a.

a) The fire-resistance ratings on each side of the partition are based on an effective length of 10 feet and on a concentric uniform load of 32,150 plf.

- 1 TYPE C GYPSUM BOARD 1/2 in.
- METAL STUDS (26 GAUGE) 1-1/4 in. X 2-1/2 in. @ 16 in. O.C.
- 1 ROW OF STONE WOOL INSULATION OF TYPE "ROXUL AFB" 2-1/2 in.
- AIR GAP 3/4 in.
- 2 TYPE X GYPSUM BOARDS 5/8 in. EA.
- NORDIC X-LAM 6-7/8 in.

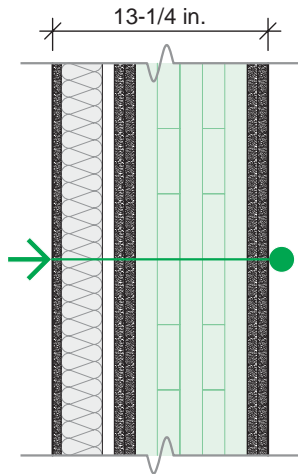

P16

Fire-resistance rating	FRR ^(a)	2.5 h / 2.5 h
Thermal resistance	RSI / R	n.a. / n.a.
Acoustic ratings	STC / FSTC	61 / n.a.
	IIC / FIIC	n.a. / n.a.

a) The fire-resistance ratings on each side of the partition are based on an effective length of 10 feet and on a concentric uniform load of 32,150 plf.

- 1 TYPE C GYPSUM BOARD 1/2 in.
- METAL STUDS (26 GAUGE) 1-1/4 in. X 2-1/2 in. @ 16 in. O.C.
- 1 ROW OF STONE WOOL INSULATION OF TYPE "ROXUL AFB" 2-1/2 in.
- AIR GAP 3/4 in.
- 2 TYPE X GYPSUM BOARDS 5/8 in. EA.
- NORDIC X-LAM 6-7/8 in.
- 2 TYPE X GYPSUM BOARDS 5/8 in. EA.

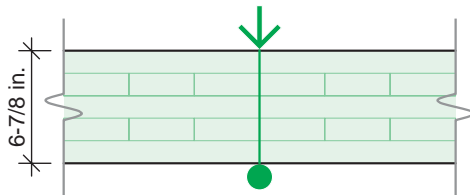

F1

Fire-resistance rating	FRR ^(a)	1.5 h
Thermal resistance	RSI / R	n.a. / n.a.
Acoustic ratings	STC / FSTC	39 / n.a.
	IIC / FIIC	27 / n.a.

a) The fire-resistance rating is based on a span of 18 feet and on a uniform load of 90 psf.

- NORDIC X-LAM 6-7/8 in.

Architecture, Assembly

Floor

NS-DA2201

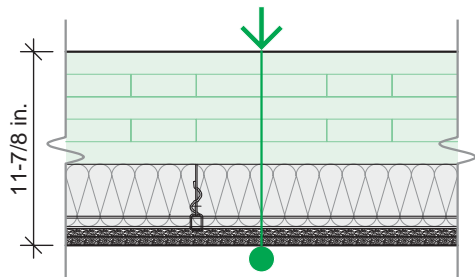

F2

Fire-resistance rating	FRR ^(a)	2 h
Thermal resistance	RSI / R	n.a. / n.a.
	STC ^(b) / FSTC	64 / n.a.
Acoustic ratings	IIC ^(b) / FIIC	59 / n.a.

a) The fire-resistance rating is based on a span of 18 feet and on a uniform load of 90 psf.

b) Composition and acoustic performance taken from the CLT Handbook – Canadian Edition (FPIInnovations, 2011). Acoustic performance based on a CLT thickness of 146 mm (5-3/4 in.).

- NORDIC X-LAM 6-7/8 in.
- SUSPENDED CEILING:
 - RESILIENT METALLIC HANGERS 4 in.
 - METAL TRACKS @ 16 in. O.C. MIN
 - SOUNDPROOFING MATERIAL 4 in.
- 2 TYPE X GYPSUM BOARDS 1/2 in. EA.

Architecture, Assembly

Floor

NS-DA2202

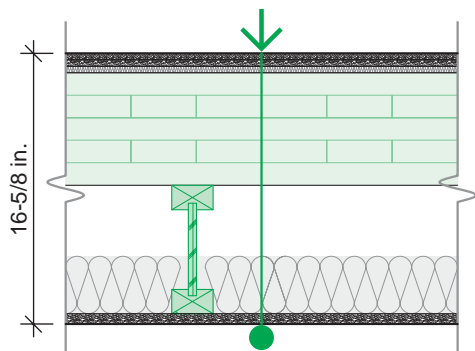

F3

Fire-resistance rating	FRR ^(a)	2 h
Thermal resistance	RSI / R	n.a. / n.a.
	STC / FSTC	n.a. / n.a.
Acoustic ratings	IIC / FIIC	n.a. / n.a.

a) The fire-resistance rating is based on a span of 18 feet and on a uniform load of 90 psf.

- UNDERLAY OF TYPE "FERMACELL 2E32" 1-1/4 in. OR "PERMABASE" WITH "SONOPAN"
- NORDIC X-LAM 6-7/8 in.
- NORDIC JOIST 7-7/8 in. @ 24 in. O.C.
- SOUNDPROOFING MATERIAL 3-1/2 in.
- 1 TYPE X GYPSUM BOARD 5/8 in.

Architecture, Assembly

Floor

NS-DA2203

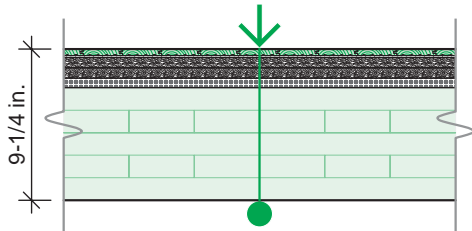

F4

Fire-resistance rating	FRR ^(a)	1.5 h
Thermal resistance	RSI / R	n.a. / n.a.
Acoustic ratings	STC / FSTC	n.a. / 47
	IIC / FIIC	n.a. / 46

a) The fire-resistance rating is based on a span of 18 feet and on a uniform load of 90 psf.

- FLOATING FLOOR 3/8 in.
- UNDERLAY OF TYPE "INSONOBOIS" 1/8 in.
- 2 UNDERLAYS OF TYPE "FIBEROCK" 5/8 in. EA.
- UNDERLAY OF TYPE "INSONOMAT" 5/8 in.
- NORDIC X-LAM 6-7/8 in.

Architecture, Assembly

Floor

NS-DA2204

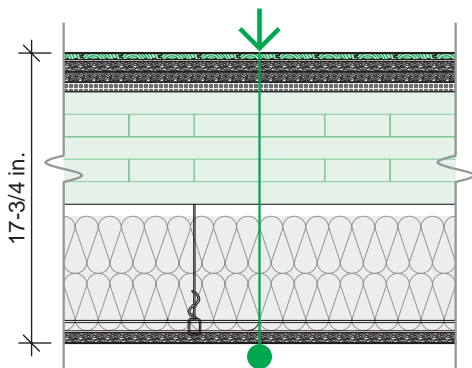

F5

Fire-resistance rating	FRR ^(a)	2 h
Thermal resistance	RSI / R	n.a. / n.a.
Acoustic ratings	STC / FSTC	n.a. / 59
	IIC / FIIC	n.a. / 61

a) The fire-resistance rating is based on a span of 18 feet and on a uniform load of 90 psf.

- FLOATING FLOOR 3/8 in.
- UNDERLAY OF TYPE "INSONOBOIS" 1/8 in.
- 2 FLOOR BACKERBOARDS OF TYPE "FIBEROCK" 5/8 in. EA.
- UNDERLAY OF TYPE "INSONOMAT" 5/8 in.
- NORDIC X-LAM 6-7/8 in.
- SUSPENDED CEILING:
 - RESILIENT METALLIC HANGERS 7-7/8 in. @ 48 in. O.C.
 - METAL TRACKS @ 24 in. O.C.
 - 2 ROWS OF STONE WOOL INSULATION OF TYPE "ROXUL" (2.5 pcf) 3-1/2 in. EA.
- 1 TYPE X GYPSUM BOARD 5/8 in.

Architecture, Assembly

Floor

NS-DA2205

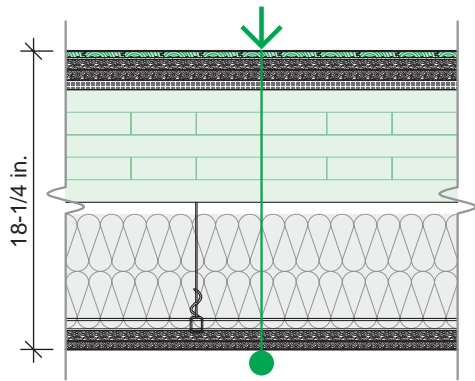

F6

Fire-resistance rating	FRR ^(a)	2 h
Thermal resistance	RSI / R	n.a. / n.a.
	STC / FSTC	n.a. / 58
Acoustic ratings	IIC / FIIC	n.a. / 60

a) The fire-resistance rating is based on a span of 18 feet and on a uniform load of 90 psf.

- FLOATING FLOOR 3/8 in.
- UNDERLAY OF TYPE "INSONOBOIS" 1/8 in.
- 2 FLOOR BACKERBOARDS OF TYPE "FIBEROCK" 5/8 in. EA.
- UNDERLAY OF TYPE "INSONOMAT" 5/8 in.
- NORDIC X-LAM 6-7/8 in.
- SUSPENDED CEILING:
 - RESILIENT METALLIC HANGERS 7-7/8 in. @ 48 in. O.C.
 - METAL TRACKS @ 24 in. O.C.
 - 2 ROWS OF STONE WOOL INSULATION OF TYPE "ROXUL" (2.5 pcf) 3-1/2 in. EA.
- 1 TYPE X GYPSUM BOARD 5/8 in.
- 1 REGULAR GYPSUM BOARD 1/2 in.

Architecture, Assembly

Floor

NS-DA2206

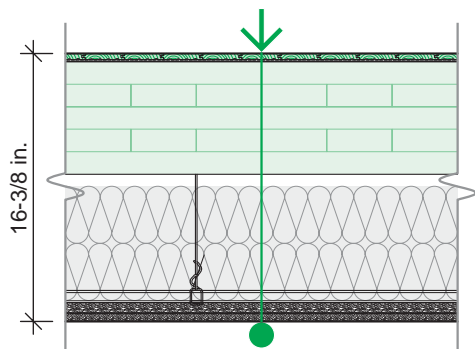

F7

Fire-resistance rating	FRR ^(a)	2 h
Thermal resistance	RSI / R	n.a. / n.a.
	STC / FSTC	n.a. / 54
Acoustic ratings	IIC / FIIC	n.a. / 56

a) The fire-resistance rating is based on a span of 18 feet and on a uniform load of 90 psf.

- FLOATING FLOOR 3/8 in.
- UNDERLAY OF TYPE "INSONOBOIS" 1/8 in.
- NORDIC X-LAM 6-7/8 in.
- SUSPENDED CEILING:
 - RESILIENT METALLIC HANGERS 7-7/8 in. @ 48 in. O.C.
 - METAL TRACKS @ 24 in. O.C.
 - 2 ROWS OF STONE WOOL INSULATION OF TYPE "ROXUL" (2.5 pcf) 3-1/2 in. EA.
- 1 TYPE X GYPSUM BOARD 5/8 in.
- 1 REGULAR GYPSUM BOARD 1/2 in.

Architecture, Assembly

Floor

NS-DA2207

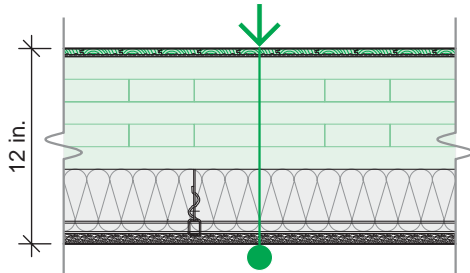

F8

Fire-resistance rating	FRR ^(a)	2 h
Thermal resistance	RSI / R	n.a. / n.a.
Acoustic ratings	STC / FSTC	n.a. / 53
	IIC / FIIC	n.a. / 52

a) The fire-resistance rating is based on a span of 18 feet and on a uniform load of 90 psf.

- FLOATING FLOOR 3/8 in.
- UNDERLAY OF TYPE "INSONOBOIS" 1/8 in.
- NORDIC X-LAM 6-7/8 in.
- SUSPENDED CEILING:
 - RESILIENT METALLIC HANGERS 4 in. @ 48 in. O.C.
 - METAL TRACKS @ 24 in. O.C.
 - 1 ROW OF STONE WOOL INSULATION OF TYPE "ROXUL" (2.5 pcf) 3-1/2 in. EA.
- 1 TYPE X GYPSUM BOARD 5/8 in.

Architecture, Assembly

Floor

NS-DA2208

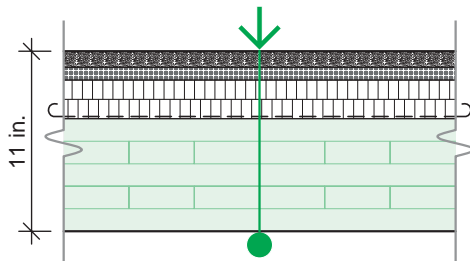

F9

Fire-resistance rating	FRR ^(a)	1.5 h
Thermal resistance	RSI / R	n.a. / n.a.
Acoustic ratings	STC ^(b) / FSTC	62 / n.a.
	IIC ^(b) / FIIC	59 / n.a.

a) The fire-resistance rating is based on a span of 18 feet and on a uniform load of 90 psf.

b) Composition and acoustic performance taken from the CLT Handbook – U.S. Edition (FPIInnovations, 2013). Acoustic performance based on a CLT thickness of 135 mm (5-5/16 in.).

- GYPSUM FIBERBOARD OF TYPE "FERMACELL" 1 in.
- UNDERLAY OF TYPE "ISOVER EP3" 3/4 in.
- 2 LAYERS OF PELLETS AND HONEYCOMB CORE OF TYPE "FERMACELL" 1-1/4 in. EA.
- KRAFT PAPER UNDERLAY
- NORDIC X-LAM 6-7/8 in.

Architecture, Assembly

Floor

NS-DA2209

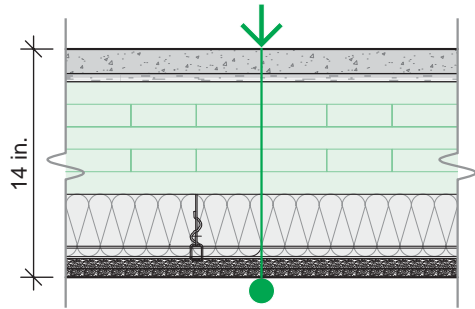

F10

Fire-resistance rating	FRR ^(a)	2 h
Thermal resistance	RSI / R	n.a. / n.a.
Acoustic ratings	STC / FSTC	n.a. / 61
	IIC / FIIC	n.a. / 50

a) The fire-resistance rating is based on a span of 18 feet and on a uniform load of 90 psf.

- CONCRETE TOPPING (125 pcf) 1-1/2 in.
- WOOD FIBER ACOUSTIC PANEL OF TYPE "BP ECO-LOGICAL" 1/2 in.
- NORDIC X-LAM 6-7/8 in.
- SUSPENDED CEILING:
 - RESILIENT METALLIC HANGERS 4 in. @ 48 in. O.C.
 - METAL TRACKS @ 24 in. O.C.
 - 1 ROW OF STONE WOOL INSULATION OF TYPE "ROXUL" (2.5 pcf) 3-1/2 in.
- 1 TYPE X GYPSUM BOARD 5/8 in.
- 1 REGULAR GYPSUM BOARD 1/2 in.

Architecture, Assembly

Floor

NS-DA2210

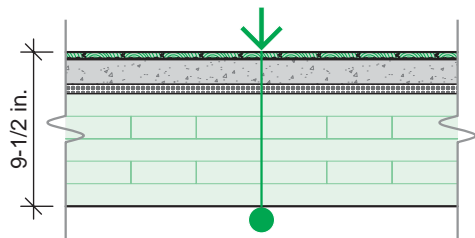

F11

Fire-resistance rating	FRR ^(a)	1.5 h
Thermal resistance	RSI / R	n.a. / n.a.
Acoustic ratings	STC / FSTC	55 / n.a.
	IIC / FIIC	51 / n.a.

a) The fire-resistance rating is based on a span of 18 feet and on a uniform load of 90 psf.

- ENGINEERED WOOD FLOOR 3/8 in.
- UNDERLAY OF TYPE "ROBERTS SOFT STRIDE" 1/8 in.
- CONCRETE TOPPING 1-1/2 in.
- UNDERLAY OF TYPE "INSONOMAT" 5/8 in.
- NORDIC X-LAM 6-7/8 in.

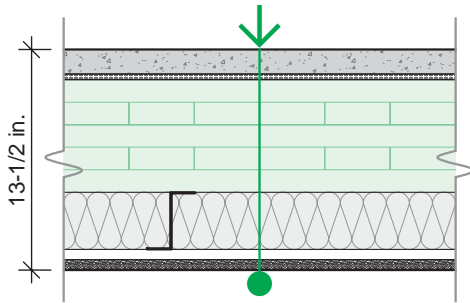

F12

Fire-resistance rating	FRR ^(a)	2 h
Thermal resistance	RSI / R	n.a. / n.a.
Acoustic ratings	STC / FSTC	70 / n.a.
	IIC / FIIC	56 / n.a.

a) The fire-resistance rating is based on a span of 18 feet and on a uniform load of 90 psf.

- CONCRETE TOPPING 1-1/2 in.
- UNDERLAY OF TYPE "OWENS CORNING QUIETUDE" 3/8 in.
- NORDIC X-LAM 6-7/8 in.
- Z-CHANNELS (26 GAUGE) 3-1/2 in. @ 24 in. O.C.
- 1 ROW OF FIBERGLASS INSULATION OF TYPE "ROSE FIBERGLAS ECOTOUCH" 3-5/8 in.
- FURRING CHANNELS 5/8 in. @ 16 in. O.C.
- 1 TYPE X GYPSUM BOARD 5/8 in.

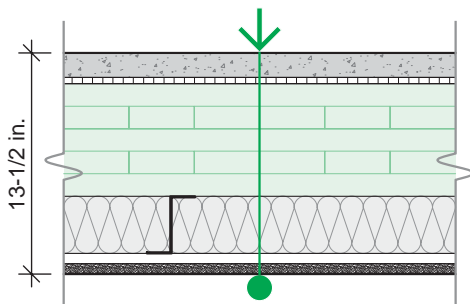

F13

Fire-resistance rating	FRR ^(a)	2 h
Thermal resistance	RSI / R	n.a. / n.a.
Acoustic ratings	STC / FSTC	69 / n.a.
	IIC / FIIC	54 / n.a.

a) The fire-resistance rating is based on a span of 18 feet and on a uniform load of 90 psf.

- CONCRETE TOPPING 1-1/2 in.
- TAR FIBERBOARD 3/8 in.
- NORDIC X-LAM 6-7/8 in.
- Z-CHANNELS (26 GAUGE) 3-1/2 in. @ 24 in. O.C.
- 1 ROW OF FIBERGLASS INSULATION OF TYPE "ROSE FIBERGLAS ECOTOUCH" 3-5/8 in.
- FURRING CHANNELS 5/8 in. @ 16 in. O.C.
- 1 TYPE X GYPSUM BOARD 5/8 in.

Architecture, Assembly

Floor

NS-DA2213

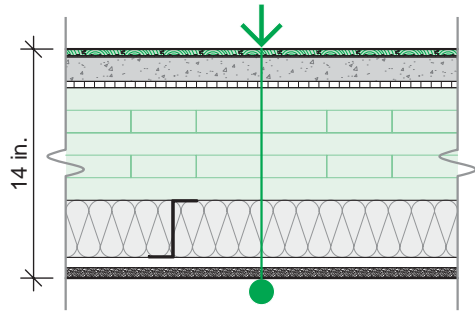

F14

Fire-resistance rating	FRR ^(a)	2 h
Thermal resistance	RSI / R	n.a. / n.a.
	STC / FSTC	69 / n.a.
Acoustic ratings	IIC / FIIC	58 / n.a.

a) The fire-resistance rating is based on a span of 18 feet and on a uniform load of 90 psf.

- ENGINEERED WOOD FLOOR 3/8 in.
- UNDERLAY OF TYPE "ROBERTS SOFT STRIDE" 1/8 in.
- CONCRETE TOPPING 1-1/2 in.
- TAR FIBERBOARD 3/8 in.
- NORDIC X-LAM 6-7/8 in.
- Z-CHANNELS (26 GAUGE) 3-1/2 in. @ 24 in. O.C.
- 1 ROW OF FIBERGLASS INSULATION OF TYPE "ROSE FIBERGLAS ECOTOUCH" 3-5/8 in.
- FURRING CHANNELS 5/8 in. @ 16 in. O.C.
- 1 TYPE X GYPSUM BOARD 5/8 in.

Architecture, Assembly

Floor

NS-DA2214

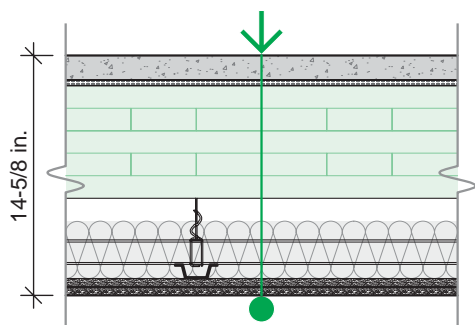

F15

Fire-resistance rating	FRR ^(a)	1.5 h
Thermal resistance	RSI / R	n.a. / n.a.
	STC / FSTC	72 / n.a.
Acoustic ratings	IIC / FIIC	65 / n.a.

a) The fire-resistance rating is based on a span of 18 feet and on a uniform load of 90 psf.

- CONCRETE TOPPING 1-1/2 in.
- UNDERLAY OF TYPE "OWENS CORNING QUIÉTUDE" 3/8 in.
- NORDIC X-LAM 6-7/8 in.
- SUSPENDED CEILING:
 - METALLIC HANGERS 2-1/2 in.
 - CHANNEL IRONS 1-1/2 in. @ 48 in. O.C.
 - FURRING CHANNELS 7/8 in. @ 16 in. O.C.
- 1 ROW OF FIBERGLASS INSULATION OF TYPE "ROSE FIBERGLAS ECOTOUCH" 3-5/8 in.
- 2 TYPE C GYPSUM BOARDS 1/2 in. EA.

Architecture, Assembly

Floor

NS-DA2215

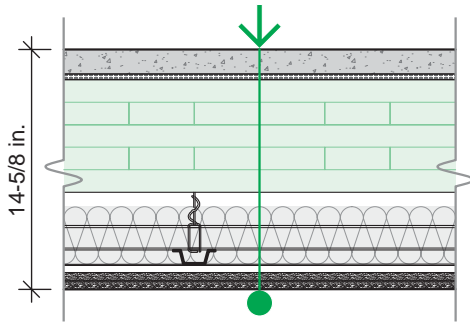

F16

Fire-resistance rating	FRR ^(a)	1.5 h
Thermal resistance	RSI / R	n.a. / n.a.
Acoustic ratings	STC / FSTC	73 / n.a.
	IIC / FIIC	66 / n.a.

a) The fire-resistance rating is based on a span of 18 feet and on a uniform load of 90 psf.

- CONCRETE TOPPING 1-1/2 in.
- UNDERLAY OF TYPE "OWENS CORNING QUIÉTUDE" 3/8 in.
- NORDIC X-LAM 6-7/8 in.
- SUSPENDED CEILING:
 - METALLIC HANGERS 2 in.
 - CHANNEL IRONS 1-1/2 in. @ 48 in. O.C.
 - FURRING CHANNELS 7/8 in. @ 16 in. O.C.
 - 1 ROW OF FIBERGLASS INSULATION OF TYPE "ROSE FIBERGLAS ECOTOUCH" 3-5/8 in.
- RESILIENT CHANNELS 1/2 in. @ 24 in. O.C.
- 2 TYPE C GYPSUM BOARDS 1/2 in. EA.

Architecture, Assembly

Floor

NS-DA2216

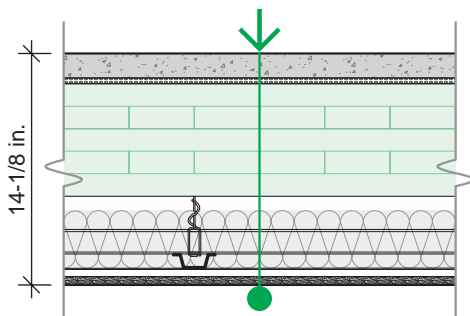

F17

Fire-resistance rating	FRR ^(a)	1.5 h
Thermal resistance	RSI / R	n.a. / n.a.
Acoustic ratings	STC / FSTC	72 / n.a.
	IIC / FIIC	62 / n.a.

a) The fire-resistance rating is based on a span of 18 feet and on a uniform load of 90 psf.

- CONCRETE TOPPING 1-1/2 in.
- UNDERLAY OF TYPE "OWENS CORNING QUIÉTUDE" 3/8 in.
- NORDIC X-LAM 6-7/8 in.
- SUSPENDED CEILING:
 - METALLIC HANGERS 2 in.
 - CHANNEL IRONS 1-1/2 in. @ 48 in. O.C.
 - FURRING CHANNELS 7/8 in. @ 16 in. O.C.
 - 1 ROW OF FIBERGLASS INSULATION OF TYPE "ROSE FIBERGLAS ECOTOUCH" 3-5/8 in.
- RESILIENT CHANNELS 1/2 in. @ 24 in. O.C.
- 1 TYPE C GYPSUM BOARD 1/2 in.

Architecture, Assembly

Floor

NS-DA2217

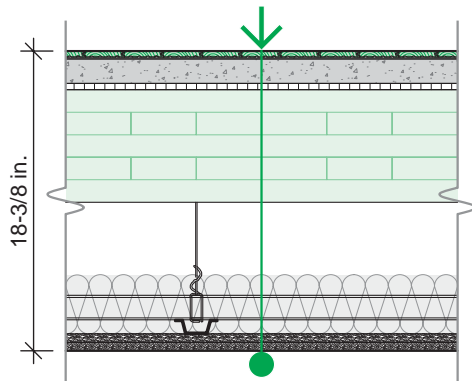

F18

Fire-resistance rating	FRR ^(a)	1.5 h
Thermal resistance	RSI / R	n.a. / n.a.
	STC ^(b) / FSTC	75 / n.a.
Acoustic ratings	IIC ^(b) / FIIC	66 / n.a.

- a) The fire-resistance rating is based on a span of 18 feet and on a uniform load of 90 psf.
 b) Acoustic performance based on a CLT thickness of 131 mm (5-1/8 in.).

- FLOATING FLOOR 3/8 in.
- UNDERLAY OF TYPE "ACOUSTITECH PREMIUM" 1/8 in.
- PREFABRICATED CONCRETE TOPPING 1-1/2 in.
- TAR FIBERBOARD 3/8 in.
- NORDIC X-LAM 6-7/8 in.
- SUSPENDED CEILING:
 - METALLIC HANGERS 5-3/4 in.
 - CHANNEL IRONS 1-1/2 in. @ 48 in. O.C.
 - FURRING CHANNELS 7/8 in. @ 16 in. O.C.
 - 1 ROW OF FIBERGLASS INSULATION OF TYPE "ROSE FIBERGLAS ECOTOUCH" 3-5/8 in.
- 2 TYPE C GYPSUM BOARDS 1/2 in. EA.

Architecture, Assembly

Floor

NS-DA2219

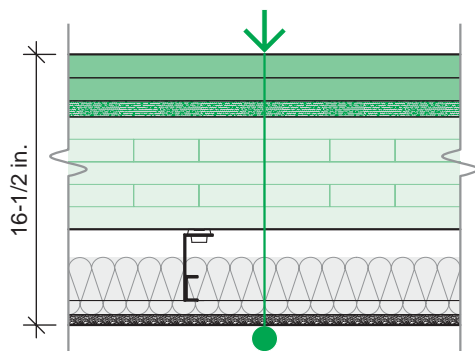

F20

Fire-resistance rating	FRR ^(a)	2 h
Thermal resistance	RSI / R	n.a. / n.a.
	STC / FSTC	61 / n.a.
Acoustic ratings	IIC / FIIC	55 / n.a.

- a) The fire-resistance rating is based on a span of 18 feet and on a uniform load of 90 psf.

- 2 ROWS OF PANELS OF TYPE "HUBER ENGINEERED WOOD ADVANTECH" 1-3/8 in. EA.
- UNDERLAY OF TYPE "GENIEMAT FF" 1 in.
- NORDIC X-LAM 6-7/8 in.
- SUSPENDED CEILING:
 - BRACKETS OF TYPE "GENIECLIP LB" 4-3/8 in.
 - CHANNEL IRONS 1-1/2 in. @ 48 in. O.C. FIXED AT THE BOTTOM OF THE BRACKETS
 - FURRING CHANNELS 7/8 in. @ 24 in. O.C.
 - 1 ROW OF FIBERGLASS INSULATION OF TYPE "JOHNS MANVILLE UNFACED BATTS R13" 3-1/2 in.
- 1 TYPE X GYPSUM BOARD 5/8 in.

Architecture, Assembly

Floor

NS-DA2220

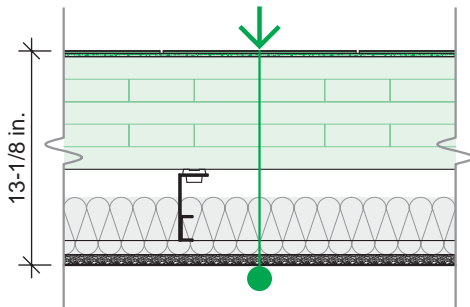

F21

Fire-resistance rating	FRR ^(a)	2 h
Thermal resistance	RSI / R	n.a. / n.a.
Acoustic ratings	STC / FSTC	58 / n.a.
	IIC / FIIC	58 / n.a.

a) The fire-resistance rating is based on a span of 18 feet and on a uniform load of 90 psf.

- VINYL TILES FLOORING 1/8 in.
- UNDERLAY OF TYPE "GENIEMAT RST05" 1/4 in.
- NORDIC X-LAM 6-78 in.
- SUSPENDED CEILING:
 - BRACKETS OF TYPE "GENIECLIP LB" 4-3/8 in.
 - CHANNEL IRONS 1-1/2 in. @ 48 in. O.C. FIXED AT THE BOTTOM OF THE BRACKETS
 - FURRING CHANNELS 7/8 in. @ 24 in. O.C.
 - 1 ROW OF FIBERGLASS INSULATION OF TYPE "JOHNS MANVILLE UNFACED BATTS R13" 3-1/2 in.
- 1 TYPE X GYPSUM BOARD 5/8 in.

Architecture, Assembly

Floor

NS-DA2221

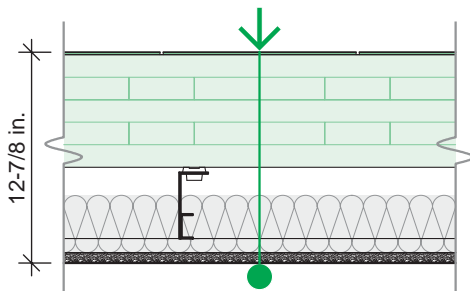

F22

Fire-resistance rating	FRR ^(a)	2 h
Thermal resistance	RSI / R	n.a. / n.a.
Acoustic ratings	STC / FSTC	57 / n.a.
	IIC / FIIC	54 / n.a.

a) The fire-resistance rating is based on a span of 18 feet and on a uniform load of 90 psf.

- VINYL TILES FLOORING 1/8 in.
- NORDIC X-LAM 6-7/8 in.
- SUSPENDED CEILING:
 - BRACKETS OF TYPE "GENIECLIP LB" 4-3/8 in.
 - CHANNEL IRONS 1-1/2 in. @ 48 in. O.C. FIXED AT THE BOTTOM OF THE BRACKETS
 - FURRING CHANNELS 7/8 in. @ 24 in. O.C.
 - 1 ROW OF FIBERGLASS INSULATION OF TYPE "JOHNS MANVILLE UNFACED BATTS R13" 3-1/2 in.
- 1 TYPE X GYPSUM BOARD 5/8 in.

Architecture, Assembly

Floor

NS-DA2222

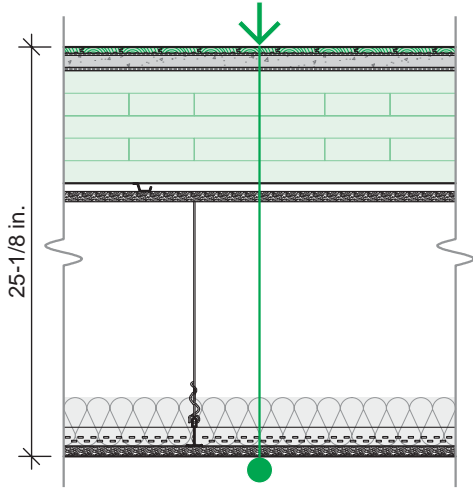

F23

Fire-resistance rating	FRR ^(a)	2.5 h
Thermal resistance	RSI / R	n.a. / n.a.
	STC / FSTC	n.a. / 54
Acoustic ratings	IIC / FIIC	n.a. / 53

a) The fire-resistance rating is based on a span of 18 feet and on a uniform load of 90 psf.

- FLOATING FLOOR 3/8 in.
- UNDERLAY OF TYPE "INSONOBOIS" 1/8 in.
- TOPPING OF TYPE "MAXXON GYP-CRETE" (128 pcf) 3/4 in.
- ENTANGLED FILAMENT MAT OF TYPE "MAXXON ACOUSTI-MAT 1" 1/4 in.
- NORDIC X-LAM 6-7/8 in.
- RESILIENT CHANNELS 1/2 in. @ 24 in. O.C.
- 1 TYPE X GYPSUM BOARD OF TYPE "QUIETROCK" 5/8 in.
- SUSPENDED DRYWALL GRID SYSTEM OF TYPE "ARMSTRONG":
 - METALLIC HANGERS 15 in.
 - T-CHANNELS 1-5/8 in. @ 48 in. O.C.
- 1 ROW OF STONE WOOL INSULATION OF TYPE "ROXUL" (2.5 pcf) 3 in.
- 1 TYPE X GYPSUM BOARD 5/8 in.

Architecture, Assembly

Floor

NS-DA2223

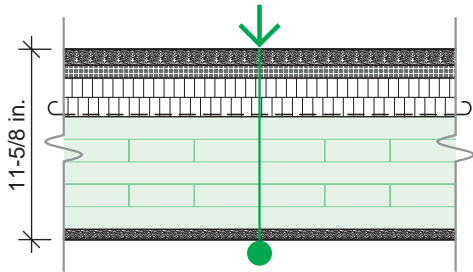

F24

Fire-resistance rating	FRR ^(a)	2 h
Thermal resistance	RSI / R	n.a. / n.a.
	STC ^(b) / FSTC	62 / n.a.
Acoustic ratings	IIC ^(b) / FIIC	59 / n.a.

a) The fire-resistance rating is based on a span of 18 feet and on a uniform load of 90 psf.

b) Composition and acoustic performance taken from the CLT Handbook – U.S. Edition (FPInnovations, 2013). Acoustic performance based on a CLT thickness of 135 mm (5-5/16 in.).

- GYPSUM FIBERBOARD OF TYPE "FERMACELL" 1 in.
- UNDERLAY OF TYPE "ISOVER EP3" 3/4 in.
- 2 LAYERS OF PELLETS AND HONEYCOMB CORE OF TYPE "FERMACELL" 1-1/4 in. EA.
- KRAFT PAPER UNDERLAY
- NORDIC X-LAM 6-7/8 in.
- 1 TYPE X GYPSUM BOARD 5/8 in.

Architecture, Assembly

Floor

NS-DA2224

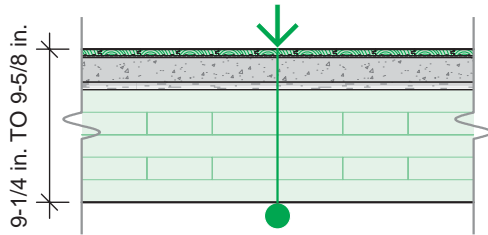

F25

Fire-resistance rating	FRR ^(a)	1.5 h
Thermal resistance	RSI / R	n.a. / n.a.
Acoustic ratings	STC / FSTC ^(b)	n.a. / > 50
	IIC / FIIC ^(b)	n.a. / > 50

- a) The fire-resistance rating is based on a span of 18 feet and on a uniform load of 90 psf.
- b) Composition and acoustic performance taken from the CLT Handbook – U.S. Edition (FPIInnovations, 2013). Acoustic performance based on a CLT thickness of 135 mm (5-5/16 in.).
- CARPET OR FLOATING FLOOR 3/8 in.
 - RESILIENT UNDERLAY (RUBBER OR FELT) 1/8 in.
 - TOPPING, AT LEAST 15.6 psf (I.E. CONCRETE OR OF TYPE "MAXXON GYP-CRETE")
 - RESILIENT UNDERLAY (RUBBER 3/8 in., FELT 3/4 in., OR WOOD FIBERBOARD 1/2 in.)
 - NORDIC X-LAM 6-7/8 in.

Architecture, Assembly

Floor

NS-DA2225

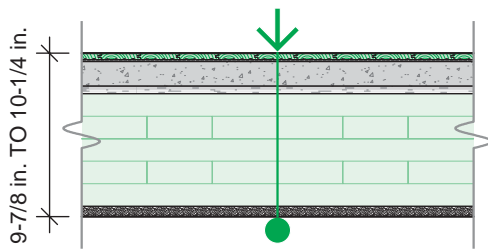

F26

Fire-resistance rating	FRR ^(a)	2 h
Thermal resistance	RSI / R	n.a. / n.a.
Acoustic ratings	STC / FSTC ^(b)	n.a. / > 50
	IIC / FIIC ^(b)	n.a. / > 50

- a) The fire-resistance rating is based on a span of 18 feet and on a uniform load of 90 psf.
- b) Composition and acoustic performance taken from the CLT Handbook – U.S. Edition (FPIInnovations, 2013). Acoustic performance based on a CLT thickness of 135 mm (5-5/16 in.).
- CARPET OR FLOATING FLOOR 3/8 in.
 - RESILIENT UNDERLAY (RUBBER OR FELT) 1/8 in.
 - TOPPING, AT LEAST 15.6 psf (I.E. CONCRETE OR OF TYPE "MAXXON GYP-CRETE")
 - RESILIENT UNDERLAY (RUBBER 3/8 in., FELT 3/4 in., OR WOOD FIBERBOARD 1/2 in.)
 - NORDIC X-LAM 6-7/8 in.
 - 1 TYPE X GYPSUM BOARD 5/8 in.

Architecture, Assembly

Floor

NS-DA2226

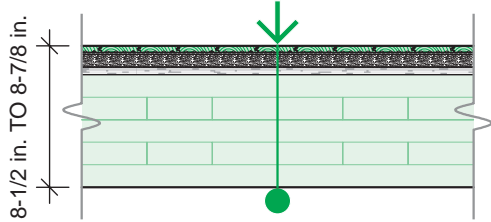

F27

Fire-resistance rating	FRR ^(a)	1.5 h
Thermal resistance	RSI / R	n.a. / n.a.
Acoustic ratings	STC / FSTC ^(b)	n.a. / > 45
	IIC / FIIC ^(b)	n.a. / > 45

- a) The fire-resistance rating is based on a span of 18 feet and on a uniform load of 90 psf.
- b) Composition and acoustic performance taken from the CLT Handbook – U.S. Edition (FPInnovations, 2013). Acoustic performance based on a CLT thickness of 135 mm (5-5/16 in.).

- CARPET OR FLOATING FLOOR 3/8 in.
- RESILIENT UNDERLAY (RUBBER OR FELT) 1/8 in.
- PREFABRICATED TOPPING, AT LEAST 5.1 psf (3/4 in. OF TYPE "FERMACELL" OR OF TYPE "FIBREROCK")
- RESILIENT UNDERLAY (RUBBER 3/8 in., FELT 3/4 in., OR WOOD FIBERBOARD 1/2 in.)
- NORDIC X-LAM 6-7/8 in.

Architecture, Assembly

Floor

NS-DA2227

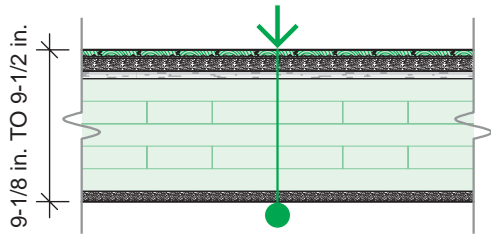

F28

Fire-resistance rating	FRR ^(a)	2 h
Thermal resistance	RSI / R	n.a. / n.a.
Acoustic ratings	STC / FSTC ^(b)	n.a. / > 45
	IIC / FIIC ^(b)	n.a. / > 45

- a) The fire-resistance rating is based on a span of 18 feet and on a uniform load of 90 psf.
- b) Composition and acoustic performance taken from the CLT Handbook – U.S. Edition (FPInnovations, 2013). Acoustic performance based on a CLT thickness of 135 mm (5-5/16 in.).

- CARPET OR FLOATING FLOOR 3/8 in.
- RESILIENT UNDERLAY (RUBBER OR FELT) 1/8 in.
- PREFABRICATED TOPPING, AT LEAST 5.1 psf (3/4 in. OF TYPE "FERMACELL" OR OF TYPE "FIBREROCK")
- RESILIENT UNDERLAY (RUBBER 3/8 in., FELT 3/4 in., OR WOOD FIBERBOARD 1/2 in.)
- NORDIC X-LAM 6-7/8 in.
- 1 TYPE X GYPSUM BOARD 5/8 in.

Architecture, Assembly

Floor

NS-DA2228

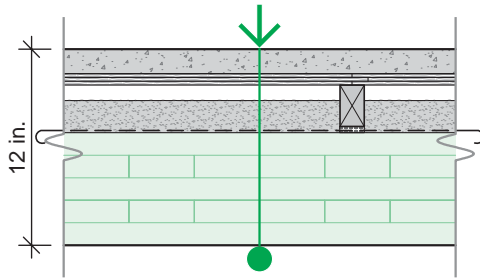

F29

Fire-resistance rating	FRR ^(a)	1.5 h
Thermal resistance	RSI / R	n.a. / n.a.
Acoustic ratings	STC ^(b) / FSTC	64 / n.a.
	IIC ^(b) / FIIC	53 / n.a.

- a) The fire-resistance rating is based on a span of 18 feet and on a uniform load of 90 psf.
 b) Acoustic performance based on a CLT thickness of 131 mm (5-1/8 in.).

- PREFABRICATED CONCRETE TOPPING 1-1/2 in.
- TONGUE AND GROOVE OSB SHEATHING 3/4 in.
- WOOD RAFTERS 2 in. X 3 in. @ 24 in. O.C.
- SILICA SAND (#71) 2 in.
- RUBBER MEMBRANE BANDS 3/8 in. UNDER RAFTERS
- POLYETHYLENE SHEETING 6 mil
- NORDIC X-LAM 6-7/8 in.

Architecture, Assembly

Floor

NS-DA2229

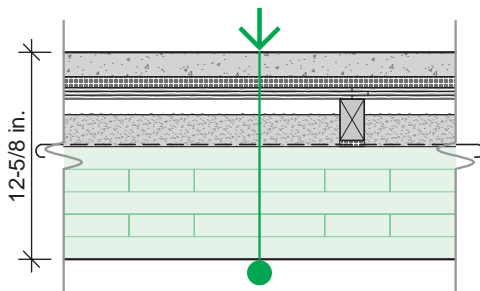

F30

Fire-resistance rating	FRR ^(a)	1.5 h
Thermal resistance	RSI / R	n.a. / n.a.
Acoustic ratings	STC ^(b) / FSTC	66 / n.a.
	IIC ^(b) / FIIC	60 / n.a.

- a) The fire-resistance rating is based on a span of 18 feet and on a uniform load of 90 psf.
 b) Acoustic performance based on a CLT thickness of 131 mm (5-1/8 in.).

- PREFABRICATED CONCRETE TOPPING 1-1/2 in.
- UNDERLAY OF TYPE "REGUPOL SONUS WAVE" 5/8 in.
- TONGUE AND GROOVE OSB SHEATHING 3/4 in.
- WOOD RAFTERS 2 in. X 3 in. @ 24 in. O.C.
- SILICA SAND (#71) 2 in.
- RUBBER MEMBRANE BANDS 3/8 in. UNDER RAFTERS
- POLYETHYLENE SHEETING 6 mil
- NORDIC X-LAM 6-7/8 in.

Architecture, Assembly

Floor

NS-DA2230

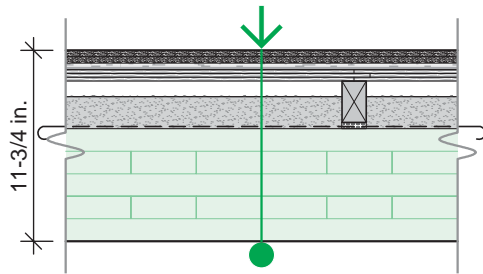

F31

Fire-resistance rating	FRR ^(a)	1.5 h
Thermal resistance	RSI / R	n.a. / n.a.
Acoustic ratings	STC ^(b) / FSTC	59 / n.a.
	IIC ^(b) / FIIC	53 / n.a.

- a) The fire-resistance rating is based on a span of 18 feet and on a uniform load of 90 psf.
 b) Acoustic performance based on a CLT thickness of 131 mm (5-1/8 in.).

- UNDERLAY OF TYPE "FERMACELL 2E31" 1-1/4 in.
- TONGUE AND GROOVE OSB SHEATHING 3/4 in.
- WOOD RAFTERS 2 in. X 3 in. @ 24 in. O.C.
- SILICA SAND (#71) 2 in.
- RUBBER MEMBRANE BANDS 3/8 in. UNDER RAFTERS
- POLYETHYLENE SHEETING 6 mil
- NORDIC X-LAM 6-7/8 in.

Architecture, Assembly

Floor

NS-DA2231

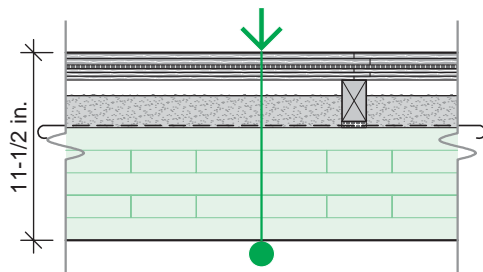

F32

Fire-resistance rating	FRR ^(a)	1.5 h
Thermal resistance	RSI / R	n.a. / n.a.
Acoustic ratings	STC ^(b) / FSTC	56 / n.a.
	IIC ^(b) / FIIC	50 / n.a.

- a) The fire-resistance rating is based on a span of 18 feet and on a uniform load of 90 psf.
 b) Acoustic performance based on a CLT thickness of 131 mm (5-1/8 in.).

- UNDERLAY OF TYPE "SONODECK INSULFLOOR" 1 in.
- TONGUE AND GROOVE OSB SHEATHING 3/4 in.
- WOOD RAFTERS 2 in. X 3 in. @ 24 in. O.C.
- SILICA SAND (#71) 2 in.
- RUBBER MEMBRANE BANDS 3/8 in. UNDER RAFTERS
- POLYETHYLENE SHEETING 6 mil
- NORDIC X-LAM 6-7/8 in.

Architecture, Assembly

Floor

NS-DA2232

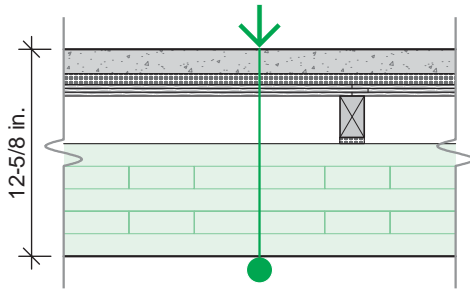

F33

Fire-resistance rating	FRR ^(a)	1.5 h
Thermal resistance	RSI / R	n.a. / n.a.
Acoustic ratings	STC ^(b) / FSTC	59 / n.a.
	IIC ^(b) / FIIC	54 / n.a.

- a) The fire-resistance rating is based on a span of 18 feet and on a uniform load of 90 psf.
 b) Acoustic performance based on a CLT thickness of 131 mm (5-1/8 in.).

- PREFABRICATED CONCRETE TOPPING 1-1/2 in.
- UNDERLAY OF TYPE "REGUPOL SONUS WAVE" 5/8 in.
- TONGUE AND GROOVE OSB SHEATHING 3/4 in.
- WOOD RAFTERS 2 in. X 3 in. @ 24 in. O.C.
- RUBBER MEMBRANE BANDS 3/8 in. UNDER RAFTERS
- NORDIC X-LAM 6-7/8 in.

Architecture, Assembly

Floor

NS-DA2233

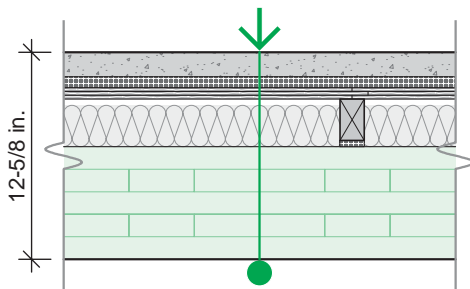

F34

Fire-resistance rating	FRR ^(a)	1.5 h
Thermal resistance	RSI / R	n.a. / n.a.
Acoustic ratings	STC ^(b) / FSTC	60 / n.a.
	IIC ^(b) / FIIC	54 / n.a.

- a) The fire-resistance rating is based on a span of 18 feet and on a uniform load of 90 psf.
 b) Acoustic performance based on a CLT thickness of 131 mm (5-1/8 in.).

- PREFABRICATED CONCRETE TOPPING 1-1/2 in.
- UNDERLAY OF TYPE "REGUPOL SONUS WAVE" 5/8 in.
- TONGUE AND GROOVE OSB SHEATHING 3/4 in.
- WOOD RAFTERS 2 in. X 3 in. @ 24 in. O.C.
- 1 ROW OF FIBERGLASS INSULATION 2-1/2 in.
- RUBBER MEMBRANE BANDS 3/8 in. UNDER RAFTERS
- NORDIC X-LAM 6-7/8 in.

Architecture, Assembly

Floor

NS-DA2235

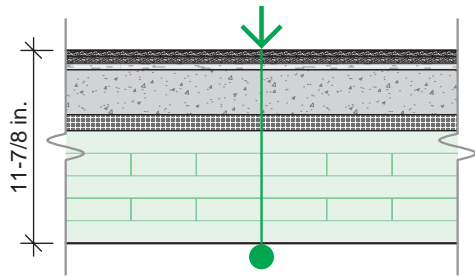

F36

Fire-resistance rating	FRR ^(a)	1.5 h
Thermal resistance	RSI / R	n.a. / n.a.
Acoustic ratings	STC ^(b) / FSTC	56 / n.a.
	IIC ^(b) / FIIC	52 / n.a.

- a) The fire-resistance rating is based on a span of 18 feet and on a uniform load of 90 psf.
 b) Acoustic performance based on a CLT thickness of 131 mm (5-1/8 in.).

- UNDERLAY OF TYPE "FERMACELL 2E31" 1-1/4 in.
- PREFABRICATED CONCRETE TOPPING (147 pcf) 2-3/4 in.
- UNDERLAY OF TYPE "REGUPOL SONUS WAVE" 1 in.
- NORDIC X-LAM 6-7/8 in.

Architecture, Assembly

Floor

NS-DA2236

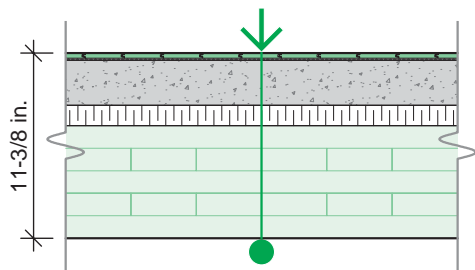

F37

Fire-resistance rating	FRR ^(a)	1.5 h
Thermal resistance	RSI / R	n.a. / n.a.
Acoustic ratings	STC ^(b) / FSTC	57 / n.a.
	IIC ^(b) / FIIC	51 / n.a.

- a) The fire-resistance rating is based on a span of 18 feet and on a uniform load of 90 psf.
 b) Acoustic performance based on a CLT thickness of 131 mm (5-1/8 in.).

- LAMINATED FLOORING 3/8 in.
- UNDERLAY OF TYPE "ACOUSTITECH PREMIUM" 1/8 in.
- PREFABRICATED CONCRETE TOPPING (147 pcf) 2-3/4 in.
- RIGID SHEATHING BOARD OF TYPE "ROXUL COMFORTBOARD IS" 1-1/4 in.
- NORDIC X-LAM 6-7/8 in.

Architecture, Assembly

Floor

NS-DA2237

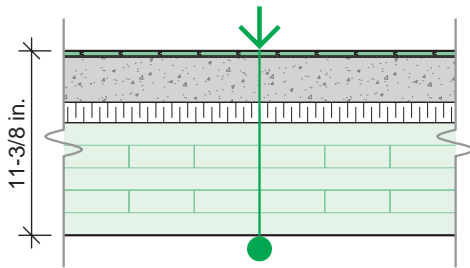

F38

Fire-resistance rating	FRR ^(a)	1.5 h
Thermal resistance	RSI / R	n.a. / n.a.
Acoustic ratings	STC ^(b) / FSTC	57 / n.a.
	IIC ^(b) / FIIC	51 / n.a.

- a) The fire-resistance rating is based on a span of 18 feet and on a uniform load of 90 psf.
- b) Acoustic performance based on a CLT thickness of 131 mm (5-1/8 in.).

- LAMINATED FLOORING 3/8 in.
- UNDERLAY OF TYPE "ROBERTS SOFT STRIDE" 1/8 in.
- PREFABRICATED CONCRETE TOPPING (147 pcf) 2-3/4 in.
- RIGID SHEATHING BOARD OF TYPE "ROXUL COMFORTBOARD IS" 1-1/4 in.
- NORDIC X-LAM 6-7/8 in.

Architecture, Assembly

Floor

NS-DA2238

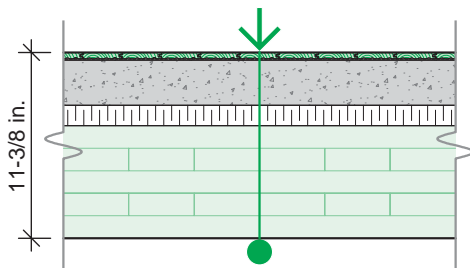

F39

Fire-resistance rating	FRR ^(a)	1.5 h
Thermal resistance	RSI / R	n.a. / n.a.
Acoustic ratings	STC ^(b) / FSTC	57 / n.a.
	IIC ^(b) / FIIC	51 / n.a.

- a) The fire-resistance rating is based on a span of 18 feet and on a uniform load of 90 psf.
- b) Acoustic performance based on a CLT thickness of 131 mm (5-1/8 in.).

- HARDWOOD FLOORING OF TYPE "TORLYS EVEREST PREMIER" 3/8 in.
- UNDERLAY OF TYPE "ROBERTS SOFT STRIDE" 1/8 in.
- PREFABRICATED CONCRETE TOPPING (147 pcf) 2-3/4 in.
- RIGID SHEATHING BOARD OF TYPE "ROXUL COMFORTBOARD IS" 1-1/4 in.
- NORDIC X-LAM 6-7/8 in.

Architecture, Assembly

Floor

NS-DA2239

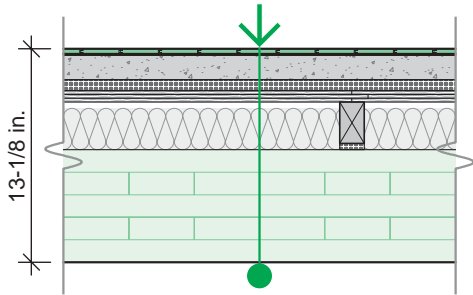

F40

Fire-resistance rating	FRR ^(a)	1.5 h
Thermal resistance	RSI / R	n.a. / n.a.
Acoustic ratings	STC ^(b) / FSTC	60 / n.a.
	IIC ^(b) / FIIC	58 / n.a.

- a) The fire-resistance rating is based on a span of 18 feet and on a uniform load of 90 psf.
 b) Acoustic performance based on a CLT thickness of 131 mm (5-1/8 in.).

- LAMINATED FLOORING 3/8 in.
- UNDERLAY OF TYPE "ROBERTS SOFT STRIDE" 1/8 in.
- PREFABRICATED CONCRETE TOPPING 1-1/2 in.
- UNDERLAY OF TYPE "REGUPOL SONUS WAVE" 5/8 in.
- TONGUE AND GROOVE OSB SHEATHING 3/4 in.
- WOOD RAFTERS 2 in. X 3 in. @ 24 in. O.C.
- 1 ROW OF FIBERGLASS INSULATION 2-1/2 in.
- RUBBER MEMBRANE BANDS 3/8 in. UNDER RAFTERS
- NORDIC X-LAM 6-7/8 in.

Architecture, Assembly

Roof

NS-DA2300

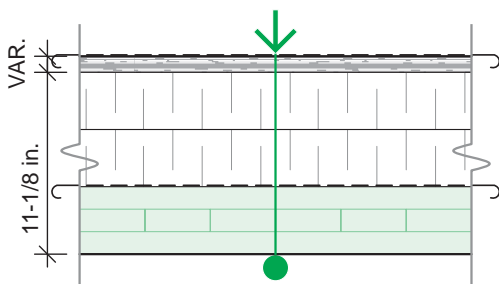

R1

Fire-resistance rating	FRR ^(a)	1 h
Thermal resistance	RSI / R	7.9 / 45
Acoustic ratings	STC / FSTC	n.a. / n.a.
	IIC / FIIC	n.a. / n.a.

- a) The fire-resistance rating is based on a span of 12 feet and on a uniform load of 80 psf.

- TWO-LAYER ELASTOMERIC MEMBRANE ROOFING
- ROOFING UNDERLAY (UP TO THE DESIGNER)
- 2 ROWS OF POLYISOCYANURATE INSULATION 3-1/2 in. EA.
- VAPOR BARRIER MEMBRANE
- NORDIC X-LAM 4-1/8 in.

Architecture, Assembly

Roof

NS-DA2301

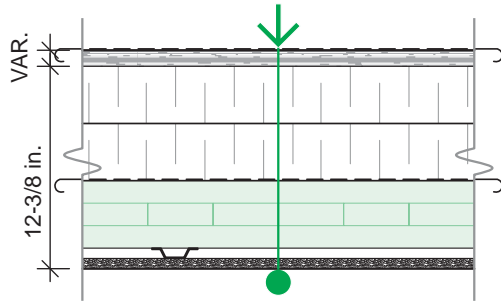

R2

Fire-resistance rating	FRR ^(a)	1.5 h
Thermal resistance	RSI / R	8.2 / 47
Acoustic ratings	STC / FSTC	n.a. / n.a.
	IIC / FIIC	n.a. / n.a.

a) The fire-resistance rating is based on a span of 12 feet and on a uniform load of 80 psf.

- TWO-LAYER ELASTOMERIC MEMBRANE ROOFING
- ROOFING UNDERLAY (UP TO THE DESIGNER)
- 2 ROWS OF POLYISOCYANURATE INSULATION 3-1/2 in. EA.
- VAPOR BARRIER MEMBRANE
- NORDIC X-LAM 4-1/8 in.
- FURRING CHANNELS 5/8 in. @ 16 in. O.C.
- 1 TYPE X GYPSUM BOARD 5/8 in.

Architecture, Assembly

Roof

NS-DA2302

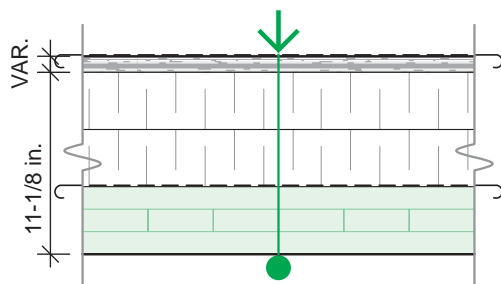

R3

Fire-resistance rating	FRR ^(a)	1 h
Thermal resistance	RSI / R	7.9 / 45
Acoustic ratings	STC / FSTC	n.a. / n.a.
	IIC / FIIC	n.a. / n.a.

a) The fire-resistance rating is based on a span of 12 feet and on a uniform load of 80 psf.

- THERMOPLASTIC POLYOLEFIN (TPO) MEMBRANE ROOFING
- ROOFING UNDERLAY (UP TO THE DESIGNER)
- 2 ROWS OF POLYISOCYANURATE INSULATION 3-1/2 in. EA.
- VAPOR BARRIER MEMBRANE
- NORDIC X-LAM 4-1/8 in.

Architecture, Assembly

Roof

NS-DA2303

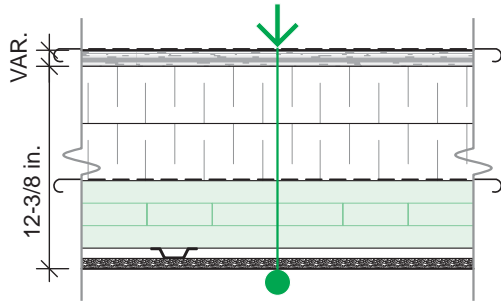

R4

Fire-resistance rating	FRR ^(a)	1.5 h
Thermal resistance	RSI / R	8.2 / 47
Acoustic ratings	STC / FSTC	n.a. / n.a.
	IIC / FIIC	n.a. / n.a.

a) The fire-resistance rating is based on a span of 12 feet and on a uniform load of 80 psf.

- THERMOPLASTIC POLYOLEFIN (TPO) MEMBRANE ROOFING
- ROOFING UNDERLAY (UP TO THE DESIGNER)
- 2 ROWS OF POLYISOCYANURATE INSULATION 3-1/2 in. EA.
- VAPOR BARRIER MEMBRANE
- NORDIC X-LAM 4-1/8 in.
- FURRING CHANNELS 5/8 in. @ 16 in. O.C.
- 1 TYPE X GYPSUM BOARD 5/8 in.

Architecture, Assembly

Roof

NS-DA2304

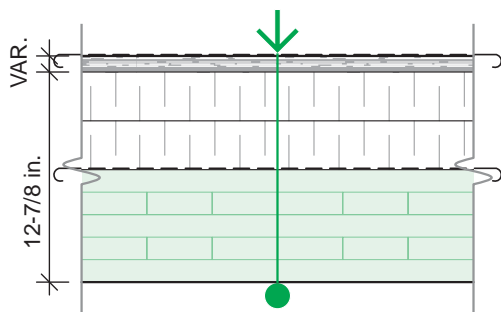

R5

Fire-resistance rating	FRR ^(a)	1.5 h
Thermal resistance	RSI / R	7.5 / 43
Acoustic ratings	STC / FSTC	n.a. / n.a.
	IIC / FIIC	n.a. / n.a.

a) The fire-resistance rating is based on a span of 18 feet and on a uniform load of 90 psf.

- TWO-LAYER ELASTOMERIC MEMBRANE ROOFING
- ROOFING UNDERLAY (UP TO THE DESIGNER)
- 2 ROWS OF POLYISOCYANURATE INSULATION 3 in. EA.
- VAPOR BARRIER MEMBRANE
- NORDIC X-LAM 6-7/8 in.

Architecture, Assembly

Roof

NS-DA2305

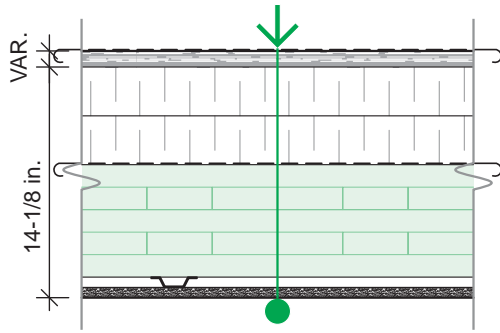

R6

Fire-resistance rating	FRR ^(a)	2 h
Thermal resistance	RSI / R	7.7 / 44
Acoustic ratings	STC / FSTC	n.a. / n.a.
	IIC / FIIC	n.a. / n.a.

a) The fire-resistance rating is based on a span of 18 feet and on a uniform load of 90 psf.

- TWO-LAYER ELASTOMERIC MEMBRANE ROOFING
- ROOFING UNDERLAY (UP TO THE DESIGNER)
- 2 ROWS OF POLYISOCYANURATE INSULATION 3 in. EA.
- VAPOR BARRIER MEMBRANE
- NORDIC X-LAM 6-7/8 in.
- FURRING CHANNELS 5/8 in. @ 16 in. O.C.
- 1 TYPE X GYPSUM BOARD 5/8 in.

Architecture, Assembly

Roof

NS-DA2306

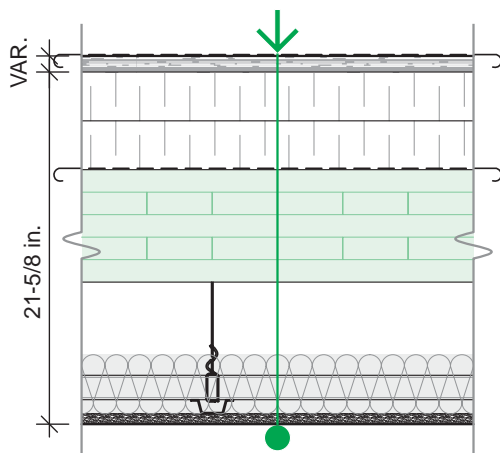

R7

Fire-resistance rating	FRR ^(a)	2 h
Thermal resistance	RSI / R	7.7 / 44
Acoustic ratings	STC / FSTC	n.a. / n.a.
	IIC / FIIC	n.a. / n.a.

a) The fire-resistance rating is based on a span of 18 feet and on a uniform load of 90 psf.

- TWO-LAYER ELASTOMERIC MEMBRANE ROOFING
- ROOFING UNDERLAY (UP TO THE DESIGNER)
- 2 ROWS OF POLYISOCYANURATE INSULATION 3 in. EA.
- VAPOR BARRIER MEMBRANE
- NORDIC X-LAM 6-7/8 in.
- SUSPENDED CEILING:
 - METALLIC HANGERS 5-3/4 in.
 - CHANNEL IRONS 1-1/2 in. @ 48 in. O.C.
 - FURRING CHANNELS 7/8 in. @ 16 in. O.C.
 - SOUNDPROOFING MATERIAL 3-5/8 in.
- 1 TYPE X GYPSUM BOARD 5/8 in.

Architecture, Assembly

Roof

NS-DA2307

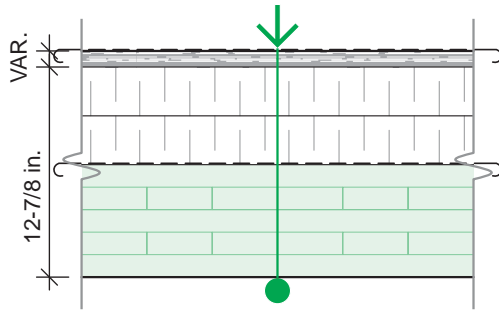

R8

Fire-resistance rating	FRR ^(a)	1.5 h
Thermal resistance	RSI / R	7.5 / 43
Acoustic ratings	STC / FSTC	n.a. / n.a.
	IIC / FIIC	n.a. / n.a.

a) The fire-resistance rating is based on a span of 18 feet and on a uniform load of 90 psf.

- THERMOPLASTIC POLYOLEFIN (TPO) MEMBRANE ROOFING
- ROOFING UNDERLAY (UP TO THE DESIGNER)
- 2 ROWS OF POLYISOCYANURATE INSULATION 3 in. EA.
- VAPOR BARRIER MEMBRANE
- NORDIC X-LAM 6-7/8 in.

Architecture, Assembly

Roof

NS-DA2308

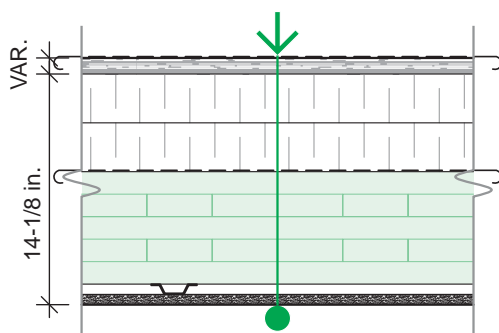

R9

Fire-resistance rating	FRR ^(a)	2 h
Thermal resistance	RSI / R	7.7 / 44
Acoustic ratings	STC / FSTC	n.a. / n.a.
	IIC / FIIC	n.a. / n.a.

a) The fire-resistance rating is based on a span of 18 feet and on a uniform load of 90 psf.

- THERMOPLASTIC POLYOLEFIN (TPO) MEMBRANE ROOFING
- ROOFING UNDERLAY (UP TO THE DESIGNER)
- 2 ROWS OF POLYISOCYANURATE INSULATION 3 in. EA.
- VAPOR BARRIER MEMBRANE
- NORDIC X-LAM 6-7/8 in.
- FURRING CHANNELS 5/8 in. @ 16 in. O.C.
- 1 TYPE X GYPSUM BOARD 5/8 in.

NORDIC

TECHNICAL GUIDE
NORDIC X-LAM

NS-GT6 

ASD

VERSION
2026-02-01

ADDITIONAL
INFORMATION

5

Software



Nordic Sizer

Nordic Sizer is a software program built to design individual structural elements (joists, beams, columns, studs, slabs, and panels) using the full range of Nordic engineered wood products.

Nordic Sizer software application analyzes and designs members for specified loads in accordance with CSA O86 (Canada) or NDS (United States) standard, and automatically checks load cases and load combinations in accordance with NBC (Canada) or IBC (United States). Features include floor vibration checks and fire resistance calculations.

For more information: <http://woodworks-software.com>

DOWNLOAD & INSTALL

Fill in the [form](http://contact.nordic.ca/en/nordic-sizer-software-request/) (contact.nordic.ca/en/nordic-sizer-software-request/) to receive instructions by email within the next business day.

For assistance, please contact the technical support at 514-871-8526, ext. 2 or tech@nordic.ca.

WOODWORKS SOFTWARE TUTORIALS

US Training Videos and User Guide

woodworks-software.com/support/support-us-edition/

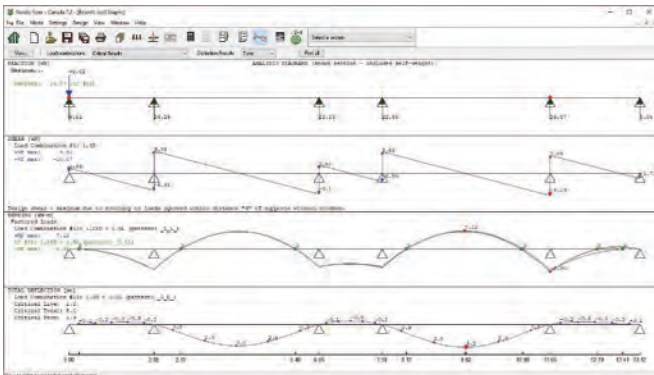

NORDIC STRUCTURES	COMPANY Aug. 12, 2020 15:47	PROJECT Beam1
	Design Check Calculation Sheet Nordic Sizer – Canada 7.2	

Loads:

Load	Type	Distribution	Pat-tern	Location [m]	Magnitude	Unit
				Start	End	
Load1	Dead	Full Area	No		2.72(1.00m)	kN/m2
Load2	Live	Full Area	Yes		1.90(1.00m)	kN/m2
Self-weight	Dead	Full UDL	No		0.72	kN/m

Maximum Reactions (kN), Bearing Resistances (kN) and Bearing Lengths (mm) :

	0	2.05	6.05	7.58	11.65	13.82 m
Unfactored:						
Dead	1.54	12.59		9.22	9.56	12.87
Live	1.79	7.04		7.14	7.28	7.19
Factored:						
Uplift	0.02					
Total	4.61	26.29		22.23	22.86	26.87
Bearing:						
Capacity						
Beam	161.54	282.46		305.35	304.13	282.38
Des ratio						
Beam	0.03	0.08		0.06	0.07	0.08
Load case	#24	#14		#25	#16	#29
Length	38*	76		76	76	38*
Min req'd	38*	76*		76*	76*	38*
KB	1.00	1.00		1.00	1.00	1.00
KB min	1.00	1.00		1.00	1.00	1.00
KD	1.00	0.87		0.94	0.94	0.87

*Minimum bearing length for panels is 38 mm for exterior supports and 76 mm for intermediate supports

Nordic X-Lam Floor Panel Architectural, E1 143-5S 143 mm (1000 mm width)
 Supports: All - Non-wood
 Total length: 13.858 m; Clear span: 2, 3.9, 1.5, 4, 2.1 m; Volume = 1.982 m³; Panel orientation: Longitudinal axis
This section PASSES the design code check.

Limit States Design using CSA O86-14:

Criterion	Analysis Value	Design Value	Unit	Analysis/Design
Shear	Vf @d = 9.19	Vr = 27.95	kN	Vf/Vr = 0.33
Moment(+)	ME = 7.12	Mr = 58.05	kN-m	ME/Mr = 0.12
Moment(-)	ME = 8.86	Mr = 56.95	kN-m	ME/Mr = 0.16
Perm. Defl'n	1.9 < L/999	11.3 = L/360	mm	0.17
Live Defl'n	1.2 < L/999	11.3 = L/360	mm	0.11
Total Defl'n	5.1 = L/798	17.0 = L/240	mm	0.30
Vibration	Lmax = 4.070	Lv = 5.186	m	Lmax/Lv = 0.78

+ architectural details → **DA2**

+ structural details → **DS2**

+ installation guide → **GI2**

+ maintenance guide → **GE2**

+ product warranty → **N-X601**