

NORDIC

TECHNICAL GUIDE
NORDIC X-LAM

NS-GT6 

ENGLISH

VERSION
2026-02-01

Mass Timber Construction

NORDIC X-LAM TECHNICAL GUIDE

 NORDIC
X-LAM

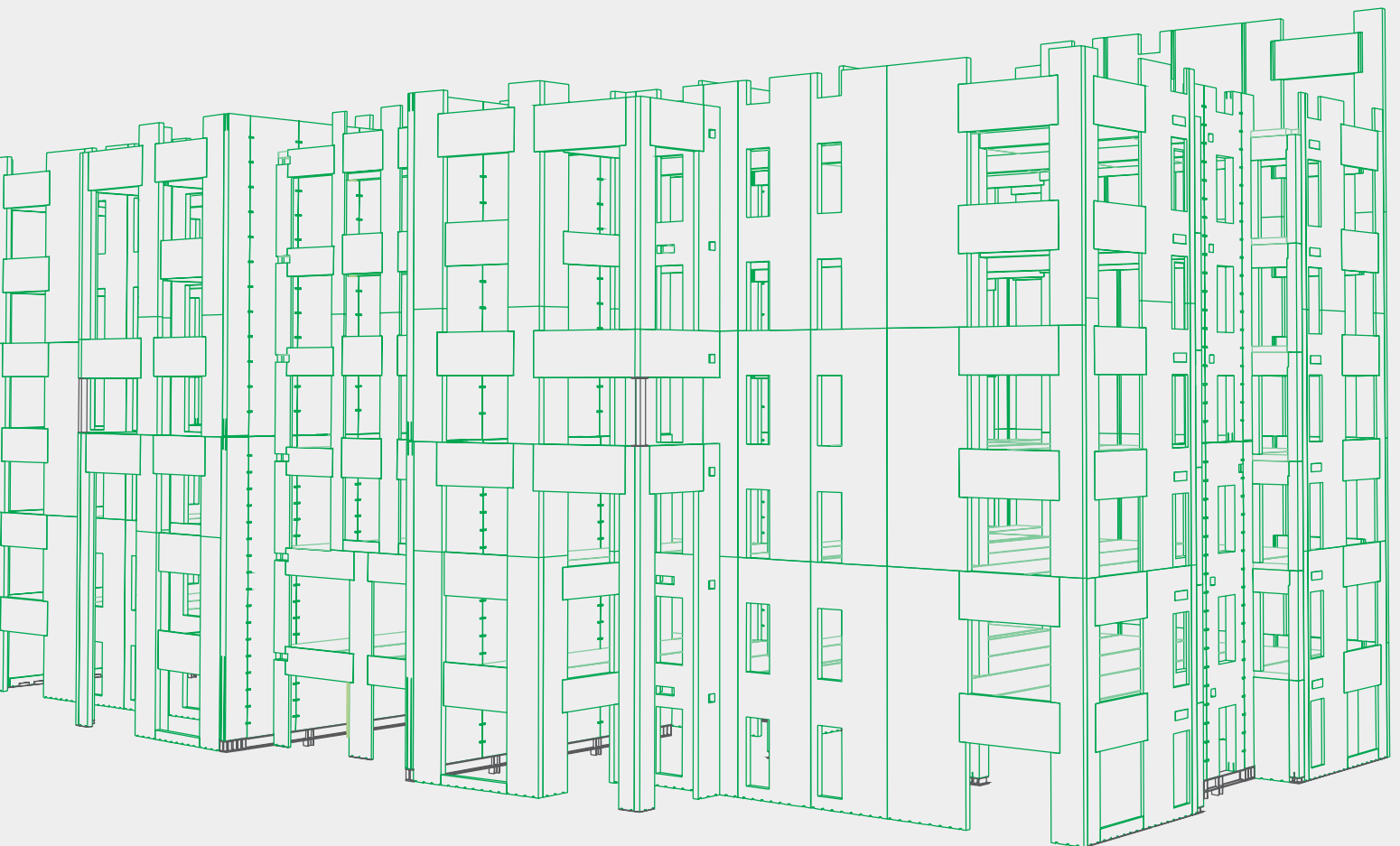

NORDIC
STRUCTURES

ABOUT NORDIC

NORDIC STRUCTURES

Nordic Structures is the leading innovator in mass timber construction. Its resource comes from responsibly managed lands within the regional boreal forest. Vertical integration, from forest to structure, bolstered by Nordic's experienced design and development team, ensures consistent quality and unparalleled level of service.

514-871-8526
1 866 817-3418

HEAD OFFICE

Nordic Structures

100-1100 Canadiens-de-Montréal Avenue
Montréal, Québec H3B 2S2

www.nordic.ca

GENERAL INFORMATION

info@nordic.ca

TECHNICAL SUPPORT

arch@nordic.ca

TABLE OF CONTENTS

NORDIC X-LAM

1

STRUCTURE

2

STRUCTURAL
DETAILS

3

ARCHITECTURAL
DETAILS

4

ADDITIONAL
INFORMATION

5

ENGINEERED WOOD PRODUCTS

Standard size products available from our distributors

NS-GT3



NORDIC I-JOISTS

Nordic I-joists are composed of sawn lumber flanges connected by a structural oriented strand board and bonded together with exterior-grade adhesives.

NI-20

2x3 S-P-F No. 2, 3/8 in. web
Depths
9-1/2 and 11-7/8 in.

NI-40x

2x3 1950f MSR, 3/8 in. web
Depths
9-1/2, 11-7/8 and 14 in.

NI-60

2x3 2100f MSR, 3/8 in. web
Depths
9-1/2, 11-7/8, 14 and 16 in.

NI-80

2x4 2100f MSR, 3/8 in. web
Depths
9-1/2, 11-7/8, 14 and 16 in.

NI-90

2x4 2400f MSR, 7/16 in. web
Depths
11-7/8, 14 and 16 in.

NI-80x

2x4 2100f MSR, 7/16 in. web
Depths
18, 20, 22 and 24 in.

RESIDENTIAL SERIES

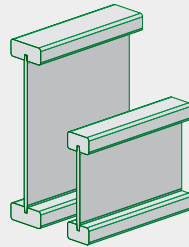

COMMERCIAL SERIES

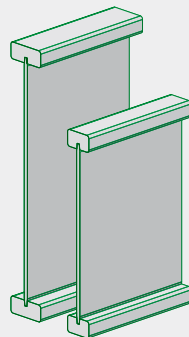

NS-GT4



NORDIC LAM GLUED-LAMINATED TIMBER

Nordic Lam glued-laminated timber of industrial appearance grade consists of small wood laminations bonded together in parallel using structural adhesives.

BEAMS AND HEADERS

Widths

1-3/4, 3-1/2, 5-1/2 and 7 in.

Depths

9-1/2, 11-7/8, 14, 16, 18, 20, 22 and 24 in.

Lengths*

Up to 48 ft

Stress grade

24F-1.9E

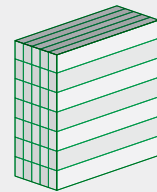

COLUMNS

Widths

3-1/2, 5-1/2 and 7 in.

Depths

3-1/2, 5-1/2 and 7 in.

Lengths*

Up to 48 ft

Stress grade

ES12



STUDS

Widths

1-1/2 and 1-3/4 in.

Depths

5-1/2 and 7-1/4 in.

Lengths*

Up to 48 ft

Stress grade

ES11



* Larger sizes available upon request

Products custom-manufactured
and machined for major projects

NS-GT5



NORDIC LAM+ GLUED-LAMINATED TIMBER

Nordic Lam+ glued-laminated timber of architectural appearance grade consists of small wood laminations bonded together in parallel using structural adhesives.

BEAMS AND COLUMNS

Widths*

38, 86, 137, 184, 216, 241, 292, 346, 394, 448, 502, 552 and 603 mm
(1-1/2, 3-3/8, 5-3/8, 7-1/4, 8-1/2, 9-1/2, 11-1/2, 13-5/8, 15-1/2,
17-5/8, 19-3/4, 21-3/4 and 23-3/4 in.)

Depths*

From 67 to 2435 mm
(2-5/8 to 95-7/8 in.)

Lengths*

Up to 24.4 m (80 ft)

Stress grade

24F-ES/NPG

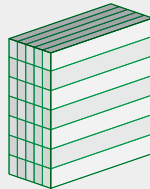

DECKING

Thicknesses*

38, 44, 54 and 89 mm
(1-1/2, 1-3/4, 2-1/8 and 3-1/2 in.)

Widths

203, 305 and 406 mm
(8, 12 and 16 in.)

Lengths

Up to 18.9 m (62 ft)

Stress grades

ES11, except 89 mm thickness in 20F-ES/CPG

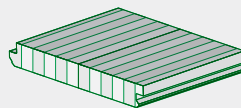

* Larger sizes available upon request

NS-GT6



NORDIC X-LAM CROSS-LAMINATED TIMBER

Nordic X-Lam cross-laminated timber is made of at least three orthogonal layers of graded sawn lumber that are laminated by gluing with structural adhesives.

SLABS AND PANELS

Layup combinations

89-3s, 105-3s,
143-5s, 175-5s,
197-7s, 213-7l, 245-7s, 245-7l
and 267-9l

Maximum sizes

2.565 × 19.5 m (101 in. × 64 ft)

Stress grade

E1 (L 1950Fb and T No. 3/Stud)

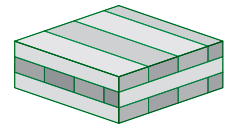

NORDIC

TECHNICAL GUIDE
NORDIC X-LAM

NS-GT6 

ENGLISH
VERSION
2026-02-01

NORDIC X-LAM

1

CLT



NORDIC X-LAM
CROSS-LAMINATED TIMBER

Nordic X-Lam cross-laminated timber is made of at least three orthogonal layers of graded sawn lumber that are laminated by gluing with structural adhesives.

SLABS AND PANELS

Layup combinations

89-3s, 105-3s,
143-5s, 175-5s,
197-7s, 213-7l, 245-7s, 245-7l
and 267-9l

Maximum sizes

2.565 × 19.5 m (101 in. × 64 ft)

Stress grade

E1 (L 1950Fb and T No. 3/Stud)

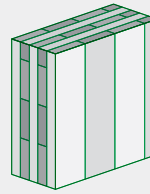
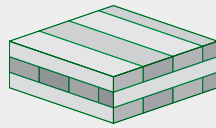

NORDIC X-LAM LAYUP COMBINATIONS

3 LAYERS

89-3s

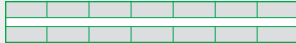

105-3s

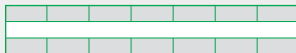

5 LAYERS

143-5s

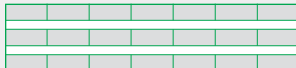

175-5s

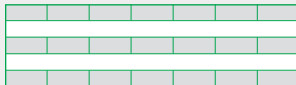

7 LAYERS

197-7s

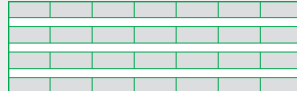

213-7l

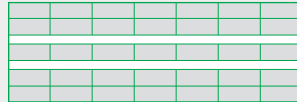

245-7s

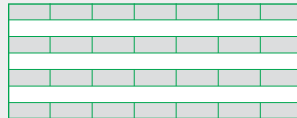

245-7l

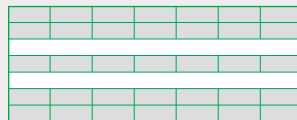

9 LAYERS

267-9l

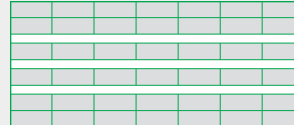

Nordic X-Lam – Specification Guide

Specifications

Cross-laminated timber (CLT) products shall be used in dry service conditions, such as in most covered structures, where the average equilibrium moisture content of solid wood over a year is 15% or less and does not exceed 19%. CLT products are intended to resist the effects of moisture on structural performance as may occur due to construction delays or other conditions of similar severity.

Master format 06 17 19

REFERENCE STANDARD

- .1 ANSI/APA PRG 320-[2018], Standard for Performance-Rated Cross-Laminated Timber.

ACTION AND INFORMATION SUBMITTALS

- .1 Submit the product report published by a certification agency accredited by the Standards Council of Canada at completion of fabrication.

MATERIALS

- .1 Laminating stock: Spruce-Pine-Fir, [FSC certified]
- .2 Sealer: Penetrating type, clear sealer (Sansin KP-12UVW) applied only to exposed (architectural-grade) surfaces
- .3 Preservative: [Specify as required]
- .4 Fire retardant: [Specify as required]

FABRICATION

- .1 Stress grade: E1
- .2 Service grade: Interior
- .3 Appearance grade:
 - SPEC NOTE: Typically, only the exposed (visible) surfaces are of architectural appearance grade.*
 - Faces: [industrial (U.N.O.)] [one industrial face – one architectural face] [architectural]
 - Edges: industrial
 - Note: Laminations are not edge-glued; Panel edges are not meant to be showcased.
- .4 Fire resistance: [Specify as required]

ERECTION

- .1 Erect cross-laminated timber members in accordance with erection drawings issued for construction.

For the detailed specification guide: <https://www.nordic.ca/en/documentation/technical-documents>

Nordic X-Lam – Appearance Grades

The following examples of CLT appearance grades are for reference only. These requirements are based on the appearance at the time of manufacturing. The actual CLT product appearance requirements are recommended to be agreed upon between the buyer and the seller.



Industrial Appearance

An appearance grade normally suitable for use in concealed applications where appearance is not of primary concern. Specific characteristics of this grade are as follows:

- Voids appearing on the edges of laminations need not be filled.
- Loose knots and knot holes appearing on the face layers exposed to view are not filled.
- Members are surfaced on face layers only and the appearance requirements apply only to these layers.
- Occasional misses, low laminations or wane (limited to the lumber grade) are permitted on the surface layers and are not limited in length.



Architectural Appearance

An appearance grade normally suitable for applications where appearance is an important but not overriding consideration. Specific characteristics of this grade are as follows:

- In exposed surfaces, all knot holes and voids measuring over 19 mm are filled with a wood-tone filler or clear wood inserts selected for similarity with the grain and color of the adjacent wood.
- The face layers exposed to view are free of loose knots and open knot holes are filled.
- Knot holes do not exceed 19 mm when measured in the direction of the lamination length with the exception that a void may be longer than 19 mm if its area is not greater than 323 mm².
- Voids greater than 1.6 mm wide created by edge joints appearing on the face layers exposed to view are filled.
- Exposed surfaces are surfaced smooth with no misses permitted.

Nordic X-Lam – Certifications

Product Certifications

Nordic X-Lam cross-laminated timber (CLT) products, certified by APA – The Engineered Wood Association (apawood.org), are manufactured in accordance with the applicable standards and associated specifications indicated below:

- ANSI/APA PRG 320, Standard for Performance-Rated Cross-Laminated Timber
- CCMC Listing 13654-L
- APA Product Report PR-L306C

APA is a not-for-profit trade association and is accredited by the Standards Council of Canada (SCC) as a Product Certification Body under ISO Guide 65. APA is also an accredited testing organization recognized by SCC under ISO/IEC 17025.

The ANSI/APA PRG 320 standard is recognized in the National Building Code (NBC) and is required for using the design provisions specified in CSA O86, Engineering design in wood.

Green Certifications

Wood – efficient and ecological

Overview of environmental certifications:

- Green Verification Report APA GR-L306
- Low Formaldehyde Emissions Products APA PR-E740
- Environmental Product Declaration (EPD), Nordic X-Lam
- Health Product Declaration (HPD), Nordic X-Lam
- Declare (ILFI), Nordic X-Lam
- USDA Certified Biobased Product, Product 100%
- Cradle to Cradle Certified, Nordic X-Lam
- FSC-certified products available

Note: For independently verified LEED (Leadership in Energy and Environmental Design) points, refer to APA GR-L306.

See nordic.ca for details.

Nordic X-Lam – Transparency Brief

The Nordic X-Lam business-to-business environmental product declaration (EPD) is based on a cradle-to-gate life cycle analysis (LCA). The delivery of the product to the customer, its use and eventual end-of-life processing are excluded from the EPD.

Forest Operations

The assessment of the life cycle impacts of Nordic wood product begins with its origin in managed forests and the energy use and emissions caused by its extraction. Forest management and reforestation that occurs after extraction are also included.

Nordic is committed to sustainable forestry as defined in the Forest Stewardship Council (FSC) forest management certification. Nordic's wood fiber sources fall into the following category:

- Certified sources of wood fiber come from FSC certified forests

CLT Production

The cross-laminated timber (CLT) production phase begins with the transportation of logs to the finished product. These processes consume fossil fuel (65.7%), electricity drawn from regional grids (22.5%), internally generated biomass (9.4%) and nuclear (2.4%).

Environmental Impacts

Atmosphere

Global warming potential	121.89 kg CO ₂ eq.
Ozone depletion potential	1.79E-06 kg CFC-11 eq.
Photochemical ozone creation potential	35.53 kg O ₃ eq.

Water

Acidification potential	1.19 kg SO ₂ eq.
Eutrophication potential	0.11 kg N eq.

Earth

Depletion of abiotic resources (elements)	38.84 kg
Depletion of abiotic resources (fossil fuels)	1831.88 MJ

Material Content

Component – for 1 m ³ of Nordic X-Lam	Mass (kg)	Mass (%)
Wood (on oven dry basis); renewable	406 kg	98.9 %
Resins (polyurethane and isocyanate)	4.46 kg	1.1 %
Total	410.46 kg	100 %

Carbon Balance

Impact Category – for 1 m ³ of Nordic X-Lam	Carbon (kg of CO ₂ eq.)
Forest carbon uptake	-741.36 kg of CO ₂ eq.
Life cycle greenhouse gas emissions	121.89 kg of CO ₂ eq.
Unaccounted biogenic carbon emissions	28.50 kg of CO ₂ eq.
Net global warming potential	-590.97 kg of CO ₂ eq.

See nordic.ca for details.

NORDIC

TECHNICAL GUIDE
NORDIC X-LAM

NS-GT6 

ENGLISH
VERSION
2026-02-01

STRUCTURE

2



Nordic X-Lam – Design Properties

Characteristics

Nordic X-Lam cross-laminated timber (CLT) is certified according to E1 CLT stress grade, using 1950 F_b-1.7E Spruce-Pine-Fir (S-P-F) MSR lumber in longitudinal layers and No. 3/Stud S-P-F lumber in the transverse layers. Nordic X-Lam products are certified by APA (Product Report PR-L306C) per the ANSI/APA PRG 320 Standard and shall be used in dry service conditions.

Material Design Properties

CLT stress grade	E1	
	Layers	
Orientation	Longitudinal	Transversal
Species combination	S-P-F	S-P-F
Stress class	1950 F _b -1.7E MSR	No. 3/Stud
Bending at extreme fibre, f_b (MPa)	28.2	7.0
Longitudinal shear, f_v (MPa)	1.5	1.5
Rolling shear, f_s (MPa)	0.5	0.5
Compression parallel to grain, f_c (MPa)	19.3	9.0
Compression perpendicular to grain, f_{cp} (MPa)	5.3	5.3
Tension parallel to grain, f_t (MPa)	15.4	3.2
Modulus of elasticity, E (MPa)	11 700	9 000
Shear modulus, G (MPa)	731	563
Rolling shear modulus, G_s (MPa)	73.1	56.3

Note:

1. Appearance grades as defined in ANSI/APA PRG 320 do not affect the structural performance of CLT panels.

Panel Layups

Layup ^(a)	Thickness and orientation of layers ^(b)	Number of layers	Thickness		Weight		
			(mm)	(in.)	(kg/m ²)	(kN/m ²)	(psf)
89-3s	35L - 19T - 35L	3	89	3-1/2	45.9	0.45	9.40
105-3s	35L - 35T - 35L	3	105	4-1/8	54.1	0.53	11.1
143-5s	35L - 19T - 35L - 19T - 35L	5	143	5-5/8	73.7	0.72	15.1
175-5s	35L - 35T - 35L - 35T - 35L	5	175	6-7/8	90.1	0.88	18.5
197-7s	35L - 19T - 35L - 19T - 35L - 19T - 35L	7	197	7-3/4	102	1.00	20.8
213-7l	35L - 35L - 19T - 35L - 19T - 35L - 35L	7	213	8-3/8	110	1.08	22.5
245-7s	35L - 35T - 35L - 35T - 35L - 35T - 35L	7	245	9-5/8	126	1.24	25.9
245-7l	35L - 35L - 35T - 35L - 35T - 35L - 35L	7	245	9-5/8	126	1.24	25.9
267-9l	35L - 35L - 19T - 35L - 19T - 35L - 19T - 35L - 35L	9	267	10-1/2	138	1.35	28.2

a) The layup designation refers to the panel thickness (in mm), the number of layers, and the layer orientations ("s" for standard perpendicular layers, and "l" for doubled outermost parallel layers).

b) L = longitudinal, T = transversal, 35 = 35 mm, 19 = 19.1 mm

Floor/Roof Slabs – Design Properties

Floor/Roof Slabs – Design Properties

CLT stress grade	E1 (L = 1950 F _b -1.7E S-P-F MSR and T = No. 3/Stud S-P-F)								
Layup	89-3s	105-3s	143-5s	175-5s	197-7s	213-7l	245-7s	245-7l	267-9l
Bending in the major strength direction									
Flatwise bending moment resistance, $M_{r,f,0}$ (kN-m/m) ^(a)	28	38	65	88	116	158	155	200	239
Flatwise shear resistance, $V_{r,f,0}$ (kN/m) ^(b)	27	32	43	53	59	64	74	74	80
Effective flatwise bending stiffness, $(EI)_{\text{eff},f,0}$ (10^9 N-mm ² /m)	683	1 088	2 531	4 166	6 194	9 117	10 306	13 279	17 327
Effective shear stiffness in flatwise bending, $(GA)_{\text{eff},f,0}$ (10^6 N/m)	7.6	7.3	15	15	23	25	22	22	32
Bending in the minor strength direction									
Flatwise bending moment resistance, $M_{r,f,90}$ (kN-m/m) ^(a)	0.38	1.3	5.0	11	11	5.0	26	11	11
Flatwise shear resistance, $V_{r,f,90}$ (kN/m) ^(b)	5.7	11	22	32	38	22	53	32	38
Effective flatwise bending stiffness, $(EI)_{\text{eff},f,90}$ (10^9 N-mm ² /m)	5.2	32	263	837	1 045	263	3 220	837	1 045
Effective shear stiffness in flatwise bending, $(GA)_{\text{eff},f,90}$ (10^6 N/m)	5.7	9.1	11	18	17	14	27	20	19

a) The factored flatwise bending moment resistance values, $M_{r,f}$, include the resistance factor, ϕ , and the adjustment factor K_{tb} as defined in CSA O86:19.

b) The factored flatwise shear resistance values, $V_{r,f}$, include the resistance factor, ϕ .

Notes:

1. The tabulated design values are for dry service conditions and standard-term duration of load.
2. The compressive resistance perpendicular to grain values shall be based on S-P-F No. 3/Stud lumber ($f_{cp} = 5.3$ MPa).
3. The specific gravity for dowel-type fastener design, G , is 0.42.
4. The density for member weight is 515 kg/m^3 (5.1 kN/m^3) for a moisture content of 12%.
5. Design of CLT members shall be in accordance with CSA O86:19.

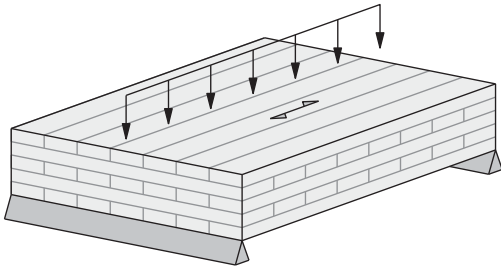

Bending in the major strength direction

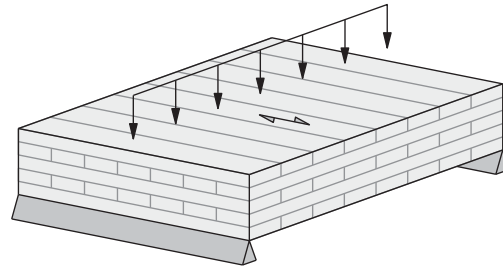

Bending in the minor strength direction

Floor Slabs – Sizing

Live load = 1.9 kPa – Simple Span

Layup selection

Dead load ^(a) (kPa)	L (m) ^(b, c)																		
	2.50	2.75	3.00	3.25	3.50	3.75	4.00	4.25	4.50	4.75	5.00	5.25	5.50	5.75	6.00	6.25	6.50	6.75	7.00
1.0																			
1.5					89-3s	89-3s	105-3s												
2.0			89-3s	89-3s	105-3s	105-3s					143-5s								
2.5		89-3s	89-3s	105-3s	105-3s			143-5s	143-5s	143-5s		175-5s	175-5s						
3.0	89-3s	89-3s	89-3s	105-3s	105-3s			143-5s	143-5s	143-5s		175-5s	175-5s						
3.5				105-3s	143-5s	143-5s						175-5s	175-5s						245-7s
4.0					143-5s	143-5s						197-7s	197-7s						245-7s
4.5			105-3s	143-5s	143-5s	143-5s		143-5s	175-5s	175-5s		197-7s	197-7s						245-7s
5.0		105-3s	105-3s	143-5s	143-5s	143-5s		143-5s	175-5s	175-5s	197-7s	197-7s	197-7s	197-7s	197-7s	197-7s	197-7s	197-7s	197-7s

Live load = 1.9 kPa – Double Span

Layup selection

Dead load ^(a) (kPa)	L (m) ^(b, d)																		
	2.50	2.75	3.00	3.25	3.50	3.75	4.00	4.25	4.50	4.75	5.00	5.25	5.50	5.75	6.00	6.25	6.50	6.75	7.00
1.0																			
1.5					89-3s	89-3s													
2.0			89-3s	89-3s	89-3s	89-3s													
2.5		89-3s	89-3s	89-3s	89-3s	89-3s		105-3s	105-3s	143-5s	143-5s	143-5s							
3.0	89-3s	89-3s	89-3s	89-3s	89-3s	89-3s		105-3s	105-3s	143-5s	143-5s	143-5s							197-7s
3.5				89-3s	89-3s	89-3s			143-5s	143-5s	143-5s	143-5s							
4.0				89-3s	89-3s	89-3s		105-3s	143-5s	143-5s	143-5s	143-5s							
4.5			89-3s	89-3s	89-3s	105-3s		143-5s	143-5s	143-5s	143-5s	143-5s							
5.0		89-3s	89-3s	89-3s	89-3s	105-3s		143-5s	143-5s	143-5s	143-5s	143-5s	175-5s						197-7s

- a) Specified dead load. The panel self weight is considered in the calculation and shall not be included in the specified dead load.
- b) Span is measured centre to centre of supports.
- c) The maximum spans for vibration control, l_v , are increased by 10% as recommended by Nordic Structures.
- d) The maximum spans for vibration control, l_v , are increased by 20% for non-structural elements that are considered to provide enhanced vibration effect.

Notes:

1. For preliminary design use only. Final design shall include a complete analysis including the verification of the factored bearing resistance.
2. Tables are based on uniform loads and dry service conditions, for bending in the major strength direction of the panel.
3. The ultimate limit states take into account the factored bending moment and shear resistances. The serviceability limit states include the consideration for floor vibration, a live load deflection limit of $L/360$ and a total load deflection limit of $L/180$.
4. Fire-resistance rating takes into account the bending moment and the shear resistances of the effective cross-section.
5. Fire-resistance rating:

30 min	60 min	90 min	120 min
--------	--------	--------	---------

Live load = 2.4 kPa – Simple Span

Layup selection

Dead load ^(a) (kPa)	L (m) ^(b, c)																		
	2.50	2.75	3.00	3.25	3.50	3.75	4.00	4.25	4.50	4.75	5.00	5.25	5.50	5.75	6.00	6.25	6.50	6.75	7.00
1.0																			
1.5																			
2.0																			
2.5																			
3.0																			
3.5																			
4.0																			
4.5																			
5.0																			

Live load = 2.4 kPa – Double Span

Layup selection

Dead load ^(a) (kPa)	L (m) ^(b, d)																		
	2.50	2.75	3.00	3.25	3.50	3.75	4.00	4.25	4.50	4.75	5.00	5.25	5.50	5.75	6.00	6.25	6.50	6.75	7.00
1.0																			
1.5																			
2.0																			
2.5																			
3.0																			
3.5																			
4.0																			
4.5																			
5.0																			

- a) Specified dead load. The panel self weight is considered in the calculation and shall not be included in the specified dead load.
- b) Span is measured centre to centre of supports.
- c) The maximum spans for vibration control, l_v , are increased by 10% as recommended by Nordic Structures.
- d) The maximum spans for vibration control, l_v , are increased by 20% for non-structural elements that are considered to provide enhanced vibration effect.

Notes:

1. For preliminary design use only. Final design shall include a complete analysis including the verification of the factored bearing resistance and of a concentrated live load as defined in Article 4.1.5.9. of the 2015 NBC (if applicable).
2. Tables are based on uniform loads and dry service conditions, for bending in the major strength direction of the panel.
3. The ultimate limit states take into account the factored bending moment and shear resistances. The serviceability limit states include the consideration for floor vibration, a live load deflection limit of $L/360$ and a total load deflection limit of $L/180$.
4. Fire-resistance rating takes into account the bending moment and the shear resistances of the effective cross-section.
5. Fire-resistance rating:

30 min	60 min	90 min	120 min
--------	--------	--------	---------

Live load = 4.8 kPa – Simple Span

Layup selection

Dead load ^(a) (kPa)	L (m) ^(b, c)																		
	2.50	2.75	3.00	3.25	3.50	3.75	4.00	4.25	4.50	4.75	5.00	5.25	5.50	5.75	6.00	6.25	6.50	6.75	7.00
1.0		89-3s	89-3s	105-3s	105-3s	143-5s	143-5s	143-5s											
1.5		89-3s	89-3s	105-3s	105-3s	143-5s	143-5s	143-5s											
2.0	89-3s	89-3s	105-3s	105-3s	143-5s	143-5s	143-5s	143-5s											
2.5	89-3s	89-3s	105-3s	105-3s	143-5s	143-5s	143-5s	143-5s											
3.0			105-3s	105-3s	143-5s	143-5s	143-5s	143-5s											
3.5					143-5s	143-5s	143-5s	143-5s											
4.0					143-5s	143-5s	143-5s	143-5s											
4.5	89-3s	105-3s	143-5s	143-5s	143-5s	143-5s	143-5s	143-5s											
5.0			143-5s	143-5s	143-5s	143-5s	143-5s	143-5s											

Live load = 4.8 kPa – Double Span

Layup selection

Dead load ^(a) (kPa)	L (m) ^(b, d)																		
	2.50	2.75	3.00	3.25	3.50	3.75	4.00	4.25	4.50	4.75	5.00	5.25	5.50	5.75	6.00	6.25	6.50	6.75	7.00
1.0		89-3s					143-5s	143-5s											
1.5		89-3s					143-5s	143-5s											
2.0	89-3s						143-5s	143-5s											
2.5	89-3s						143-5s	143-5s											
3.0			89-3s		105-3s	105-3s	143-5s	143-5s											
3.5		89-3s			105-3s	105-3s	143-5s	143-5s											
4.0	89-3s						143-5s	143-5s											
4.5	89-3s			105-3s			143-5s	143-5s											
5.0				105-3s			143-5s	143-5s											

- a) Specified dead load. The panel self weight is considered in the calculation and shall not be included in the specified dead load.
- b) Span is measured centre to centre of supports.
- c) The maximum spans for vibration control, l_v , are increased by 10% as recommended by Nordic Structures.
- d) The maximum spans for vibration control, l_v , are increased by 20% for non-structural elements that are considered to provide enhanced vibration effect.

Notes:

1. For preliminary design use only. Final design shall include a complete analysis including the verification of the factored bearing resistance and of a concentrated live load as defined in Article 4.1.5.9. of the 2015 NBC (if applicable).
2. Tables are based on uniform loads and dry service conditions, for bending in the major strength direction of the panel.
3. The ultimate limit states take into account the factored bending moment and shear resistances. The serviceability limit states include the consideration for floor vibration, a live load deflection limit of $L/360$ and a total load deflection limit of $L/180$.
4. Fire-resistance rating takes into account the bending moment and the shear resistances of the effective cross-section.
5. Fire-resistance rating:

30 min	60 min	90 min	120 min
--------	--------	--------	---------

Floor Slabs – Selection Tables

Ultimate Limit States – Factored Bending Moment and Shear Resistances

Maximum factored uniform load (kPa)

L ^(a) (m)	Layout								
	89-3s	105-3s	143-5s	175-5s	197-7s	213-7l	245-7s	245-7l	267-9l
3.0									
3.2	14.13								
3.4	13.26								
3.6	12.49	14.92							
3.8	11.81	14.10							
4.0	11.20	13.36							
4.2	10.65	12.70							
4.4	10.15	12.10							
4.6	9.69	11.55							
4.8	9.28	11.05							
5.0	8.89	10.60	14.42						
5.2	8.28	10.17	13.84						
5.4	7.68	9.79	13.31						
5.6	7.14	9.43	12.81						
5.8	6.66	9.04	12.35						
6.0	6.22	8.44	11.92	14.83					
6.2	5.83	7.91	11.52	14.32					
6.4	5.47	7.42	11.15	13.86					
6.6	5.14	6.98	10.80	13.42					
6.8	4.84	6.57	10.47	13.01	14.56				
7.0	4.57	6.20	10.16	12.62	14.12				
7.2	4.32	5.86	9.87	12.25	13.71	14.93			
7.4	4.09	5.55	9.50	11.91	13.33	14.51			
7.6	3.88	5.26	9.00	11.58	12.96	14.11			
7.8	3.68	5.00	8.55	11.28	12.61	13.73			
8.0	3.50	4.75	8.13	10.98	12.28	13.37			
8.2		4.52	7.73	10.47	11.97	13.03			
8.4		4.31	7.37	9.98	11.68	12.71	14.79	14.79	
8.6		4.11	7.03	9.52	11.40	12.40	14.42	14.42	
8.8		3.93	6.71	9.09	11.13	12.11	14.08	14.08	
9.0		3.75	6.42	8.69	10.87	11.83	13.75	13.75	14.93
9.2		3.59	6.14	8.32	10.63	11.56	13.44	13.44	14.59
9.4			5.89	7.97	10.39	11.30	13.14	13.14	14.27
9.6			5.64	7.64	10.07	11.06	12.86	12.86	13.96
9.8			5.41	7.33	9.66	10.83	12.59	12.59	13.66

Ultimate limit states

- $M_r \geq M_f$
- $V_r \geq V_f$

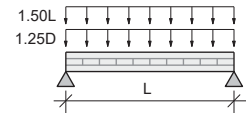
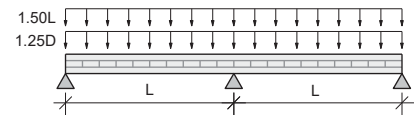

a) Span is measured centre to centre of supports.

Notes:

- For preliminary design use only. Final design shall include a complete analysis including the verification of the factored bending moment, shear, and bearing resistances and a consideration for live load and total load deflections. If applicable, the final design shall include a consideration for floor vibration, the verification of a concentrated live load as defined in Article 4.1.5.9. of the 2015 NBC, and fire-resistance requirements.
- The tabulated values are based on dry service conditions, standard-term duration of load, and the most restrictive of simple span or double span, for bending in the major strength direction of the panel.
- The above values apply to slabs with a specified dead load less or equal to the specified live load. If the specified dead load is greater than the specified live load, multiply the maximum factored uniform load by the corresponding adjustment factor:

Adjustment factor based on specified dead load / specified live load ratio (D/L)

D/L	1.00	1.25	1.50	1.75	2.00	2.25	2.50	2.75	3.00
Factor	1.000	0.952	0.912	0.878	0.849	0.824	0.801	0.780	0.761

Serviceability Limit States – L/180, Simple Span

Maximum specified uniform total load (kPa)

L ^(a) (m)	Layup								
	89-3s	105-3s	143-5s	175-5s	197-7s	213-7l	245-7s	245-7l	267-9l
3.0	6.56	9.88							
3.2	5.46	8.28							
3.4	4.59	7.00							
3.6	3.90	5.97							
3.8		5.13	11.79						
4.0		4.43	10.21						
4.2		3.86	8.89						
4.4			7.79						
4.6			6.87	10.81					
4.8			6.08	9.60					
5.0			5.40	8.56					
5.2			4.83	7.67	11.43				
5.4			4.33	6.89	10.27				
5.6			3.89	6.21	9.26				
5.8			3.52	5.62	8.38				
6.0				5.10	7.61	10.94			
6.2				4.64	6.92	9.97	11.01		
6.4				4.24	6.32	9.11	10.07		
6.6				3.88	5.78	8.34	9.24	11.59	
6.8				3.56	5.30	7.66	8.49	10.67	
7.0					4.87	7.05	7.82	9.84	
7.2					4.49	6.50	7.22	9.10	12.00
7.4					4.15	6.01	6.68	8.42	11.10
7.6					3.84	5.56	6.19	7.81	10.30
7.8					3.56	5.16	5.75	7.26	9.56
8.0						4.80	5.34	6.76	8.90
8.2						4.47	4.98	6.30	8.29
8.4						4.16	4.64	5.88	7.74
8.6						3.89	4.34	5.50	7.23
8.8						3.64	4.06	5.15	6.77
9.0							3.80	4.83	6.35
9.2							3.57	4.53	5.96
9.4								4.26	5.60
9.6								4.01	5.27
9.8								3.78	4.96

Serviceability limit states
 • $\Delta_{ST} + \Delta_{LT} K_{creep} \leq L/180$

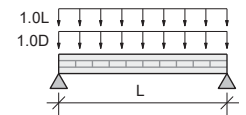

a) Span is measured centre to centre of supports.

Notes:

- For preliminary design use only. Final design shall include a complete analysis including the verification of the factored bending moment, shear, and bearing resistances and a consideration for live load and total load deflections. If applicable, the final design shall include a consideration for floor vibration, the verification of a concentrated live load as defined in Article 4.1.5.9. of the 2015 NBC, and fire-resistance requirements.
- The tabulated values are based on dry service conditions, for bending in the major strength direction of the panel.
- The above values apply to slabs with a specified dead load less or equal to the specified live load. If the specified dead load is greater than the specified live load, multiply the maximum specified uniform total load by the corresponding adjustment factor:

Adjustment factor based on specified dead load / specified live load ratio (D/L)

D/L	1.00	1.25	1.50	1.75	2.00	2.25	2.50	2.75	3.00
Factor	1.000	0.964	0.938	0.917	0.900	0.886	0.875	0.865	0.857

Serviceability Limit States – L/180, Double Span

Maximum specified uniform total load (kPa)

L ^(a) (m)	Layup								
	89-3s	105-3s	143-5s	175-5s	197-7s	213-7l	245-7s	245-7l	267-9l
3.0	11.90								
3.2	9.99								
3.4	8.47								
3.6	7.23	10.71							
3.8	6.22	9.28							
4.0	5.39	8.08							
4.2	4.69	7.08							
4.4	4.11	6.23							
4.6	3.62	5.51							
4.8		4.90	11.24						
5.0		4.37	10.03						
5.2		3.91	9.00						
5.4		3.52	8.09						
5.6			7.31	11.36					
5.8			6.62	10.32					
6.0			6.01	9.41					
6.2			5.47	8.59					
6.4			5.00	7.87	11.74				
6.6			4.58	7.22	10.78				
6.8			4.20	6.65	9.91				
7.0			3.87	6.13	9.14				
7.2			3.56	5.66	8.44				
7.4				5.24	7.81	11.17			
7.6				4.86	7.24	10.37	11.38		
7.8				4.51	6.73	9.64	10.60		
8.0				4.20	6.26	8.98	9.88		
8.2				3.91	5.83	8.38	9.23	11.51	
8.4				3.65	5.44	7.83	8.63	10.78	
8.6					5.08	7.32	8.08	10.11	
8.8					4.76	6.86	7.58	9.49	
9.0					4.46	6.44	7.12	8.92	11.79
9.2					4.19	6.04	6.69	8.40	11.09
9.4					3.93	5.68	6.30	7.91	10.45
9.6					3.70	5.35	5.93	7.46	9.85
9.8						5.04	5.60	7.04	9.29

Serviceability limit states

$$\bullet \Delta_{ST} + \Delta_{LT} K_{creep} \leq L/180$$

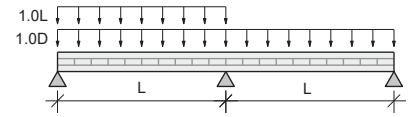

a) Span is measured centre to centre of supports.

Notes:

- For preliminary design use only. Final design shall include a complete analysis including the verification of the factored bending moment, shear, and bearing resistances and a consideration for live load and total load deflections. If applicable, the final design shall include a consideration for floor vibration, the verification of a concentrated live load as defined in Article 4.1.5.9. of the 2015 NBC, and fire-resistance requirements.
- The tabulated values are based on dry service conditions, for bending in the major strength direction of the panel.
- The above values apply to slabs with a specified dead load less or equal to the specified live load. If the specified dead load is greater than the specified live load, multiply the maximum specified uniform total load by the corresponding adjustment factor:

Adjustment factor based on specified dead load / specified live load ratio (D/L)

D/L	1.00	1.25	1.50	1.75	2.00	2.25	2.50	2.75	3.00
Factor	1.000	0.964	0.938	0.917	0.900	0.886	0.875	0.865	0.857

Serviceability Limit States – L/360, Simple Span

Maximum specified uniform live load (kPa)

L ^(a) (m)	Layup								
	89-3s	105-3s	143-5s	175-5s	197-7s	213-7l	245-7s	245-7l	267-9l
3.0	4.92	7.42							
3.2	4.10	6.21							
3.4	3.45	5.26							
3.6	2.93	4.48							
3.8	2.51	3.85							
4.0	2.16	3.33	7.66						
4.2		2.90	6.67						
4.4		2.54	5.85						
4.6		2.23	5.15	8.11					
4.8		1.98	4.56	7.20					
5.0			4.06	6.42					
5.2			3.62	5.75					
5.4			3.25	5.17	7.71				
5.6			2.92	4.66	6.95				
5.8			2.64	4.22	6.29				
6.0			2.39	3.83	5.71	8.21			
6.2			2.17	3.49	5.20	7.48	8.26		
6.4			1.98	3.18	4.74	6.84	7.56		
6.6				2.91	4.34	6.26	6.93		
6.8				2.67	3.98	5.75	6.37	8.01	
7.0				2.46	3.66	5.29	5.87	7.39	
7.2				2.26	3.37	4.88	5.42	6.83	
7.4				2.09	3.11	4.51	5.01	6.32	8.33
7.6				1.94	2.88	4.18	4.65	5.86	7.73
7.8					2.67	3.88	4.31	5.45	7.18
8.0					2.48	3.60	4.01	5.07	6.68
8.2					2.31	3.35	3.74	4.73	6.22
8.4					2.15	3.13	3.49	4.42	5.81
8.6					2.01	2.92	3.26	4.13	5.43
8.8						2.73	3.05	3.87	5.08
9.0						2.56	2.86	3.63	4.76
9.2						2.40	2.68	3.40	4.47
9.4						2.25	2.52	3.20	4.20
9.6						2.12	2.37	3.01	3.95
9.8						1.99	2.23	2.84	3.73

Serviceability limit states
• $\Delta_L \leq L/360$

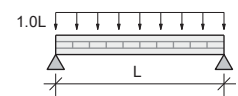

a) Span is measured centre to centre of supports.

Notes:

- For preliminary design use only. Final design shall include a complete analysis including the verification of the factored bending moment, shear, and bearing resistances and a consideration for live load and total load deflections. If applicable, the final design shall include a consideration for floor vibration, the verification of a concentrated live load as defined in Article 4.1.5.9. of the 2015 NBC, and fire-resistance requirements.
- The tabulated values are based on dry service conditions, for bending in the major strength direction of the panel.

Serviceability Limit States – L/360, Double Span

Maximum specified uniform live load (kPa)

L ^(a) (m)	Layup								
	89-3s	105-3s	143-5s	175-5s	197-7s	213-7l	245-7s	245-7l	267-9l
3.0	6.76								
3.2	5.65	8.41							
3.4	4.77	7.15							
3.6	4.06	6.12							
3.8	3.48	5.28							
4.0	3.01	4.58							
4.2	2.62	4.00							
4.4	2.29	3.51	8.06						
4.6	2.01	3.10	7.12						
4.8		2.74	6.32						
5.0		2.44	5.63						
5.2		2.18	5.04	7.89					
5.4		1.96	4.52	7.11					
5.6			4.08	6.43					
5.8			3.69	5.83					
6.0			3.34	5.30	7.90				
6.2			3.04	4.83	7.20				
6.4			2.78	4.42	6.58				
6.6			2.54	4.05	6.03				
6.8			2.33	3.72	5.54	7.95			
7.0			2.14	3.42	5.10	7.33	8.07		
7.2			1.97	3.16	4.70	6.77	7.46		
7.4				2.92	4.35	6.26	6.91		
7.6				2.70	4.03	5.81	6.42	8.04	
7.8				2.51	3.74	5.39	5.97	7.48	
8.0				2.33	3.47	5.02	5.56	6.98	
8.2				2.17	3.23	4.67	5.18	6.51	
8.4				2.03	3.02	4.36	4.84	6.09	8.03
8.6					2.82	4.08	4.53	5.70	7.52
8.8					2.63	3.82	4.24	5.35	7.05
9.0					2.47	3.58	3.98	5.02	6.61
9.2					2.31	3.36	3.74	4.72	6.21
9.4					2.17	3.15	3.51	4.44	5.84
9.6					2.04	2.97	3.31	4.18	5.50
9.8					1.92	2.80	3.12	3.95	5.19

Serviceability limit states
• $\Delta_L \leq L/360$

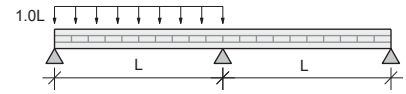

a) Span is measured centre to centre of supports.

Notes:

- For preliminary design use only. Final design shall include a complete analysis including the verification of the factored bending moment, shear, and bearing resistances and a consideration for live load and total load deflections. If applicable, the final design shall include a consideration for floor vibration, the verification of a concentrated live load as defined in Article 4.1.5.9. of the 2015 NBC, and fire-resistance requirements.
- The tabulated values are based on dry service conditions, for bending in the major strength direction of the panel.

Serviceability Limit States – Vibration, Simple Span

Maximum span, l_v (m)

Span	Layup								
	89-3s	105-3s	143-5s	175-5s	197-7s	213-7l	245-7s	245-7l	267-9l
Simple	3.76	4.22	5.20	5.86	6.48	7.18	7.32	7.88	8.42

Notes:

1. The maximum spans for vibration control, l_v , are increased by 10% as recommended by Nordic Structures.
2. The tabulated values apply to simply supported floor slabs.

Serviceability Limit States – Vibration, Double Span

Maximum span, l_v (m)

Span	Layup								
	89-3s	105-3s	143-5s	175-5s	197-7s	213-7l	245-7s	245-7l	267-9l
Double	4.10	4.61	5.67	6.39	7.07	7.84	7.98	8.00	8.42

Notes:

1. The maximum spans for vibration control, l_v , are increased by 20% for non-structural elements that are considered to provide enhanced vibration effect.
2. If applicable, the concrete topping area density shall not be greater than twice the bare CLT floor area density.
3. The tabulated values apply to simply supported floor slabs.

Roof Slabs – Sizing

Snow load = 1.5 kPa – Simple Span

Layup selection

Dead load ^(a) (kPa)	L (m) ^(b)																				
	2.50	2.75	3.00	3.25	3.50	3.75	4.00	4.25	4.50	4.75	5.00	5.25	5.50	5.75	6.00	6.25	6.50	6.75	7.00		
0.5								89-3s	105-3s	105-3s	105-3s			143-5s	143-5s	143-5s	143-5s	143-5s	175-5s	175-5s	175-5s
1.0					89-3s	89-3s	89-3s	105-3s	105-3s					143-5s	143-5s	143-5s	143-5s	175-5s	175-5s	175-5s	197-7s
1.5				89-3s	89-3s	105-3s	105-3s	105-3s						143-5s	143-5s	143-5s	175-5s	175-5s	175-5s	197-7s	197-7s
2.0			89-3s	89-3s	105-3s	105-3s	105-3s	105-3s						143-5s	143-5s	143-5s	175-5s	175-5s	175-5s	197-7s	197-7s
2.5	89-3s	89-3s	89-3s	89-3s	105-3s	105-3s	105-3s	105-3s						143-5s	143-5s	143-5s	175-5s	175-5s	175-5s	197-7s	197-7s
3.0				105-3s	105-3s	105-3s	105-3s	105-3s						143-5s	143-5s	143-5s	175-5s	175-5s	175-5s	197-7s	197-7s
3.5				105-3s	105-3s	105-3s	105-3s	105-3s						143-5s	143-5s	143-5s	175-5s	175-5s	175-5s	197-7s	197-7s
4.0			105-3s	105-3s	105-3s	105-3s	105-3s	105-3s						143-5s	143-5s	143-5s	175-5s	175-5s	175-5s	197-7s	197-7s
4.5			105-3s	105-3s	105-3s	105-3s	105-3s	105-3s						143-5s	143-5s	143-5s	175-5s	175-5s	175-5s	197-7s	197-7s

Snow load = 1.5 kPa – Double Span

Layup selection

Dead load ^(a) (kPa)	L (m) ^(b)																				
	2.50	2.75	3.00	3.25	3.50	3.75	4.00	4.25	4.50	4.75	5.00	5.25	5.50	5.75	6.00	6.25	6.50	6.75	7.00		
0.5								89-3s	89-3s	89-3s	89-3s	89-3s	89-3s	89-3s	105-3s	105-3s	105-3s	143-5s	143-5s	143-5s	143-5s
1.0					89-3s	89-3s	89-3s	89-3s	89-3s	89-3s	89-3s	89-3s	89-3s	89-3s	105-3s	105-3s	105-3s	143-5s	143-5s	143-5s	143-5s
1.5				89-3s	89-3s	89-3s	89-3s	89-3s	89-3s	89-3s	89-3s	89-3s	89-3s	89-3s	105-3s	105-3s	105-3s	143-5s	143-5s	143-5s	143-5s
2.0			89-3s	89-3s	89-3s	89-3s	89-3s	89-3s	89-3s	89-3s	89-3s	89-3s	89-3s	89-3s	105-3s	105-3s	105-3s	143-5s	143-5s	143-5s	143-5s
2.5	89-3s	89-3s	89-3s	89-3s	89-3s	89-3s	89-3s	89-3s	89-3s	89-3s	89-3s	89-3s	89-3s	89-3s	105-3s	105-3s	105-3s	143-5s	143-5s	143-5s	143-5s
3.0				105-3s	105-3s	105-3s	105-3s	105-3s	105-3s	105-3s	105-3s	105-3s	105-3s	105-3s	105-3s	105-3s	105-3s	143-5s	143-5s	143-5s	143-5s
3.5				105-3s	105-3s	105-3s	105-3s	105-3s	105-3s	105-3s	105-3s	105-3s	105-3s	105-3s	105-3s	105-3s	105-3s	143-5s	143-5s	143-5s	143-5s
4.0			89-3s	89-3s	89-3s	89-3s	89-3s	89-3s	89-3s	89-3s	89-3s	89-3s	89-3s	89-3s	105-3s	105-3s	105-3s	143-5s	143-5s	143-5s	143-5s
4.5			89-3s	89-3s	89-3s	89-3s	89-3s	89-3s	89-3s	89-3s	89-3s	89-3s	89-3s	89-3s	105-3s	105-3s	105-3s	143-5s	143-5s	143-5s	143-5s

a) Specified dead load. The panel self weight is considered in the calculation and shall not be included in the specified dead load.

b) Span is measured centre to centre of supports.

Notes:

- For preliminary design use only. Final design shall include a complete analysis including the verification of the factored bearing resistance. If applicable, the final design shall include a consideration for vibration control and the verification of a concentrated live load as defined in Article 4.1.5.9. of the 2015 NBC.
- Tables are based on uniform loads and dry service conditions, for bending in the major strength direction of the panel. Tables also consider a normal importance category for buildings as defined in Table 4.1.2.1. of the 2015 NBC.
- The ultimate limit states take into account the factored bending moment and shear resistances. The serviceability limit states include a snow load deflection limit of L/240 and a total load deflection limit of L/180.
- Fire-resistance rating takes into account the bending moment and shear resistances of the effective cross-section.
- Fire-resistance rating:

30 min	60 min	90 min	120 min
--------	--------	--------	---------

Snow load = 2.5 kPa – Simple Span

Layup selection

Dead load ^(a) (kPa)	L (m) ^(b)																		
	2.50	2.75	3.00	3.25	3.50	3.75	4.00	4.25	4.50	4.75	5.00	5.25	5.50	5.75	6.00	6.25	6.50	6.75	7.00
0.5																			
1.0					89-3s	89-3s	89-3s	105-3s	105-3s										
1.5			89-3s	89-3s	89-3s	89-3s	105-3s	105-3s											
2.0			89-3s	89-3s	89-3s	89-3s	105-3s	105-3s											
2.5	89-3s	89-3s																	
3.0			89-3s																
3.5			89-3s																
4.0			105-3s																
4.5		89-3s																	

Snow load = 2.5 kPa – Double Span

Layup selection

Dead load ^(a) (kPa)	L (m) ^(b)																		
	2.50	2.75	3.00	3.25	3.50	3.75	4.00	4.25	4.50	4.75	5.00	5.25	5.50	5.75	6.00	6.25	6.50	6.75	7.00
0.5																			
1.0																			
1.5																			
2.0																			
2.5	89-3s	89-3s																	
3.0																			
3.5																			
4.0																			
4.5		89-3s																	

a) Specified dead load. The panel self weight is considered in the calculation and shall not be included in the specified dead load.

b) Span is measured centre to centre of supports.

Notes:

- For preliminary design use only. Final design shall include a complete analysis including the verification of the factored bearing resistance. If applicable, the final design shall include a consideration for vibration control and the verification of a concentrated live load as defined in Article 4.1.5.9. of the 2015 NBC.
- Tables are based on uniform loads and dry service conditions, for bending in the major strength direction of the panel. Tables also consider a normal importance category for buildings as defined in Table 4.1.2.1. of the 2015 NBC.
- The ultimate limit states take into account the factored bending moment and shear resistances. The serviceability limit states include a snow load deflection limit of L/240 and a total load deflection limit of L/180.
- Fire-resistance rating takes into account the bending moment and shear resistances of the effective cross-section.
- Fire-resistance rating:

30 min	60 min	90 min	120 min
--------	--------	--------	---------

Snow load = 3.5 kPa – Simple Span

Layup selection

Dead load ^(a) (kPa)	L (m) ^(b)																		
	2.50	2.75	3.00	3.25	3.50	3.75	4.00	4.25	4.50	4.75	5.00	5.25	5.50	5.75	6.00	6.25	6.50	6.75	7.00
0.5	89-3s	89-3s	89-3s	89-3s	89-3s	89-3s	105-3s	105-3s	143-5s	143-5s	143-5s	143-5s	143-5s	175-5s	175-5s	175-5s	175-5s	197-7s	197-7s
1.0	89-3s	89-3s	89-3s	89-3s	89-3s	105-3s	105-3s	143-5s	143-5s	143-5s	143-5s	143-5s	175-5s	175-5s	197-7s	197-7s	197-7s	197-7s	197-7s
1.5	89-3s	89-3s	89-3s	89-3s	105-3s	105-3s	143-5s	143-5s	143-5s	143-5s	175-5s	175-5s	175-5s	197-7s	197-7s	197-7s	197-7s	213-7l	213-7l
2.0	89-3s	89-3s	89-3s	105-3s	105-3s	143-5s	143-5s	143-5s	143-5s	175-5s	175-5s	175-5s	197-7s	197-7s	197-7s	197-7s	213-7l	213-7l	213-7l
2.5	89-3s	89-3s	105-3s	105-3s	143-5s	143-5s	143-5s	143-5s	175-5s	175-5s	175-5s	197-7s	197-7s	197-7s	197-7s	213-7l	213-7l	213-7l	213-7l
3.0	89-3s	89-3s	105-3s	105-3s	143-5s	143-5s	143-5s	143-5s	175-5s	175-5s	175-5s	197-7s	197-7s	197-7s	197-7s	213-7l	213-7l	213-7l	245-7s
3.5	89-3s	89-3s	105-3s	105-3s	143-5s	143-5s	143-5s	143-5s	175-5s	175-5s	175-5s	197-7s	197-7s	197-7s	197-7s	213-7l	213-7l	245-7s	245-7s
4.0	89-3s	89-3s	105-3s	143-5s	143-5s	143-5s	143-5s	175-5s	175-5s	175-5s	197-7s	197-7s	197-7s	197-7s	213-7l	213-7l	245-7s	245-7s	245-7l
4.5	89-3s	105-3s	105-3s	143-5s	143-5s	143-5s	143-5s	175-5s	175-5s	175-5s	197-7s	197-7s	197-7s	197-7s	213-7l	213-7l	245-7s	245-7l	245-7l

Snow load = 3.5 kPa – Double Span

Layup selection

Dead load ^(a) (kPa)	L (m) ^(b)																		
	2.50	2.75	3.00	3.25	3.50	3.75	4.00	4.25	4.50	4.75	5.00	5.25	5.50	5.75	6.00	6.25	6.50	6.75	7.00
0.5	89-3s	89-3s	89-3s	89-3s	89-3s	89-3s	89-3s	89-3s	89-3s	105-3s	105-3s	105-3s	143-5s	143-5s	143-5s	143-5s	143-5s	143-5s	143-5s
1.0	89-3s	89-3s	89-3s	89-3s	89-3s	89-3s	89-3s	89-3s	105-3s	105-3s	105-3s	143-5s	143-5s	143-5s	143-5s	143-5s	143-5s	143-5s	143-5s
1.5	89-3s	89-3s	89-3s	89-3s	89-3s	89-3s	89-3s	105-3s	105-3s	105-3s	143-5s	143-5s	143-5s	143-5s	143-5s	143-5s	143-5s	143-5s	175-5s
2.0	89-3s	89-3s	89-3s	89-3s	89-3s	89-3s	105-3s	105-3s	105-3s	143-5s	143-5s	143-5s	143-5s	143-5s	143-5s	143-5s	143-5s	175-5s	175-5s
2.5	89-3s	89-3s	89-3s	89-3s	89-3s	89-3s	105-3s	105-3s	105-3s	143-5s	143-5s	143-5s	143-5s	143-5s	143-5s	143-5s	143-5s	175-5s	175-5s
3.0	89-3s	89-3s	89-3s	89-3s	89-3s	89-3s	105-3s	105-3s	105-3s	143-5s	143-5s	143-5s	143-5s	143-5s	143-5s	143-5s	143-5s	175-5s	175-5s
3.5	89-3s	89-3s	89-3s	89-3s	89-3s	89-3s	105-3s	105-3s	105-3s	143-5s	143-5s	143-5s	143-5s	143-5s	143-5s	143-5s	143-5s	175-5s	197-7s
4.0	89-3s	89-3s	89-3s	89-3s	89-3s	89-3s	105-3s	105-3s	105-3s	143-5s	143-5s	143-5s	143-5s	143-5s	143-5s	143-5s	143-5s	175-5s	197-7s
4.5	89-3s	89-3s	89-3s	89-3s	89-3s	89-3s	105-3s	105-3s	105-3s	143-5s	143-5s	143-5s	143-5s	143-5s	143-5s	143-5s	143-5s	175-5s	197-7s

- a) Specified dead load. The panel self weight is considered in the calculation and shall not be included in the specified dead load.
- b) Span is measured centre to centre of supports.

Notes:

1. For preliminary design use only. Final design shall include a complete analysis including the verification of the factored bearing resistance. If applicable, the final design shall include a consideration for vibration control and the verification of a concentrated live load as defined in Article 4.1.5.9. of the 2015 NBC.
2. Tables are based on uniform loads and dry service conditions, for bending in the major strength direction of the panel. Tables also consider a normal importance category for buildings as defined in Table 4.1.2.1. of the 2015 NBC.
3. The ultimate limit states take into account the factored bending moment and shear resistances. The serviceability limit states include a snow load deflection limit of L/240 and a total load deflection limit of L/180.
4. Fire-resistance rating takes into account the bending moment and shear resistances of the effective cross-section.
5. Fire-resistance rating:

30 min	60 min	90 min	120 min
--------	--------	--------	---------

Roof Slabs – Selection Tables

Ultimate Limit States – Factored Bending Moment and Shear Resistances

Maximum factored uniform load (kPa)

L ^(a) (m)	Layup								
	89-3s	105-3s	143-5s	175-5s	197-7s	213-7l	245-7s	245-7l	267-9l
3.0									
3.2	14.13								
3.4	13.26								
3.6	12.49	14.92							
3.8	11.81	14.10							
4.0	11.20	13.36							
4.2	10.65	12.70							
4.4	10.15	12.10							
4.6	9.69	11.55							
4.8	9.28	11.05							
5.0	8.89	10.60	14.42						
5.2	8.28	10.17	13.84						
5.4	7.68	9.79	13.31						
5.6	7.14	9.43	12.81						
5.8	6.66	9.04	12.35						
6.0	6.22	8.44	11.92	14.83					
6.2	5.83	7.91	11.52	14.32					
6.4	5.47	7.42	11.15	13.86					
6.6	5.14	6.98	10.80	13.42					
6.8	4.84	6.57	10.47	13.01	14.56				
7.0	4.57	6.20	10.16	12.62	14.12				
7.2	4.32	5.86	9.87	12.25	13.71	14.93			
7.4	4.09	5.55	9.50	11.91	13.33	14.51			
7.6	3.88	5.26	9.00	11.58	12.96	14.11			
7.8	3.68	5.00	8.55	11.28	12.61	13.73			
8.0	3.50	4.75	8.13	10.98	12.28	13.37			
8.2		4.52	7.73	10.47	11.97	13.03			
8.4		4.31	7.37	9.98	11.68	12.71	14.79	14.79	
8.6		4.11	7.03	9.52	11.40	12.40	14.42	14.42	
8.8		3.93	6.71	9.09	11.13	12.11	14.08	14.08	
9.0		3.75	6.42	8.69	10.87	11.83	13.75	13.75	14.93
9.2		3.59	6.14	8.32	10.63	11.56	13.44	13.44	14.59
9.4			5.89	7.97	10.39	11.30	13.14	13.14	14.27
9.6			5.64	7.64	10.07	11.06	12.86	12.86	13.96
9.8			5.41	7.33	9.66	10.83	12.59	12.59	13.66

Ultimate limit states

- $M_r \geq M_l$
- $V_r \geq V_l$

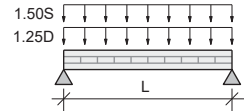
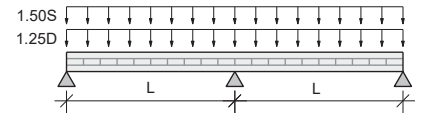

a) Span is measured centre to centre of supports.

Notes:

- For preliminary design use only. Final design shall include a complete analysis including the verification of the factored bending moment, shear, and bearing resistances and a consideration for snow load and total load deflections. If applicable, the final design shall include a consideration for vibration control, the verification of a concentrated live load as defined in Article 4.1.5.9. of the 2015 NBC, and fire-resistance requirements.
- The tabulated values are based on dry service conditions, standard-term duration of load, and the most restrictive of simple span or double span, for bending in the major strength direction of the panel.
- The above values apply to slabs with a specified dead load less or equal to the specified snow load. If the specified dead load is greater than the specified snow load, multiply the maximum factored uniform load by the corresponding adjustment factor:

Adjustment factor based on specified dead load / specified snow load ratio (D/S)

D/S	1.00	1.25	1.50	1.75	2.00	2.25	2.50	2.75	3.00
Factor	1.000	0.952	0.912	0.878	0.849	0.824	0.801	0.780	0.761

Serviceability Limit States – Simple Span, L/180

Maximum specified uniform total load (kPa)

L ^(a) (m)	Layup								
	89-3s	105-3s	143-5s	175-5s	197-7s	213-7l	245-7s	245-7l	267-9l
3.0	6.56	9.88							
3.2	5.46	8.28							
3.4	4.59	7.00							
3.6	3.90	5.97							
3.8		5.13	11.79						
4.0		4.43	10.21						
4.2		3.86	8.89						
4.4			7.79						
4.6			6.87	10.81					
4.8			6.08	9.60					
5.0			5.40	8.56					
5.2			4.83	7.67	11.43				
5.4			4.33	6.89	10.27				
5.6			3.89	6.21	9.26				
5.8			3.52	5.62	8.38				
6.0				5.10	7.61	10.94			
6.2				4.64	6.92	9.97	11.01		
6.4				4.24	6.32	9.11	10.07		
6.6				3.88	5.78	8.34	9.24	11.59	
6.8				3.56	5.30	7.66	8.49	10.67	
7.0					4.87	7.05	7.82	9.84	
7.2					4.49	6.50	7.22	9.10	12.00
7.4					4.15	6.01	6.68	8.42	11.10
7.6					3.84	5.56	6.19	7.81	10.30
7.8					3.56	5.16	5.75	7.26	9.56
8.0						4.80	5.34	6.76	8.90
8.2						4.47	4.98	6.30	8.29
8.4						4.16	4.64	5.88	7.74
8.6						3.89	4.34	5.50	7.23
8.8						3.64	4.06	5.15	6.77
9.0							3.80	4.83	6.35
9.2							3.57	4.53	5.96
9.4								4.26	5.60
9.6								4.01	5.27
9.8								3.78	4.96

Serviceability limit states
• $\Delta_{ST} + \Delta_{LT} K_{creep} \leq L/180$

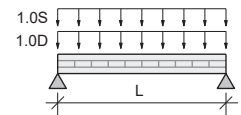

a) Span is measured centre to centre of supports.

Notes:

- For preliminary design use only. Final design shall include a complete analysis including the verification of the factored bending moment, shear, and bearing resistances and a consideration for snow load and total load deflections. If applicable, the final design shall include a consideration for vibration control, the verification of a concentrated live load as defined in Article 4.1.5.9. of the 2015 NBC, and fire-resistance requirements.
- The tabulated values are based on dry service conditions, for bending in the major strength direction of the panel.
- The above values apply to slabs with a specified dead load less or equal to the specified snow load. If the specified dead load is greater than the specified snow load, multiply the maximum specified uniform total load by the corresponding adjustment factor:

Adjustment factor based on specified dead load / specified snow load ratio (D/S)

D/S	1.00	1.25	1.50	1.75	2.00	2.25	2.50	2.75	3.00
Factor	1.000	0.964	0.938	0.917	0.900	0.886	0.875	0.865	0.857

Serviceability Limit States – L/180, Double Span

Maximum specified uniform total load (kPa)

L ^(a) (m)	Layup								
	89-3s	105-3s	143-5s	175-5s	197-7s	213-7l	245-7s	245-7l	267-9l
3.0									
3.2	10.87								
3.4	9.22								
3.6	7.88	11.61							
3.8	6.79	10.07							
4.0	5.88	8.78							
4.2	5.13	7.70							
4.4	4.50	6.78							
4.6	3.97	6.01							
4.8	3.51	5.34							
5.0		4.77	10.94						
5.2		4.27	9.81						
5.4		3.84	8.84						
5.6			7.98						
5.8			7.23	11.23					
6.0			6.57	10.24					
6.2			5.99	9.36					
6.4			5.47	8.58					
6.6			5.01	7.88	11.76				
6.8			4.60	7.25	10.82				
7.0			4.24	6.69	9.98				
7.2			3.91	6.18	9.22				
7.4			3.61	5.72	8.54				
7.6				5.31	7.92	11.31			
7.8				4.93	7.36	10.52	11.54		
8.0				4.59	6.85	9.81	10.76		
8.2				4.28	6.38	9.15	10.06		
8.4				4.00	5.96	8.55	9.41	11.72	
8.6				3.74	5.57	8.00	8.82	11.00	
8.8				3.50	5.21	7.50	8.27	10.33	
9.0					4.89	7.04	7.77	9.72	
9.2					4.59	6.61	7.31	9.15	
9.4					4.31	6.22	6.88	8.62	11.40
9.6					4.06	5.86	6.49	8.14	10.75
9.8					3.82	5.52	6.12	7.69	10.15

Serviceability limit states
 • $\Delta_{ST} + \Delta_{LT} K_{creep} \leq L/180$

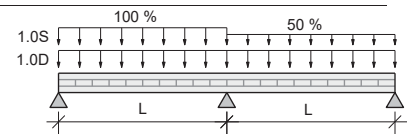

a) Span is measured centre to centre of supports.

Notes:

- For preliminary design use only. Final design shall include a complete analysis including the verification of the factored bending moment, shear, and bearing resistances and a consideration for snow load and total load deflections. If applicable, the final design shall include a consideration for vibration control, the verification of a concentrated live load as defined in Article 4.1.5.9. of the 2015 NBC, and fire-resistance requirements.
- The tabulated values are based on dry service conditions, for bending in the major strength direction of the panel.
- The above values apply to slabs with a specified dead load less or equal to the specified snow load. If the specified dead load is greater than the specified snow load, multiply the maximum specified uniform total load by the corresponding adjustment factor:

Adjustment factor based on specified dead load / specified snow load ratio (D/S)

D/S	1.00	1.25	1.50	1.75	2.00	2.25	2.50	2.75	3.00
Factor	1.000	0.964	0.938	0.917	0.900	0.886	0.875	0.865	0.857

Serviceability Limit States – L/240, Simple Span

Maximum specified uniform snow load (kPa)

L ^(a) (m)	Layup								
	89-3s	105-3s	143-5s	175-5s	197-7s	213-7l	245-7s	245-7l	267-9l
3.0	7.39								
3.2	6.15	9.32							
3.4	5.17	7.88							
3.6	4.39	6.72							
3.8	3.76	5.77							
4.0	3.24	4.99							
4.2	2.81	4.35							
4.4	2.46	3.81	8.77						
4.6	2.16	3.35	7.73						
4.8	1.90	2.96	6.84						
5.0		2.63	6.09	9.64					
5.2		2.35	5.43	8.63					
5.4		2.11	4.87	7.76					
5.6			4.39	7.00					
5.8			3.96	6.33	9.43				
6.0			3.59	5.75	8.56				
6.2			3.26	5.23	7.79				
6.4			2.97	4.77	7.11				
6.6			2.72	4.37	6.51	9.39			
6.8			2.49	4.01	5.97	8.63	9.56		
7.0			2.29	3.69	5.49	7.94	8.81		
7.2			2.10	3.40	5.06	7.32	8.13		
7.4			1.94	3.14	4.67	6.77	7.52	9.48	
7.6				2.90	4.32	6.27	6.97	8.80	
7.8				2.69	4.01	5.81	6.47	8.18	
8.0				2.50	3.72	5.40	6.02	7.61	
8.2				2.33	3.46	5.03	5.61	7.10	9.33
8.4				2.17	3.23	4.69	5.23	6.63	8.71
8.6				2.02	3.01	4.38	4.89	6.20	8.14
8.8					2.81	4.10	4.57	5.80	7.62
9.0					2.63	3.84	4.29	5.44	7.15
9.2					2.47	3.60	4.02	5.11	6.71
9.4					2.32	3.38	3.78	4.80	6.30
9.6					2.18	3.18	3.55	4.52	5.93
9.8					2.05	2.99	3.35	4.26	5.59

Serviceability limit states
• $\Delta_s \leq L/240$

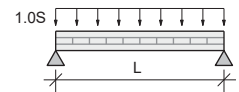

a) Span is measured centre to centre of supports.

Notes:

- For preliminary design use only. Final design shall include a complete analysis including the verification of the factored bending moment, shear, and bearing resistances and a consideration for snow load and total load deflections. If applicable, the final design shall include a consideration for vibration control, the verification of a concentrated live load as defined in Article 4.1.5.9. of the 2015 NBC, and fire-resistance requirements.
- The tabulated values are based on dry service conditions, for bending in the major strength direction of the panel.

Serviceability Limit States – L/240, Double Span

Maximum specified uniform snow load (kPa)

L ^(a) (m)	Layup								
	89-3s	105-3s	143-5s	175-5s	197-7s	213-7l	245-7s	245-7l	267-9l
3.0									
3.2									
3.4	8.81								
3.6	7.51								
3.8	6.46	9.68							
4.0	5.59	8.42							
4.2	4.87	7.37							
4.4	4.27	6.48							
4.6	3.76	5.73							
4.8	3.32	5.09							
5.0	2.96	4.54							
5.2	2.64	4.06	9.34						
5.4	2.37	3.65	8.40						
5.6	2.13	3.29	7.58						
5.8	1.92	2.98	6.86						
6.0		2.70	6.23	9.78					
6.2		2.46	5.67	8.93					
6.4		2.24	5.18	8.18					
6.6		2.05	4.74	7.50					
6.8			4.35	6.90					
7.0			4.00	6.36	9.48				
7.2			3.69	5.87	8.75				
7.4			3.41	5.43	8.10				
7.6			3.15	5.04	7.50				
7.8			2.92	4.68	6.97				
8.0			2.72	4.35	6.48	9.32			
8.2			2.53	4.05	6.04	8.69	9.59		
8.4			2.36	3.78	5.63	8.12	8.97		
8.6			2.20	3.53	5.26	7.59	8.39		
8.8			2.06	3.31	4.93	7.11	7.87	9.87	
9.0			1.92	3.10	4.62	6.67	7.39	9.28	
9.2				2.91	4.33	6.26	6.94	8.73	
9.4				2.73	4.07	5.89	6.53	8.22	
9.6				2.57	3.83	5.54	6.15	7.75	
9.8				2.42	3.61	5.22	5.80	7.32	9.64

Serviceability limit states
• $\Delta_s \leq L/240$

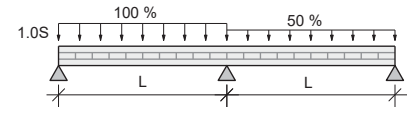

a) Span is measured centre to centre of supports.

Notes:

- For preliminary design use only. Final design shall include a complete analysis including the verification of the factored bending moment, shear, and bearing resistances and a consideration for snow load and total load deflections. If applicable, the final design shall include a consideration for vibration control, the verification of a concentrated live load as defined in Article 4.1.5.9. of the 2015 NBC, and fire-resistance requirements.
- The tabulated values are based on dry service conditions, for bending in the major strength direction of the panel.

Walls – Design Properties

Walls – Design Properties

CLT stress grade	E1 (L = 1950 F _b -1.7E S-P-F MSR and T = No. 3/Stud S-P-F)								
Layup	89-3s	105-3s	143-5s	175-5s	197-7s	213-7l	245-7s	245-7l	267-9l
Loading parallel to outermost layers									
Compression in the major strength direction									
Compressive resistance, $P_{r,0}$ (kN/m) ^(a)	1 081	1 081	1 621	1 621	2 162	2 702	2 162	2 702	3 242
Effective cross-sectional area, $A_{\text{eff},0}$ (10^3 mm ² /m)	70	70	105	105	140	175	140	175	210
Effective out-of-plane moment of inertia, $I_{\text{eff},0}$ (10^8 mm ⁴ /m)	58	93	216	354	526	778	872	1 133	1 478
Effective out-of-plane radius of gyration, $r_{\text{eff},0}$ (mm/m)	29	36	45	58	61	67	79	80	84
Bending in the major strength direction									
Flatwise bending moment resistance, $M_{r,f,0}$ (kN-m/m) ^(b)	28	38	65	88	116	158	155	200	239
Flatwise shear resistance, $V_{r,f,0}$ (kN/m) ^(c)	27	32	43	53	59	64	74	74	80
Effective flatwise bending stiffness, $(EI)_{\text{eff},f,0}$ (10^9 N-mm ² /m)	683	1 088	2 531	4 166	6 194	9 117	10 306	13 279	17 327
Effective shear stiffness in flatwise bending, $(GA)_{\text{eff},f,0}$ (10^6 N/m)	7.6	7.3	15	15	23	25	22	22	32
Loading perpendicular to outermost layers									
Compression in the minor strength direction									
Compressive resistance, $P_{r,90}$ (kN/m) ^(a)	138	252	275	504	413	275	756	504	413
Effective cross-sectional area, $A_{\text{eff},90}$ (10^3 mm ² /m)	19	35	38	70	57	38	105	70	57
Effective out-of-plane moment of inertia, $I_{\text{eff},90}$ (10^6 mm ⁴ /m)	0.58	3.6	29	93	114	29	354	93	114
Effective out-of-plane radius of gyration, $r_{\text{eff},90}$ (mm/m)	5.5	10	28	36	45	28	58	36	45
Bending in the minor strength direction									
Flatwise bending moment resistance, $M_{r,f,90}$ (kN-m/m) ^(b)	0.38	1.3	5.0	11	11	5.0	26	11	11
Flatwise shear resistance, $V_{r,f,90}$ (kN/m) ^(c)	5.7	11	22	32	38	22	53	32	38
Effective flatwise bending stiffness, $(EI)_{\text{eff},f,90}$ (10^9 N-mm ² /m)	5.2	32	263	837	1 045	263	3 220	837	1 045
Effective shear stiffness in flatwise bending, $(GA)_{\text{eff},f,90}$ (10^6 N/m)	5.7	9.1	11	18	17	14	27	20	19

a) The factored compressive resistance under axial load, P_r , include the resistance factor, ϕ . Furthermore, these values shall be adjusted by the size and slenderness factors, K_{Zc} and K_C , respectively, as defined in CSA O86:19.

b) The factored flatwise bending moment resistance values, $M_{r,f}$, include the resistance factor, ϕ , and the adjustment factor K_{tb} as defined in CSA O86:19.

c) The factored flatwise shear resistance values, $V_{r,f}$, include the resistance factor, ϕ .

Notes:

- The tabulated design values are for dry service conditions and standard-term duration of load.
- The compressive resistance perpendicular to grain values shall be based on S-P-F No. 3/Stud lumber ($f_{cp} = 5.3$ MPa).
- The specific gravity for dowel-type fastener design, G , is 0.42.
- The density for member weight is 515 kg/m³ (5.1 kN/m³) for a moisture content of 12%.
- Design of CLT members shall be in accordance with CSA O86:19.

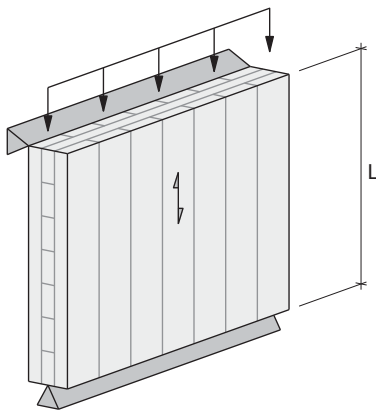

Loading parallel to outermost layers

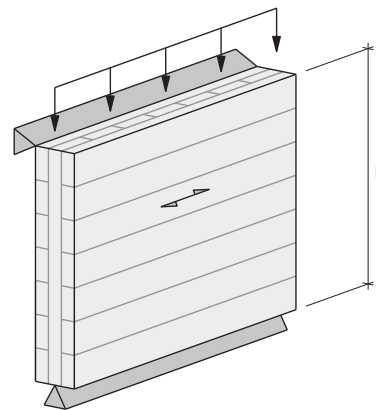

Loading perpendicular to outermost layers

Shear Walls, Lintels, and Diaphragms – Design Properties

Shear Walls, Lintels, and Diaphragms – Design Properties

CLT stress grade	E1 (L = 1950 F _b -1.7E S-P-F MSR and T = No. 3/Stud S-P-F)								
Layup	89-3s	105-3s	143-5s	175-5s	197-7s	213-7l	245-7s	245-7l	267-9l
Loading parallel to outermost layers									
Edgewise bending in the minor strength direction									
Effective width in edgewise bending, $b_{\text{eff},e,90}$ (mm) ^(a)	19	35	38	70	57	38	105	70	57
Specified edgewise shear strength, $f_{v,e,90}$ (MPa) ^(b)	2.4	2.4	2.7	2.7	2.7	2.7	2.7	2.7	2.7
Shear stiffness in edgewise bending, $G_{e,90}t_p$ (10 ⁶ N/m) ^(c)	22	26	36	44	49	53	61	61	67
Loading perpendicular to outermost layers									
Edgewise bending in the major strength direction									
Effective width in edgewise bending, $b_{\text{eff},e,0}$ (mm) ^(a)	70	70	105	105	140	175	140	175	210
Specified edgewise shear strength, $f_{v,e,0}$ (MPa) ^(b)	2.0	2.0	2.4	2.4	2.0	2.4	2.4	2.4	2.0
Shear stiffness in edgewise bending, $G_{e,0}t_p$ (10 ⁶ N/m) ^(c)	22	26	36	44	49	53	61	61	67

- a) The factored edgewise bending moment resistance, $M_{r,e}$, and the effective edgewise bending stiffness, $(EI)_{\text{eff},e}$, values shall be based on the effective width in edgewise bending and depth of the panel, $b_{\text{eff},e}$ and d (see table above and figures below), respectively, and Clause 7.5.6.5 of CSA O86:19. Calculations shall be based on S-P-F No. 3/Stud lumber ($f_b = 7.0$ MPa, $E = 9\,000$ MPa) for loading parallel to outermost layers, or on S-P-F MSR 1950 F_b-1.7E lumber ($f_b = 28.2$ MPa, $E = 11\,700$ MPa) for loading perpendicular to outermost layers.
- b) The factored edgewise shear resistance values, $V_{r,e}$, shall be based on Clause 7.5.7.3b) of CSA O86:19, taking into account the gross cross-sectional area of the panel and using the specified edgewise shear strength, $f_{v,e}$.
- c) $G_{e,0}$ and $G_{e,90} = 250$ MPa based on product performance testing. Shear stiffness in edgewise bending, $(GA)_{\text{eff},e}$, shall be calculated by multiplying G_{e,t_p} by the member depth, d (see figures below).

Notes:

- The tabulated design values are for dry service conditions and standard-term duration of load.
- The compressive resistance perpendicular to grain values shall be based on S-P-F No. 3/Stud lumber ($f_{cp} = 5.3$ MPa).
- The specific gravity for dowel-type fastener design, G , is 0.42.
- The density for member weight is 515 kg/m^3 (5.1 kN/m^3) for a moisture content of 12%.
- Design of CLT members shall be in accordance with CSA O86:19.

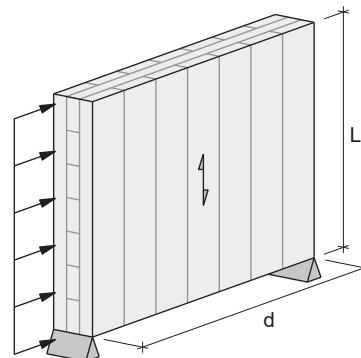
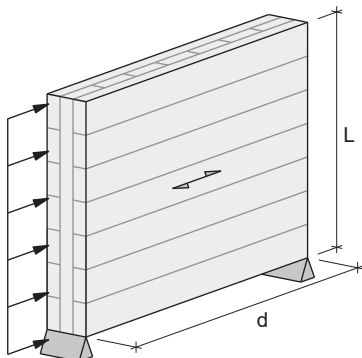
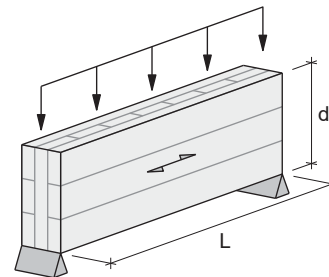
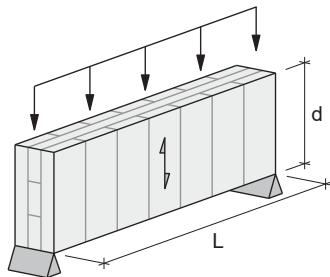

Loading parallel to outermost layers

Loading perpendicular to outermost layers

NORDIC

TECHNICAL GUIDE
NORDIC X-LAM

NS-GT6 

ENGLISH

VERSION
2026-02-01

STRUCTURAL
DETAILS

3



GENERAL NOTES

1.0 General

- 1.1 This document supersedes all previous versions. For the latest version, consult nordic.ca or contact Nordic Structures.
- 1.2 The information contained in this document is provided for information purposes only. This information should not be used for any application without examination and verification of its accuracy, suitability and applicability by a licensed engineer, architect or other professional. Nordic Structures does not guarantee that the information is suitable for any general or particular use, and assumes no responsibility for the use, application of and/or reference to the information.
- 1.3 All dimensions are in millimetres (mm), unless otherwise noted.
- 1.4 For more information, consult nordic.ca or contact Nordic Structures.

2.0 Design of connections

- 2.1 The design of connections, including fire resistance if required, shall be in accordance with CSA O86-14, Engineering design in wood.
- 2.2 The design of connections should include considerations for structural and service performance, such as resistance, minimum distances, dimensional changes, durability, erection and fire safety, among others, as well as taking into account architectural requirements.
- 2.3 The connections shown in this document are provided for information purposes only, and conceptually. Note that many possibilities and variants are possible.

Structure, GL-CLT

Continuous Floor Slab on Beam

NS-DS2001

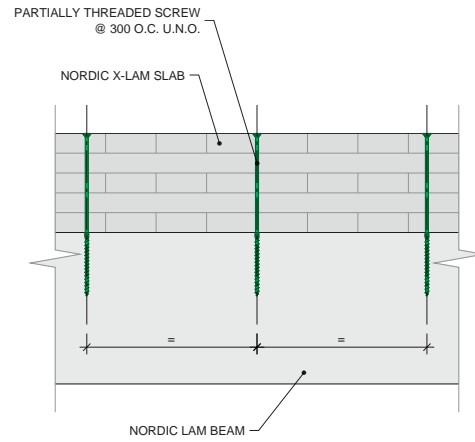
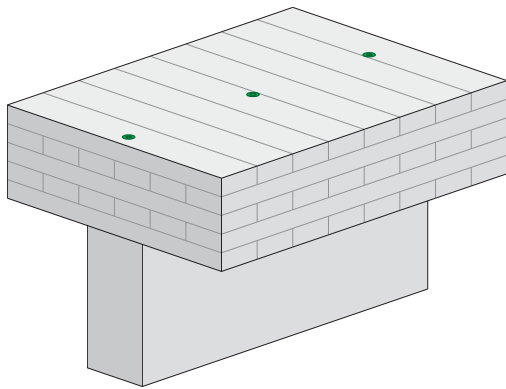

Structure, GL-CLT

Single Floor Slab on Beam

NS-DS2002

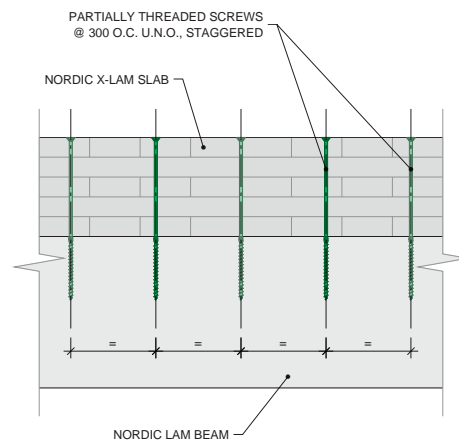
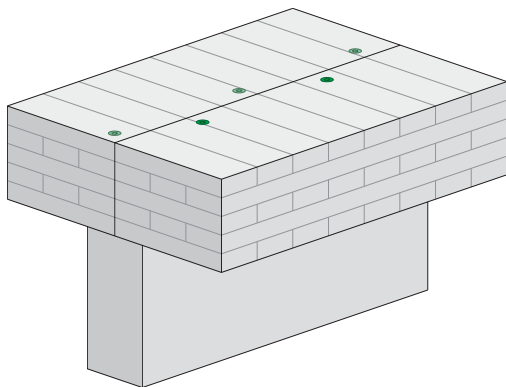

Structure, GL-CLT

Face-mount Hanger

NS-DS2003

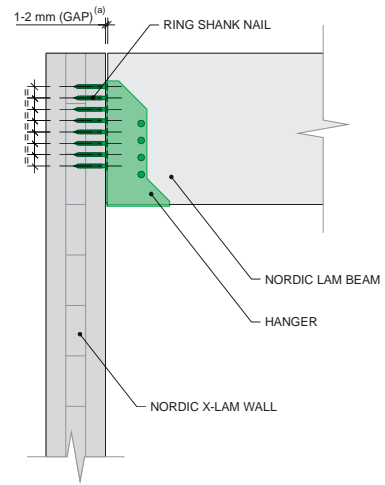
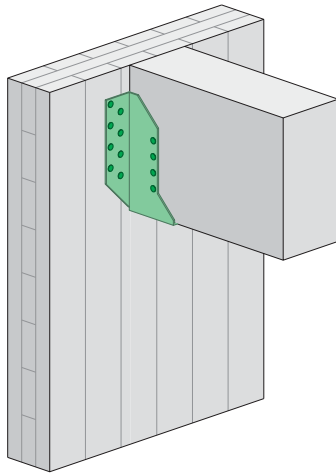

a) The 1-2 mm gap may not be required depending on the detail on the other side of the beam.

Structure, GL-CLT

Face-mount Hanger with Concealed Flanges

NS-DS2067

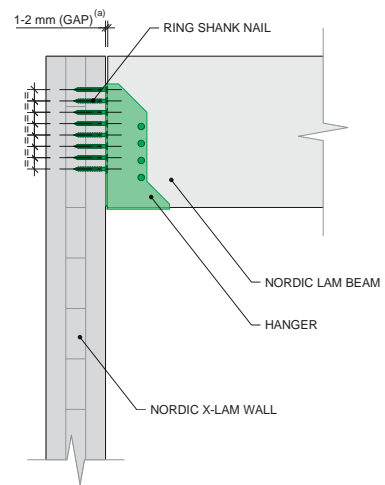
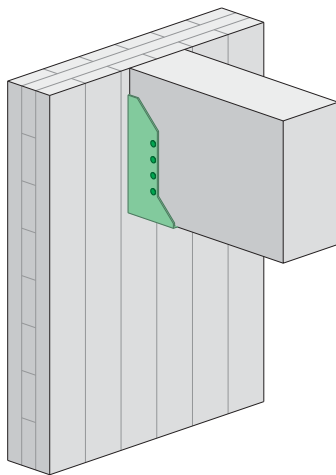

a) The 1-2 mm gap may not be required depending on the detail on the other side of the beam.

Structure, GL-CLT

Knife Plate

NS-DS2004

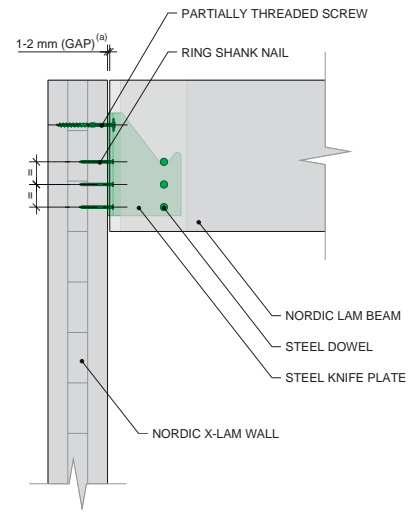
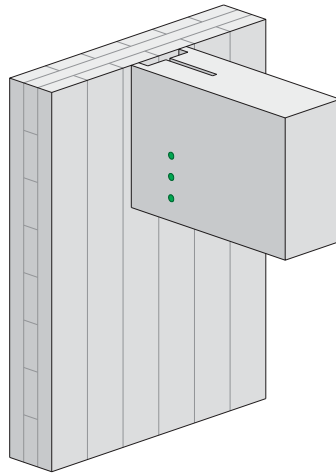

a) The 1-2 mm gap may not be required depending on the detail on the other side of the beam.

Structure, GL-CLT

Knife Plate with Cap

NS-DS2005

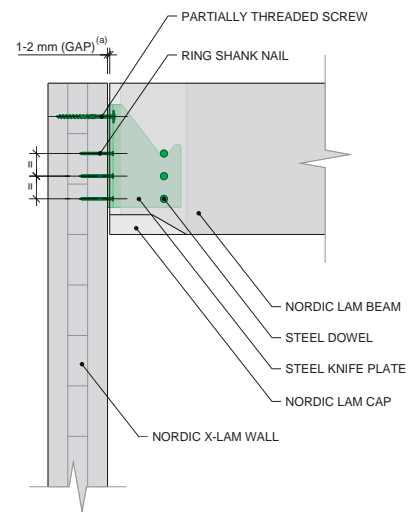
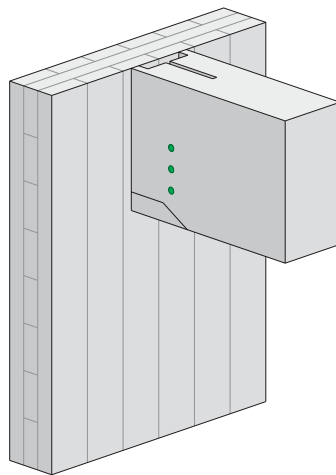

a) The 1-2 mm gap may not be required depending on the detail on the other side of the beam.

Structure, GL-CLT

Screwed Beam to Column

NS-DS2006

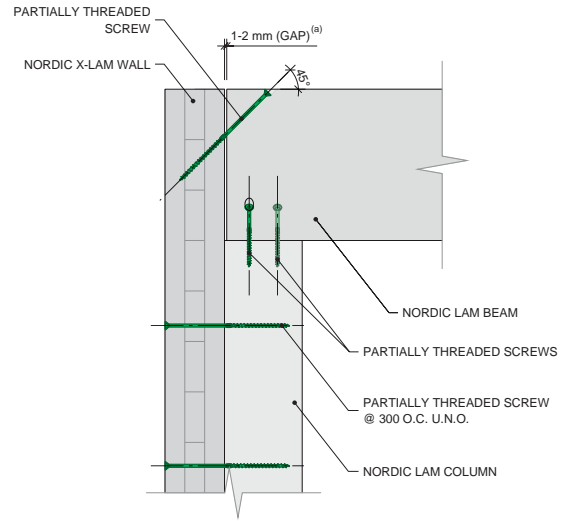
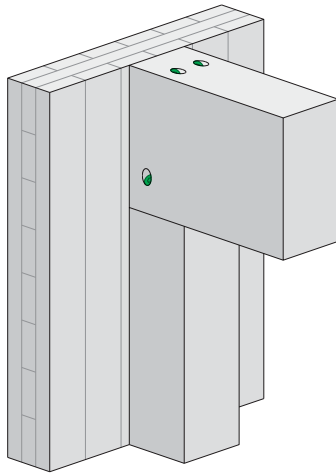

a) The 1-2 mm gap may not be required depending on the detail on the other side of the beam.

Structure, GL-CLT

Beam to Column with Knife Plate

NS-DS2007

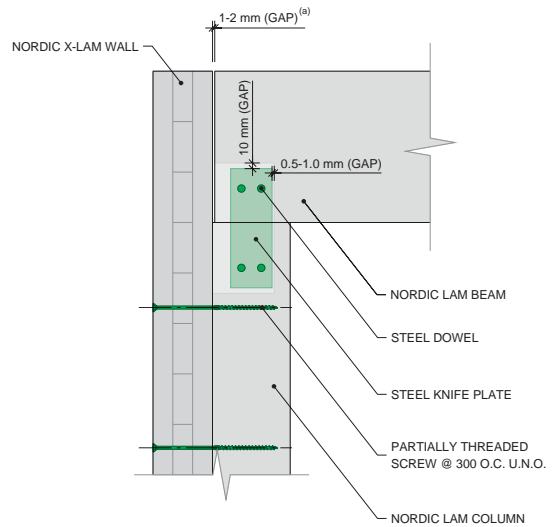
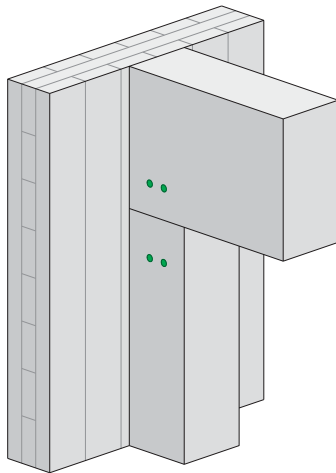

a) The 1-2 mm gap may not be required depending on the detail on the other side of the beam.

Structure, GL-CLT

Pocket for Beam

NS-DS2008

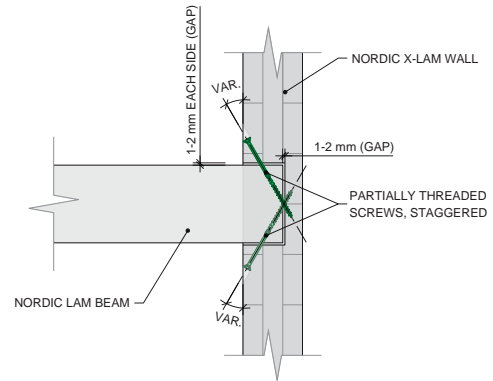
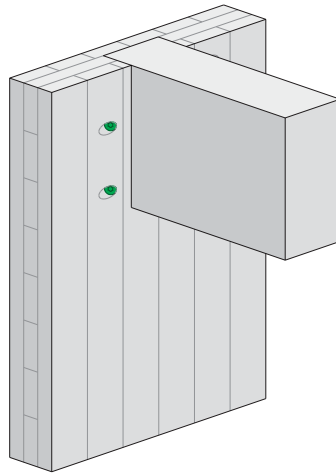

Structure, GL-CLT

Through Pocket for Beam

NS-DS2009

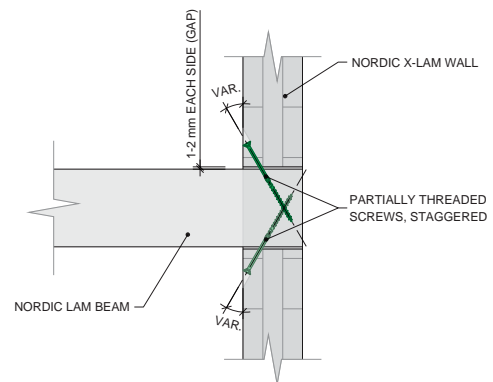
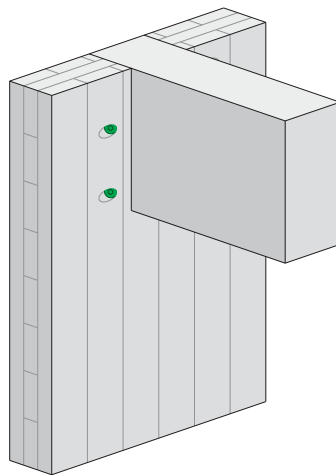

Structure, Wall-Foundation

Wall to Sill Plate, Screws

NS-DS2010

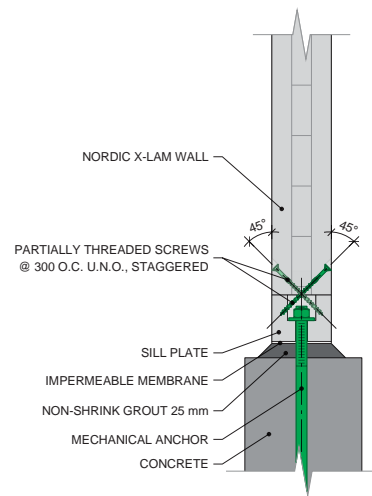
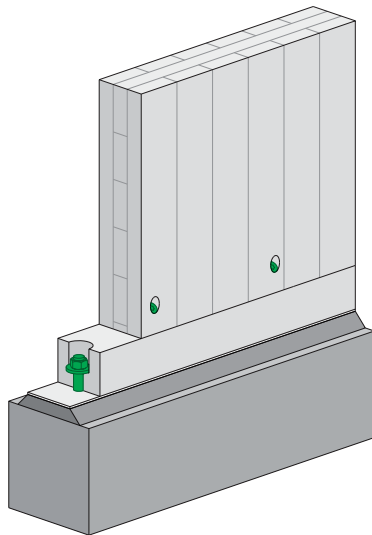

Structure, Wall-Foundation

Wall to Sill Plate, Nailed Steel Plate

NS-DS2011

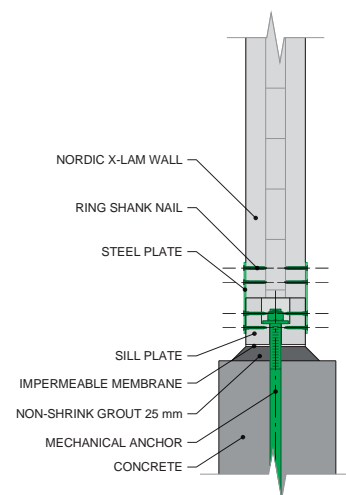
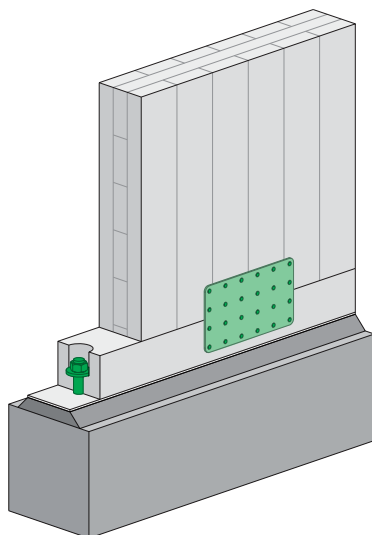

Structure, Wall-Foundation

Wall to Sill Plate, Holdown

NS-DS2012

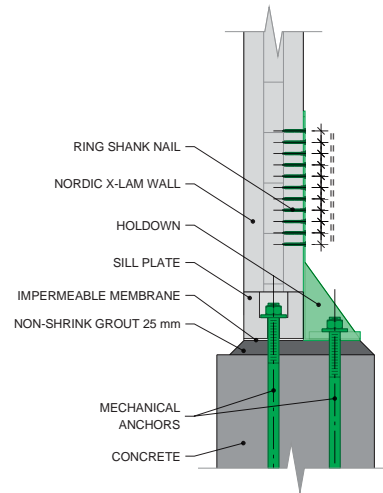
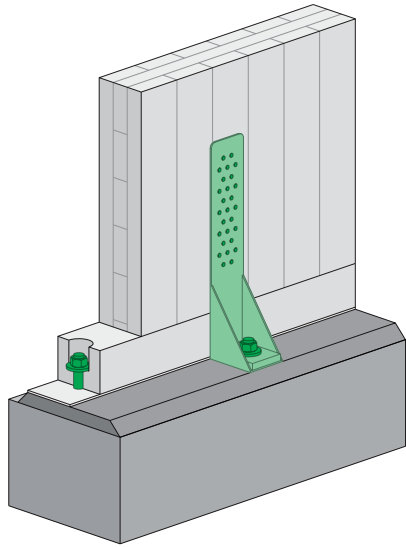

Structure, Wall-Foundation

Wall to Sill Plate, Steel Angle

NS-DS2013

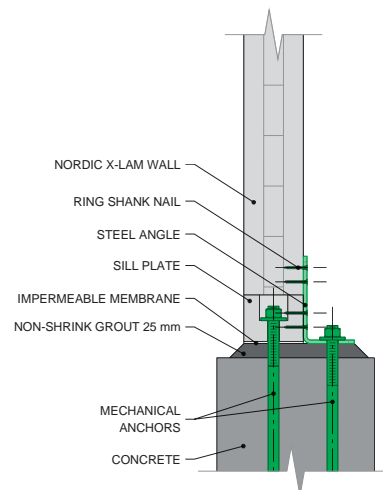
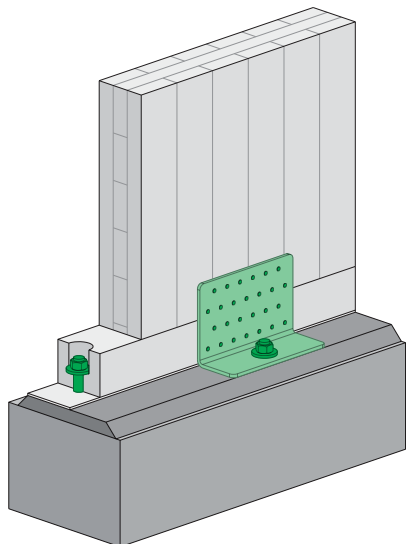

Structure, Wall-Foundation

Wall to Foundation, Holdown

NS-DS2014

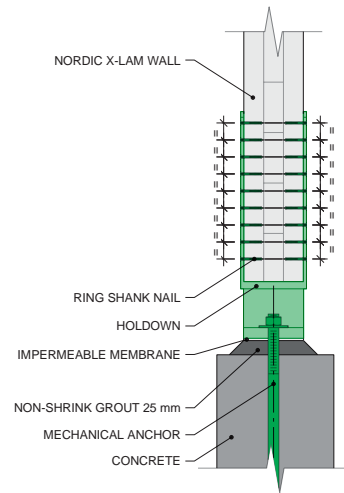
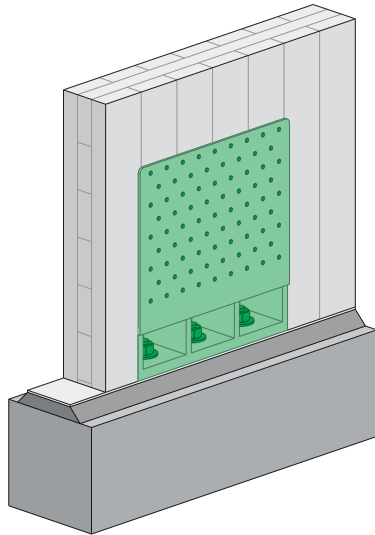

Structure, Wall-Foundation

Wall to Foundation, Nailed Steel Angle

NS-DS2015

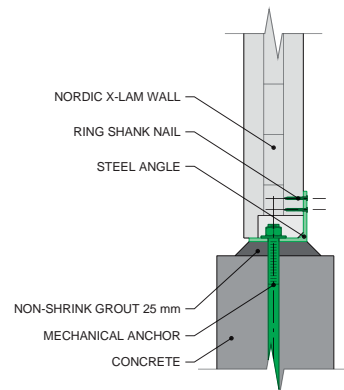
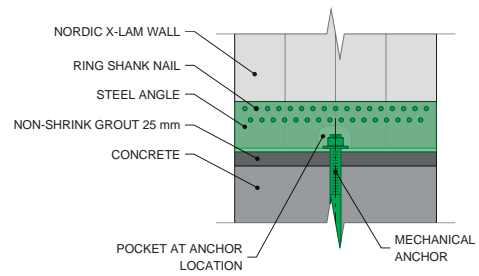
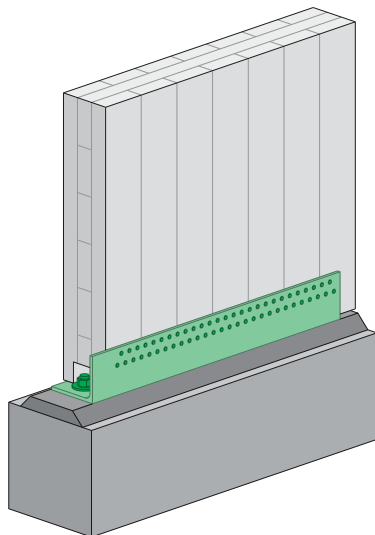

Structure, Wall-Foundation

Wall to Foundation, Screwed Steel Angle

NS-DS2016

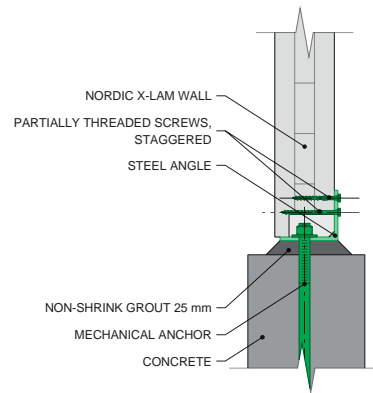
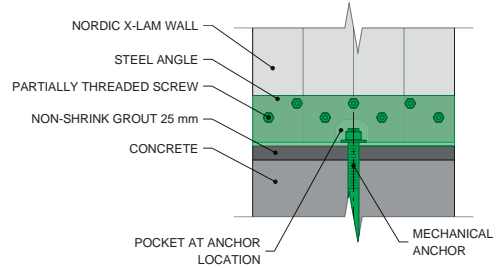
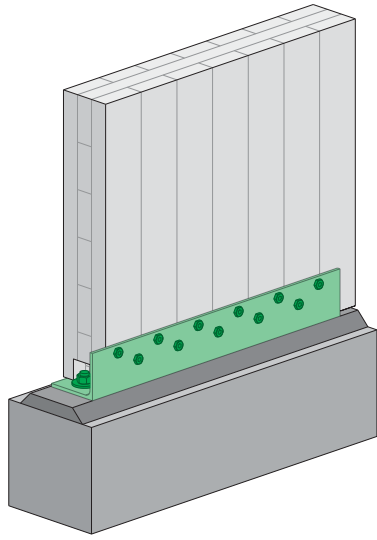

Note:
1. This assembly detail offers a resistance to forces acting perpendicularly to the foundation wall.

Structure, Wall-Foundation

Wall to Foundation, Nailed Steel Angle and Steel C Shape

NS-DS2068

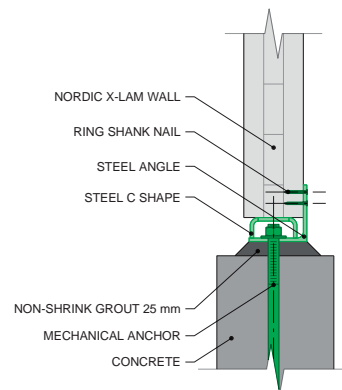
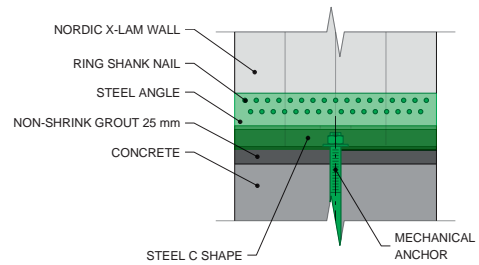
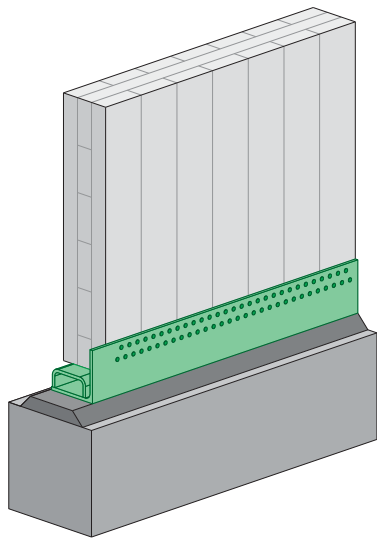

Structure, Wall-Foundation

Wall to Foundation, Nailed C Shape

NS-DS2017

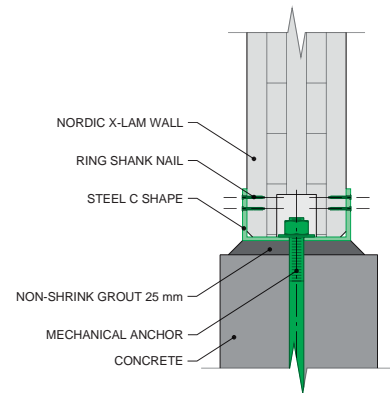
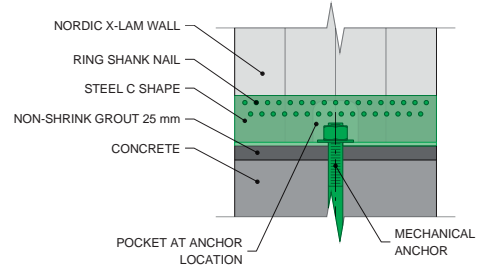
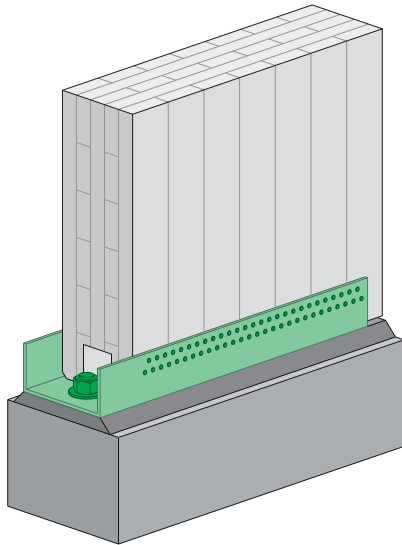

Note:

1. For an exterior wall on foundation, careful consideration should be given to waterproofing and drainage at the junction between wall and steel C shape.

Structure, Floor/Roof-Wall

Ledger

NS-DS2018

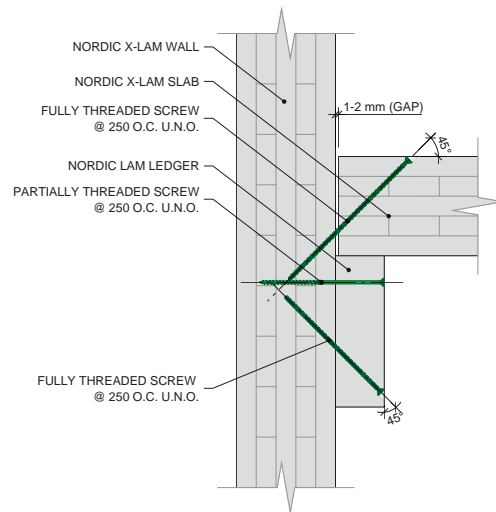
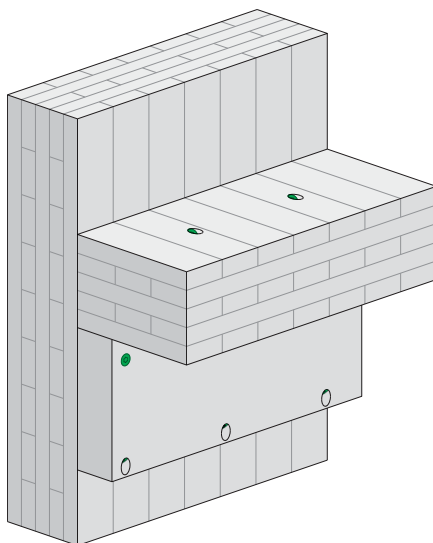

Structure, Floor/Roof-Wall

Steel Angle

NS-DS2019

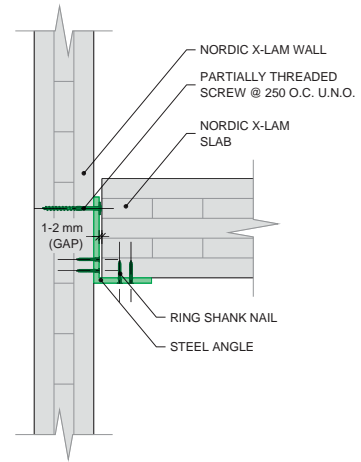
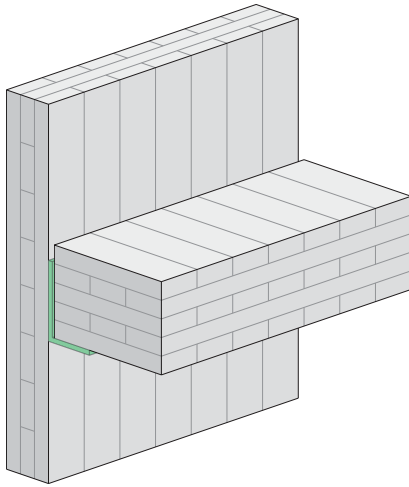

Structure, Floor/Roof-Wall

Screwed Floor/Roof Slab to Wall

NS-DS2020

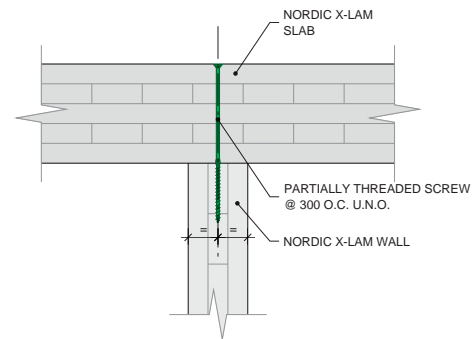
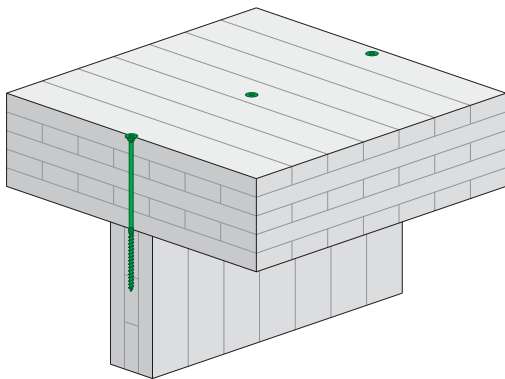

Structure, Floor/Roof-Wall

Screwed Wall to Continuous Floor Slab to Wall

NS-DS2021

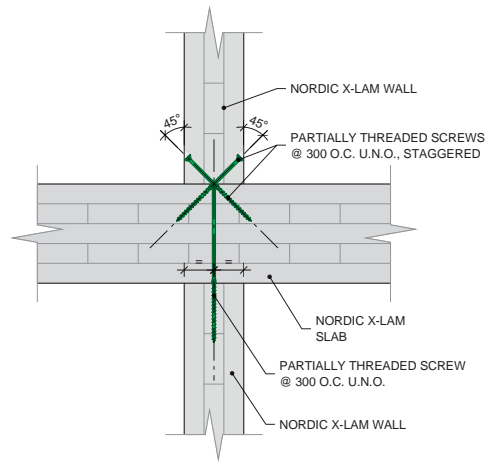
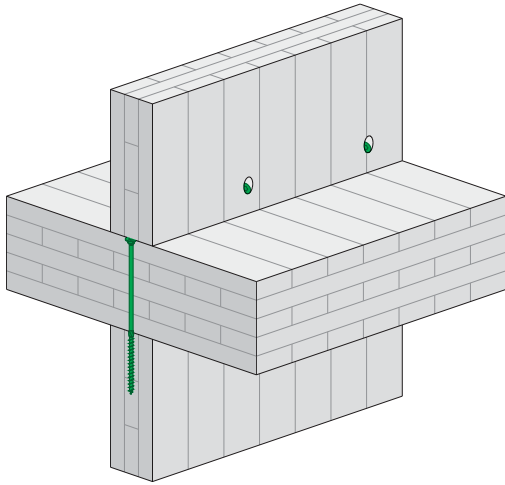

Structure, Floor/Roof-Wall

Screwed Wall to Single Floor Slab to Wall

NS-DS2022

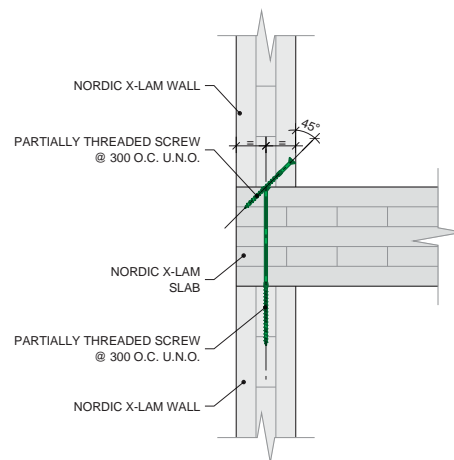
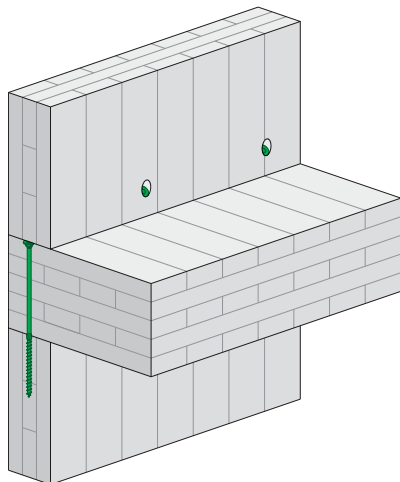

Structure, Floor/Roof-Wall

Wall to Floor Slab with Steel Square to Wall

NS-DS2023

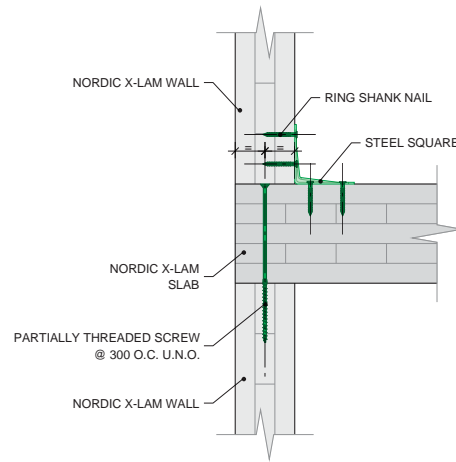
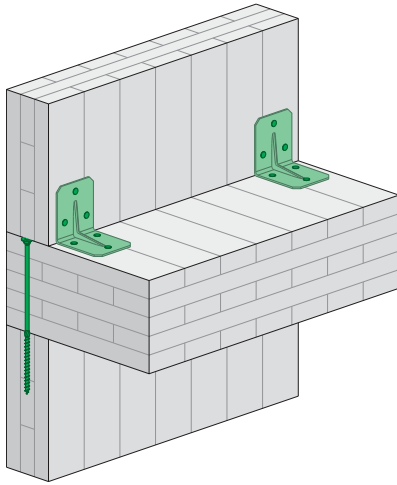

Structure, Floor/Roof-Wall

Wall to Floor Slab with Steel Square to Notched Wall

NS-DS2024

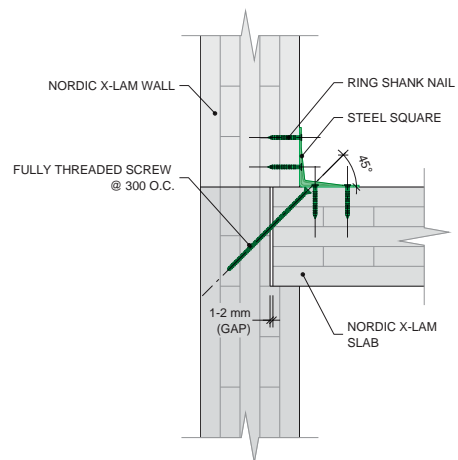
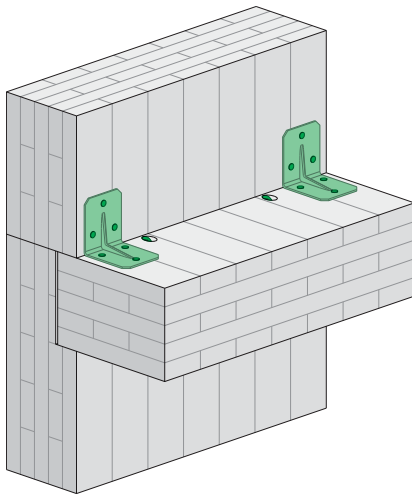

Structure, Floor/Roof-Wall

Sloped Roof Slab to Wall

NS-DS2025

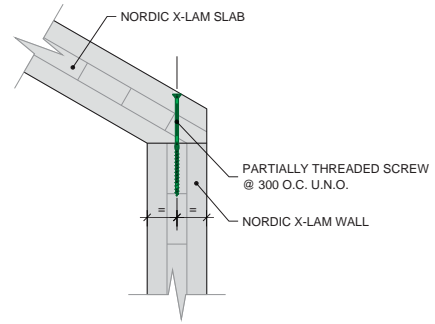
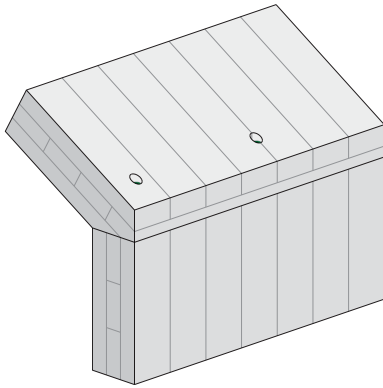

Structure, Lintel

CLT Lintel

NS-DS2026

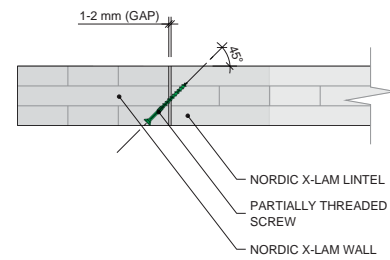
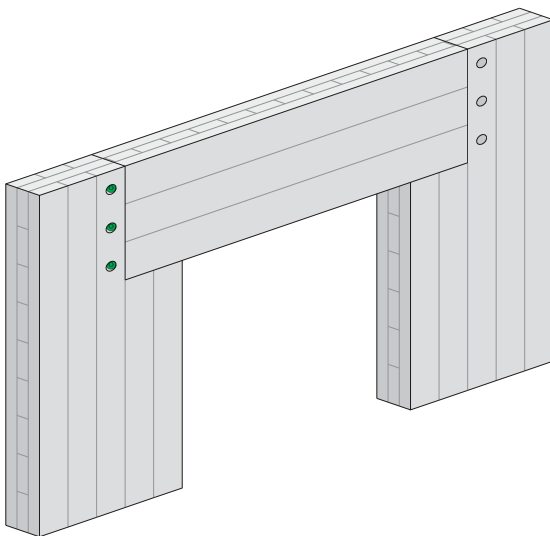

Structure, Lintel

Glulam Lintel

NS-DS2027

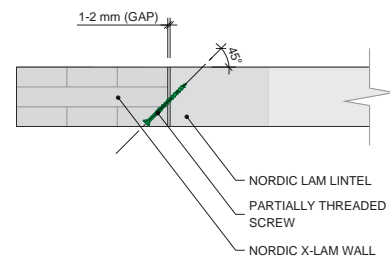
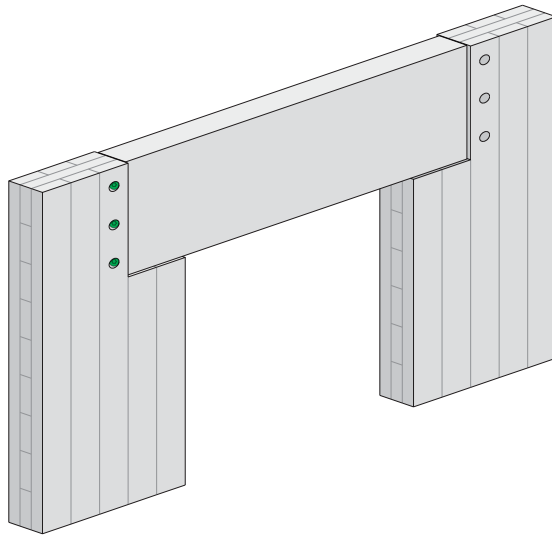

Structure, Panel-Panel

Butt Joint, One Row of Nails

NS-DS2029

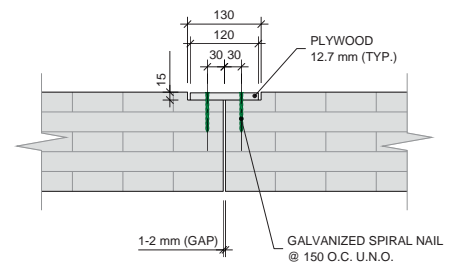
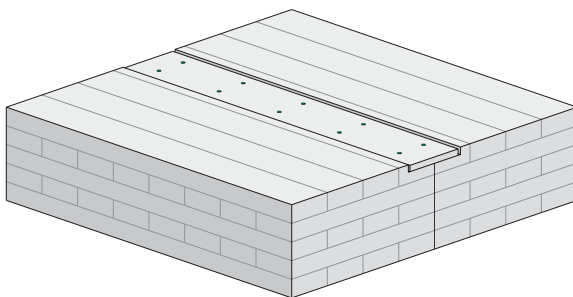

Structure, Panel-Panel

Butt Joint, Two Rows of Nails

NS-DS2030

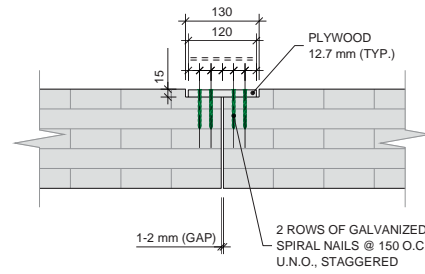
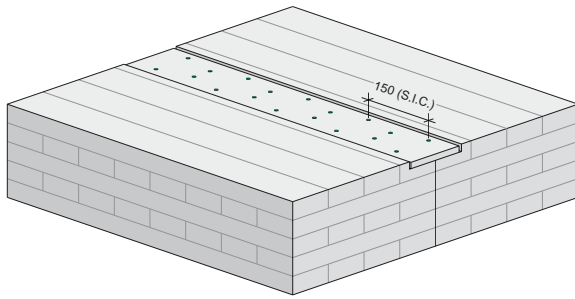

Structure, Panel-Panel

Butt Joint, 45° Screws

NS-DS2069

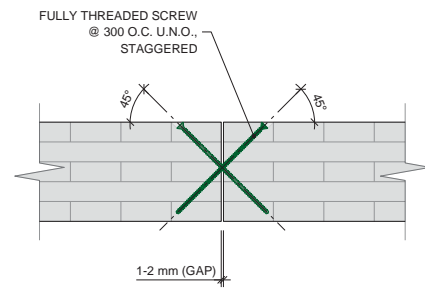
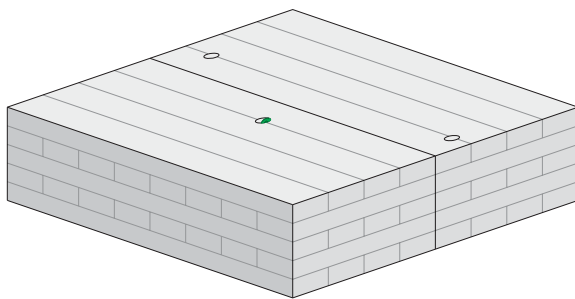

Structure, Panel-Panel

Half-lap Joint

NS-DS2031

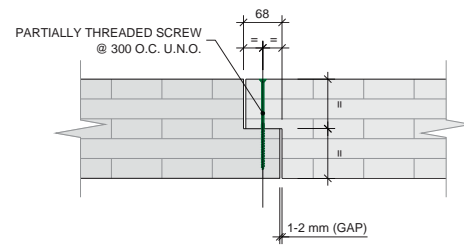
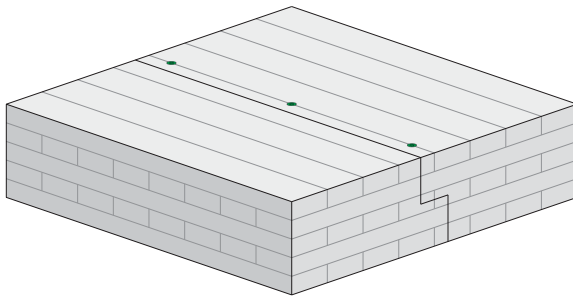

Structure, Wall-Wall

Corner Joint with 90° Screws

NS-DS2032

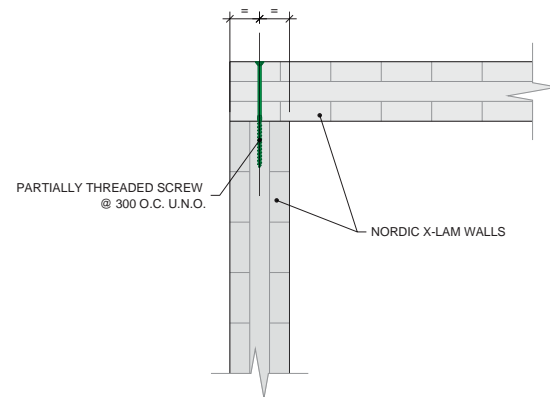
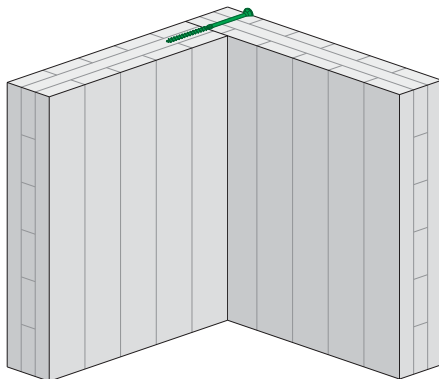

Structure, Wall-Wall

Notched Corner Joint with 90° Screws

NS-DS2033

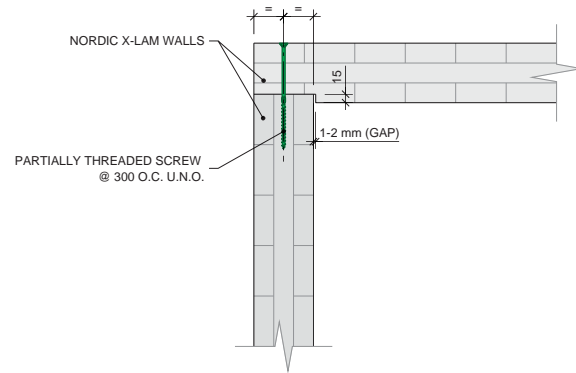
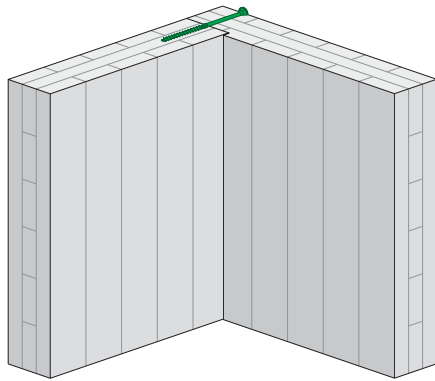

Structure, Wall-Wall

Corner Joint with 45° Screws

NS-DS2034

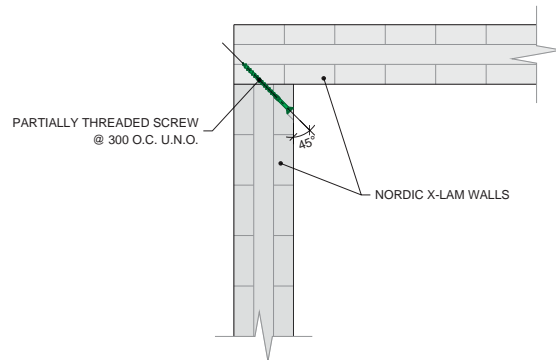
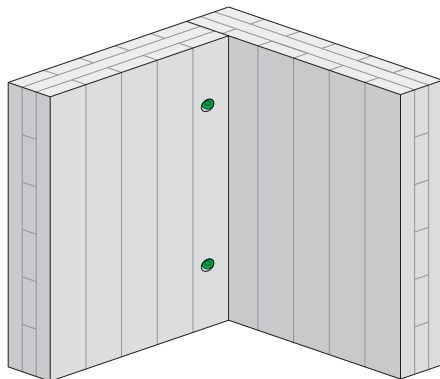

Structure, Wall-Wall

T-joint with 90° Screws

NS-DS2035

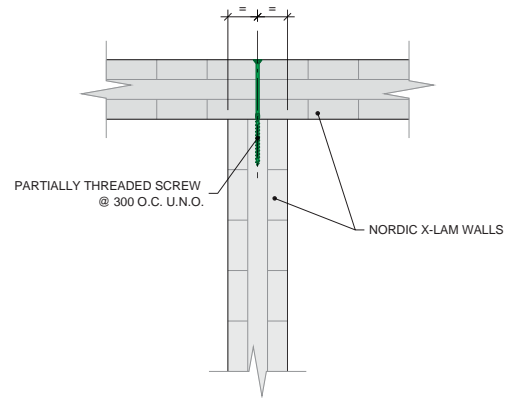
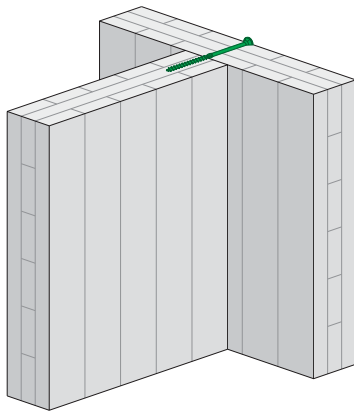

Structure, Wall-Wall

T-joint with 45° Screws

NS-DS2036

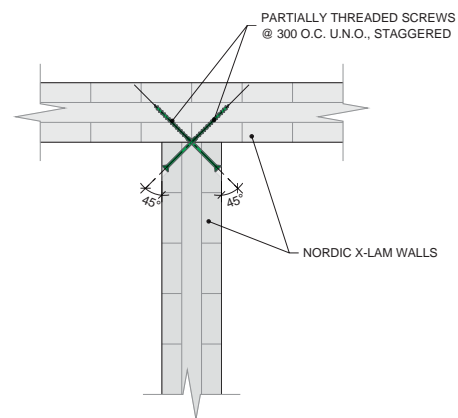
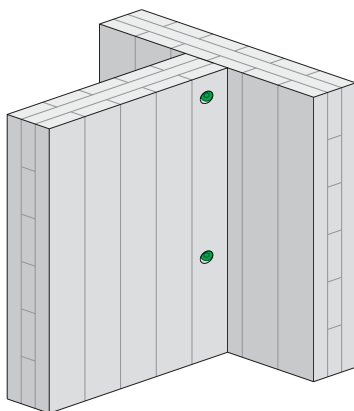

Mechanical, Electrical, and Plumbing

Vertical, Double-member Beam

NS-DS2501

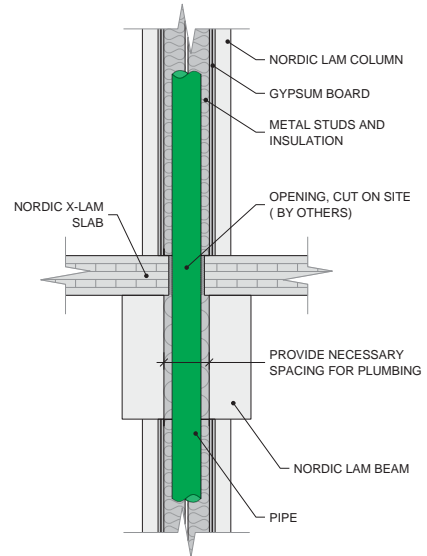
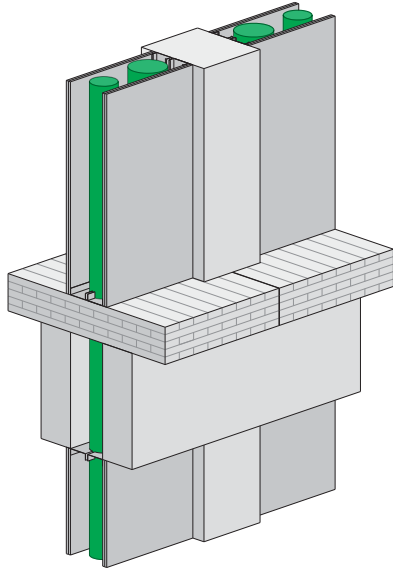

Mechanical, Electrical, and Plumbing

Horizontal, Pre-machined Opening

NS-DS2502

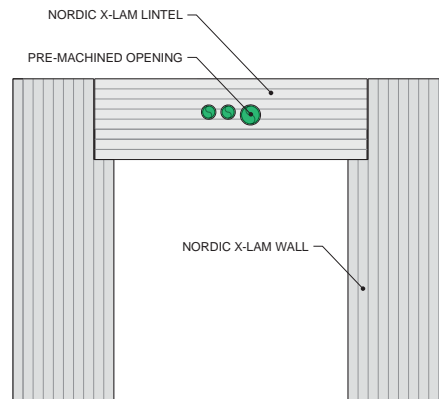
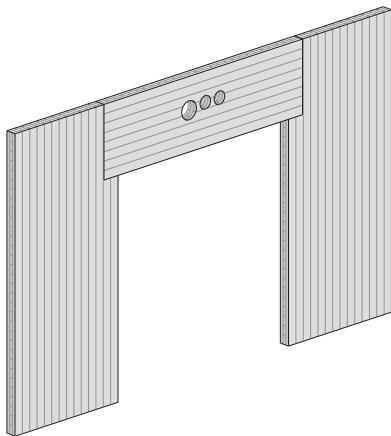

Mechanical, Electrical, and Plumbing

Horizontal, Electrical Box with 38 mm x 64 mm Wood Studs

NS-DS2503

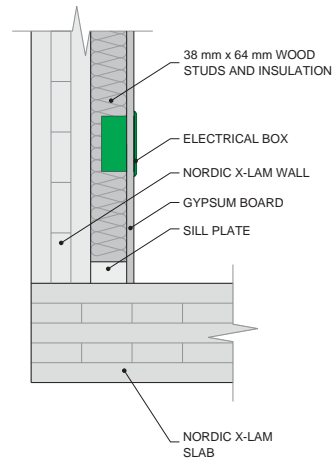
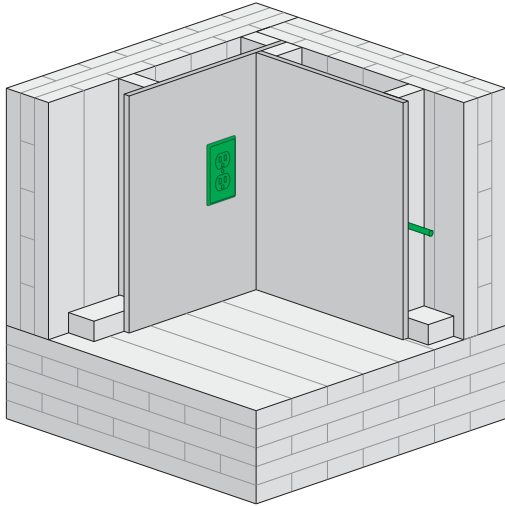

Mechanical, Electrical, and Plumbing

Horizontal, Raised Floor

NS-DS2504

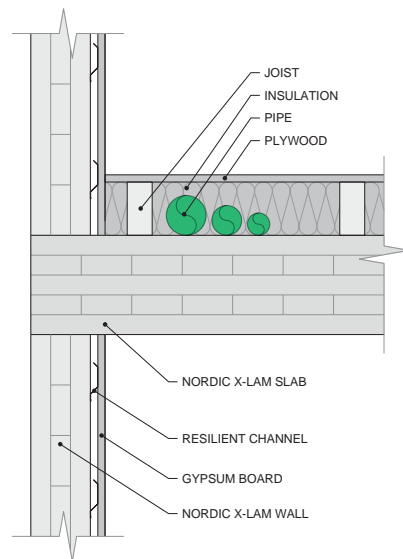
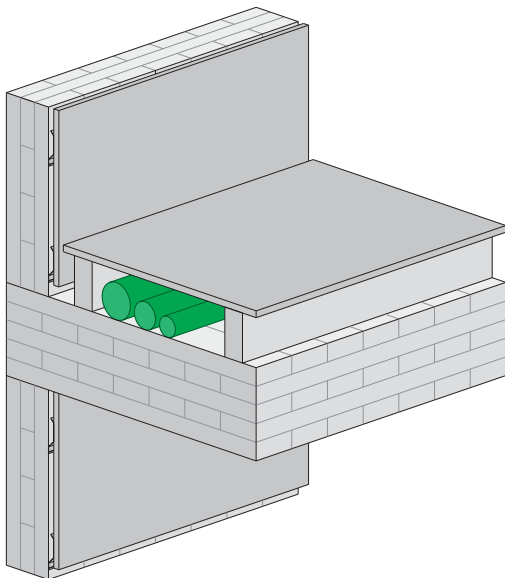

Mechanical, Electrical, and Plumbing

Horizontal, Suspended Ceiling

NS-DS2505

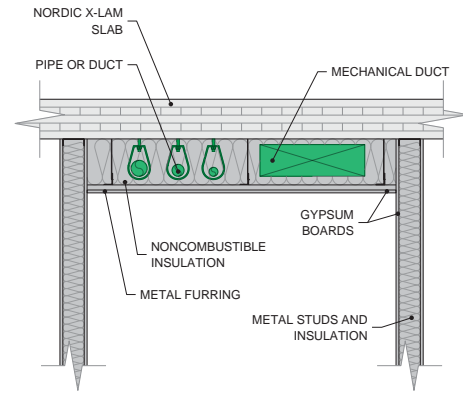
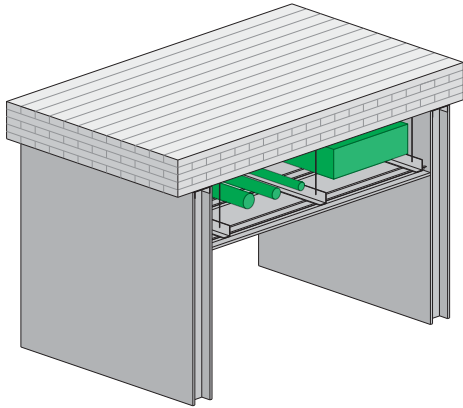

Mechanical, Electrical, and Plumbing

Horizontal, Bevelled Beam

NS-DS2507

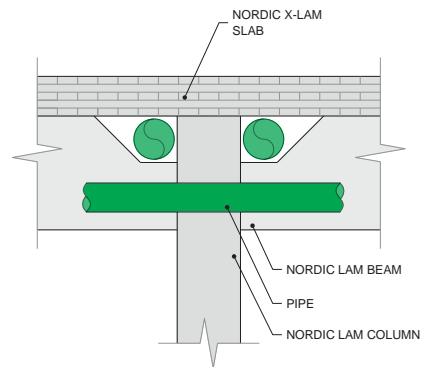
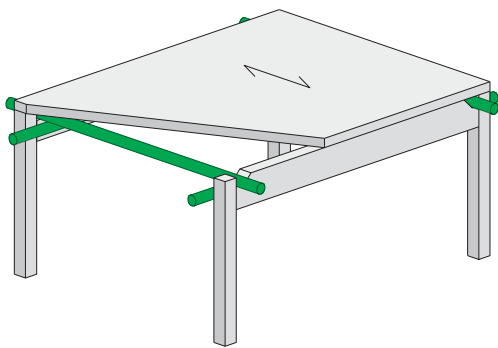

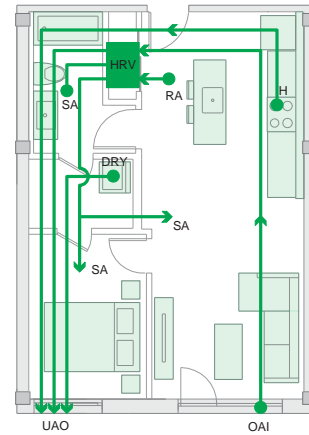
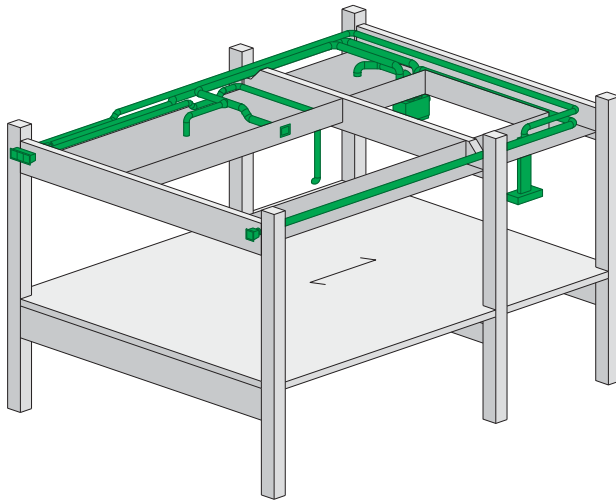

- Legend**
- SA Supply Air
 - H Hood
 - OAI Outdoor Air Intake
 - RA Return Air
 - UAO Used Air Outlet
 - SEC Dryer
 - HRV Heat Recovery Ventilator

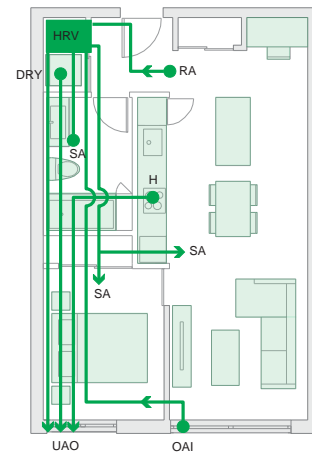
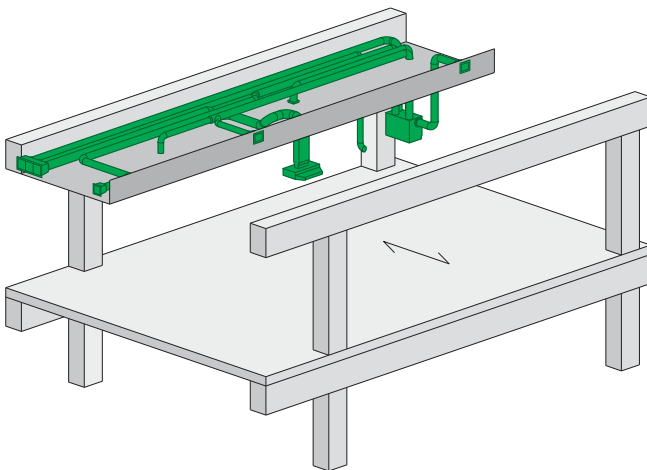

- Legend**
- SA Supply Air
 - H Hood
 - OAI Outdoor Air Intake
 - RA Return Air
 - UAO Used Air Outlet
 - SEC Dryer
 - HRV Heat Recovery Ventilator

NORDIC

TECHNICAL GUIDE
NORDIC X-LAM

NS-GT6 

ENGLISH
VERSION
2026-02-01

ARCHITECTURAL
DETAILS

4

GENERAL NOTES

1.0 General

- 1.1 This document supersedes all previous versions. For the latest version, consult nordic.ca or contact Nordic Structures.
- 1.2 The information contained in this document is provided for information purposes only. This information should not be used for any application without examination and verification of its accuracy, suitability and applicability by a licensed engineer, architect or other professional. Nordic Structures does not guarantee that the information is suitable for any general or particular use, and assumes no responsibility for the use, application of and/or reference to the information.
- 1.3 Certain commercial products are identified in this document in order to properly represent the test procedure. In no case does such identification imply recommendations or endorsement by Nordic Structures, nor does it imply that the product or material identified is the best available for the purpose.
- 1.4 For more information, consult nordic.ca or contact Nordic Structures.

2.0 Fire Safety

- 2.1 The fire resistance rating (FRR) is determined using the design methodology specified in Annex B of CSA O86-14, Engineering design in wood. The fire resistance rating may also be determined on the basis of the results of tests conducted in conformance with CAN/ULC-S101, Fire Endurance Tests of Building Construction and Materials.
- 2.2 To determine the fire resistance of an element or assembly according to other assumptions than those specified in this document, consult the Nordic X-Lam technical guide or use Nordic Sizer software.
- 2.3 The fire performance criteria for evaluating the separating function of building elements shall be considered when required by the applicable building code.

2.4 For this purpose, among other requirements, many firestop systems suitable for mass timber are available. For more details, consult the product suppliers.

2.5 Additional references: Fire-Resistance-Tested Mass Timber Assemblies and Penetrations.

3.0 Envelope

- 3.1 Good thermal insulation is never arbitrary and must always be chosen according to location, area and climate.
- 3.2 The total thermal resistance of an assembly is calculated according to the values of thermal conductivity, λ , and thermal resistance, RSI, indicated in the following table.
- 3.3 To convert the thermal resistance of the International System (RSI) [$\text{m}^2\text{K}/\text{W}$] to the R-value [$\text{ft}^2\text{Fh}/\text{BTU}$], divide the RSI value by 0.1761.
- 3.4 As stated in technical note NS-NT602-CA-en, Nordic X-Lam cross-laminated timber acts as a vapor barrier.
- 3.5 The use of closed cell spray polyurethane is not recommended for exterior wall assemblies made of cross-laminated timber because of its low permeability.
- 3.6 The study of the building envelope, including the control of condensation, the transfers of heat, air, moisture and sound, as well as the details of joining and fixing of the coverings, shall be carried out in accordance with the applicable building code.

GENERAL NOTES (CONTINUED)

Thermal Resistance of Materials

Product	t (mm)	λ (W/mK)	RSI (m ² K/W)
Nordic Lam	25	0.13	0.19
Nordic X-Lam	25	0.13	0.19
Sawn lumber	25	0.12	0.21
Spray polyurethane (BASF)	50	0.02	2.50
Stone wool (Rockwool ComfortBatt R24)	139.7	0.033	4.23
Gypsum board	12.7	0.159	0.08
Polyisocyanurate (SOPRA-ISO)	-	0.025	-
Air cavity – Wall	13-20	-	0.16
Air cavity – Ceiling	13-40 40-90	-	0.15 0.16
Interior air film – Wall	-	-	0.12
Interior air film – Ceiling	-	-	0.11
Exterior air film	-	-	0.03

References: Test Report AT-00205 (AIR-INS inc.), Wood Handbook (FPL, 2010), Evaluation Listing CCMC 13588-L (2011), Technical Data Sheet (Rockwool, 2017), Technical Data Sheet 190304SCANE (Soprema, 2019) and Table A-9.36.2.4.1.1)-D of NBC 2015.

4.0 Acoustics

- 4.1 The Sound Transmission Class (STC) rating describes the performance of the separating wall or floor/ceiling assembly, whereas the Apparent Sound Transmission Class (ASTC) takes into consideration the performance of the separating element as well as the flanking transmission paths. Moreover, building professionals should ensure that floors are designed to minimize impact transmission. For more details, see Appendix Note A-9.11. of the NBC 2015.
- 4.2 The following pages present separating assemblies that may comply with the applicable building code. However, selecting an appropriate separating assembly is only one part of the solution for reducing airborne sound transmission between adjoining spaces: to fully address the sound performance of the whole system, flanking assemblies must be connected to the separating assembly. For more details, see Appendix Note A-9.11.1.4. of the NBC 2015.
- 4.3 Unless otherwise noted, concrete topping and prefabricated concrete topping used in assemblies have a density of 2 710 kg/m³.
- 4.4 The use of prefabricated concrete topping in floor assemblies is only required by the acoustical testing procedure.
- 4.5 The use of an acoustic membrane under a floor covering is recommended, especially when it is a hard surface coating (e.g. ceramic).
- 4.6 Unless otherwise noted, the acoustic performance values are derived from test results from a certified laboratory. Test reports are available upon request.
- 4.7 Additional references:
 - [WoodWorks – Acoustics and Mass Timber: Room-to-Room Noise Control](#)
 - [WoodWorks – Acoustically-Tested Mass Timber Assemblies](#)
 - [University of Oregon – Acoustic Lab Testing of Typical Multi-Family Residential Wall and Floor Assemblies](#)

Architecture, Assembly

Exterior Wall

NS-DA2000

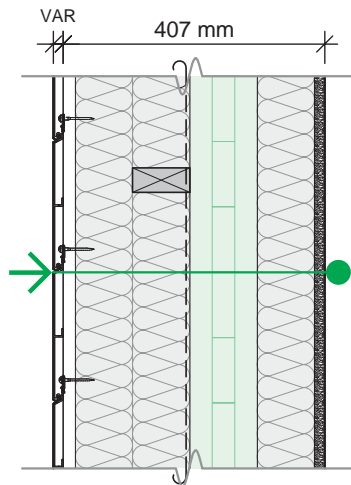

E1

Fire-resistance rating	FRR ^(a)	1 h
Thermal resistance	RSI / R	6.7 / 38
Acoustic ratings	STC / ASTC	n.a. / n.a.
	IIC / AIC	n.a. / n.a.

a) The fire-resistance rating is based on an effective length of 3 m and on a concentric specified uniform load of 300 kN/m.

- CLADDING (UP TO THE DESIGNER)
- AIR GAP 19 mm
- WOOD STUDS 38 mm X 89 mm @ 610 mm O.C.
- WOOD FURRING 38 mm X 89 mm @ 610 mm O.C.
- 2 ROWS OF STONE WOOL INSULATION 89 mm EA.
- AIR BARRIER MEMBRANE
- NORDIC X-LAM 105 mm
- WOOD STUDS 38 mm X 89 mm @ 610 mm O.C.
- 1 ROW OF STONE WOOL INSULATION 89 mm
- 1 TYPE X GYPSUM BOARD 15.9 mm

Architecture, Assembly

Exterior Wall

NS-DA2001

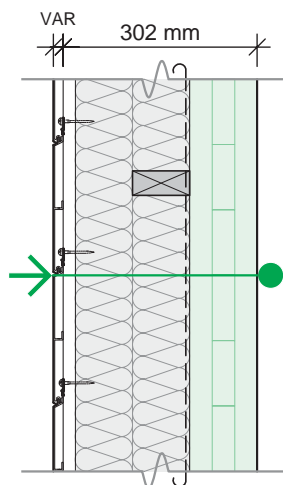

E2

Fire-resistance rating	FRR ^(a)	30 min
Thermal resistance	RSI / R	4.8 / 27
Acoustic ratings	STC / ASTC	n.a. / n.a.
	IIC / AIC	n.a. / n.a.

a) The fire-resistance rating is based on an effective length of 3 m and on a concentric specified uniform load of 300 kN/m.

- CLADDING (UP TO THE DESIGNER)
- AIR GAP 19 mm
- WOOD STUDS 38 mm X 89 mm @ 610 mm O.C.
- WOOD FURRING 38 mm X 89 mm @ 610 mm O.C.
- 2 ROWS OF STONE WOOL INSULATION 89 mm EA.
- AIR BARRIER MEMBRANE
- NORDIC X-LAM 105 mm

Architecture, Assembly

Exterior Wall

NS-DA2002

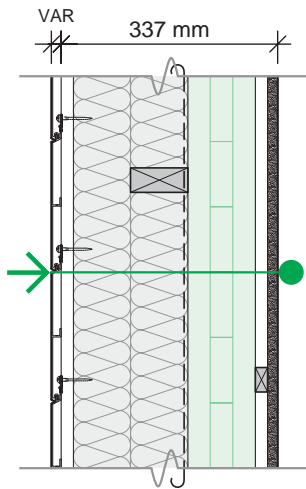

E3

Fire-resistance rating	FRR ^(a)	1 h
Thermal resistance	RSI / R	5.0 / 28
Acoustic ratings	STC / ASTC	n.a. / n.a.
	IIC / AIC	n.a. / n.a.

a) The fire-resistance rating is based on an effective length of 3 m and on a concentric specified uniform load of 300 kN/m.

- CLADDING (UP TO THE DESIGNER)
- AIR GAP 19 mm
- WOOD STUDS 38 mm X 89 mm @ 610 mm O.C.
- WOOD FURRING 38 mm X 89 mm @ 610 mm O.C.
- 2 ROWS OF STONE WOOL INSULATION 89 mm EA.
- AIR BARRIER MEMBRANE
- NORDIC X-LAM 105 mm
- WOOD FURRING 19 mm @ 610 mm O.C.
- 1 TYPE X GYPSUM BOARD 15.9 mm

Architecture, Assembly

Exterior Wall

NS-DA2003

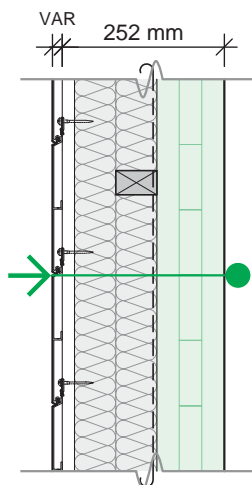

E4

Fire-resistance rating	FRR ^(a)	30 min
Thermal resistance	RSI / R	3.7 / 21
Acoustic ratings	STC / ASTC	n.a. / n.a.
	IIC / AIC	n.a. / n.a.

a) The fire-resistance rating is based on an effective length of 3 m and on a concentric specified uniform load of 300 kN/m.

- CLADDING (UP TO THE DESIGNER)
- AIR GAP 19 mm
- WOOD STUDS 38 mm X 64 mm @ 610 mm O.C.
- WOOD FURRING 38 mm X 64 mm @ 610 mm O.C.
- 2 ROWS OF STONE WOOL INSULATION 64 mm EA.
- AIR BARRIER MEMBRANE
- NORDIC X-LAM 105 mm

Architecture, Assembly

Exterior Wall

NS-DA2004

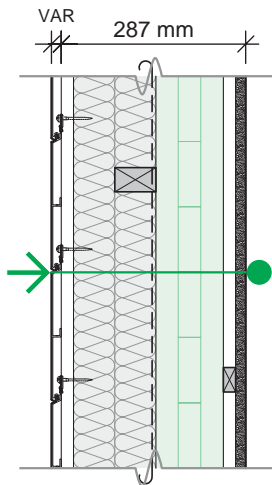

E5

Fire-resistance rating	FRR ^(a)	1 h
Thermal resistance	RSI / R	4.0 / 22
Acoustic ratings	STC / ASTC	n.a. / n.a.
	IIC / AIC	n.a. / n.a.

a) The fire-resistance rating is based on an effective length of 3 m and on a concentric specified uniform load of 300 kN/m.

- CLADDING (UP TO THE DESIGNER)
- AIR GAP 19 mm
- WOOD STUDS 38 mm X 64 mm @ 610 mm O.C.
- WOOD FURRING 38 mm X 64 mm @ 610 mm O.C.
- 2 ROWS OF STONE WOOL INSULATION 64 mm EA.
- AIR BARRIER MEMBRANE
- NORDIC X-LAM 105 mm
- WOOD FURRING 19 mm @ 610 mm O.C.
- 1 TYPE X GYPSUM BOARD 15.9 mm

Architecture, Assembly

Exterior Wall

NS-DA2005

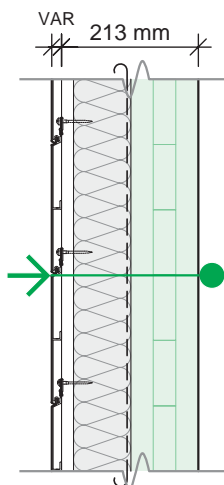

E6

Fire-resistance rating	FRR ^(a)	30 min
Thermal resistance	RSI / R	2.9 / 16
Acoustic ratings	STC / ASTC	n.a. / n.a.
	IIC / AIC	n.a. / n.a.

a) The fire-resistance rating is based on an effective length of 3 m and on a concentric specified uniform load of 300 kN/m.

- CLADDING (UP TO THE DESIGNER)
- AIR GAP 19 mm
- WOOD STUDS 38 mm X 89 mm @ 610 mm O.C.
- 1 ROW OF STONE WOOL INSULATION 89 mm
- AIR BARRIER MEMBRANE
- NORDIC X-LAM 105 mm

Architecture, Assembly

Exterior Wall

NS-DA2006

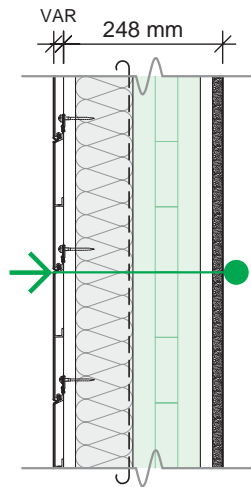

E7

Fire-resistance rating	FRR ^(a)	1 h
Thermal resistance	RSI / R	3.1 / 18
Acoustic ratings	STC / ASTC	n.a. / n.a.
	IIC / AIIIC	n.a. / n.a.

a) The fire-resistance rating is based on an effective length of 3 m and on a concentric specified uniform load of 300 kN/m.

- CLADDING (UP TO THE DESIGNER)
- AIR GAP 19 mm
- WOOD STUDS 38 mm X 89 mm @ 610 mm O.C.
- 1 ROW OF STONE WOOL INSULATION 89 mm
- AIR BARRIER MEMBRANE
- NORDIC X-LAM 105 mm
- WOOD FURRING 19 mm @ 610 mm O.C.
- 1 TYPE X GYPSUM BOARD 15.9 mm

Architecture, Assembly

Exterior Wall

NS-DA2007

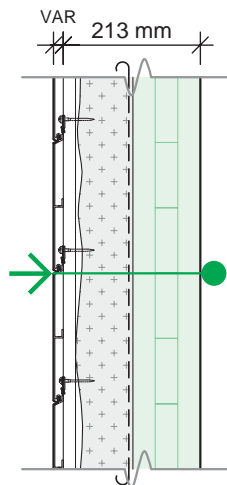

E8

Fire-resistance rating	FRR ^(a)	30 min
Thermal resistance	RSI / R	3.4 / 20
Acoustic ratings	STC / ASTC	n.a. / n.a.
	IIC / AIIIC	n.a. / n.a.

a) The fire-resistance rating is based on an effective length of 3 m and on a concentric specified uniform load of 300 kN/m.

- CLADDING (UP TO THE DESIGNER)
- AIR GAP 19 mm
- WOOD STUDS 38 mm X 89 mm @ 610 mm O.C.
- SPRAYED POLYURETHANE FOAM 89 mm
- AIR BARRIER MEMBRANE
- NORDIC X-LAM 105 mm

Architecture, Assembly

Exterior Wall

NS-DA2008

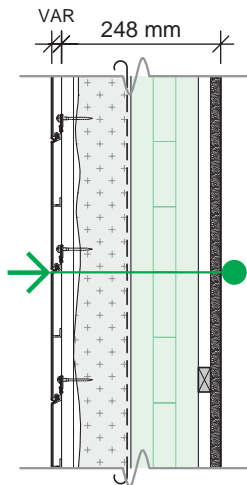

E9

Fire-resistance rating	FRR ^(a)	1 h
Thermal resistance	RSI / R	3.7 / 21
Acoustic ratings	STC / ASTC	n.a. / n.a.
	IIC / AIC	n.a. / n.a.

a) The fire-resistance rating is based on an effective length of 3 m and on a concentric specified uniform load of 300 kN/m.

- CLADDING (UP TO THE DESIGNER)
- AIR GAP 19 mm
- WOOD STUDS 38 mm X 89 mm @ 610 mm O.C.
- SPRAYED POLYURETHANE FOAM 89 mm
- AIR BARRIER MEMBRANE
- NORDIC X-LAM 105 mm
- WOOD FURRING 19 mm @ 610 mm O.C.
- 1 TYPE X GYPSUM BOARD 15.9 mm

Architecture, Assembly

Exterior Wall

NS-DA2009

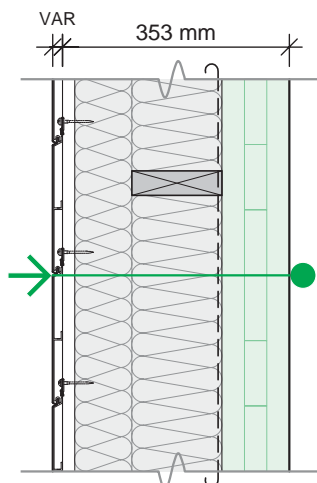

E10

Fire-resistance rating	FRR ^(a)	30 min
Thermal resistance	RSI / R	5.8 / 33
Acoustic ratings	STC / ASTC	n.a. / n.a.
	IIC / AIC	n.a. / n.a.

a) The fire-resistance rating is based on an effective length of 3 m and on a concentric specified uniform load of 300 kN/m.

- CLADDING (UP TO THE DESIGNER)
- AIR GAP 19 mm
- WOOD STUDS 38 mm X 89 mm @ 610 mm O.C.
- WOOD FURRING 38 mm X 140 mm @ 610 mm O.C.
- 1 ROW OF STONE WOOL INSULATION 89 mm
- 1 ROW OF STONE WOOL INSULATION 140 mm
- AIR BARRIER MEMBRANE
- NORDIC X-LAM 105 mm

Architecture, Assembly

Exterior Wall

NS-DA2010

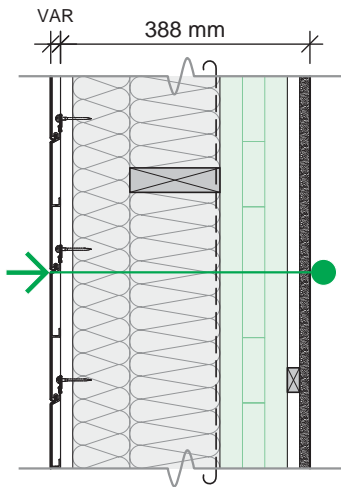

E11

Fire-resistance rating	FRR ^(a)	1 h
Thermal resistance	RSI / R	6.1 / 35
Acoustic ratings	STC / ASTC	n.a. / n.a.
	IIC / AIIIC	n.a. / n.a.

a) The fire-resistance rating is based on an effective length of 3 m and on a concentric specified uniform load of 300 kN/m.

- CLADDING (UP TO THE DESIGNER)
- AIR GAP 19 mm
- WOOD STUDS 38 mm X 89 mm @ 610 mm O.C.
- WOOD FURRING 38 mm X 140 mm @ 610 mm O.C.
- 1 ROW OF STONE WOOL INSULATION 89 mm
- 1 ROW OF STONE WOOL INSULATION 140 mm
- AIR BARRIER MEMBRANE
- NORDIC X-LAM 105 mm
- WOOD FURRING 19 mm @ 610 mm O.C.
- 1 TYPE X GYPSUM BOARD 15.9 mm

Architecture, Assembly

Partition

NS-DA2100

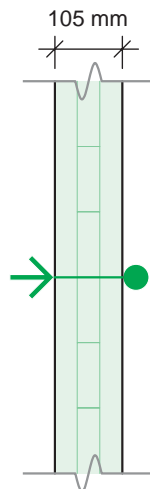

P1

Fire-resistance rating	FRR ^(a)	30 min / 30 min
Thermal resistance	RSI / R	n.a. / n.a.
Acoustic ratings	STC ^(b) / ASTC	33 / n.a.
	IIC / AIIIC	n.a. / n.a.

a) The fire-resistance ratings on each side of the partition are based on an effective length of 3 m and on a concentric specified uniform load of 300 kN/m.

b) Composition and acoustic performance taken from the CLT Handbook – Canadian Edition (FPInnovations, 2011). Acoustic performance based on a CLT thickness of 95-115 mm.

- NORDIC X-LAM 105 mm

Architecture, Assembly

Partition

NS-DA2101

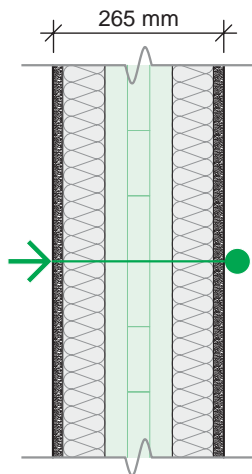

P2

Fire-resistance rating	FRR ^(a)	1 h / 1 h
------------------------	--------------------	-----------

Thermal resistance	RSI / R	n.a. / n.a.
--------------------	---------	-------------

	STC ^(b) / ASTC	58 / n.a.
--	---------------------------	-----------

Acoustic ratings	IIC / AIC	n.a. / n.a.
------------------	-----------	-------------

a) The fire-resistance ratings on each side of the partition are based on an effective length of 3 m and on a concentric specified uniform load of 300 kN/m.

b) Composition and acoustic performance taken from the CLT Handbook – Canadian Edition (FPIInnovations, 2011). Acoustic performance based on a CLT thickness of 95-115 mm.

- 1 TYPE X GYPSUM BOARD 15.9 mm
- 1 ROW OF MINERAL WOOL INSULATION 64 mm
- WOOD STUDS 38 mm X 64 mm @ 610 mm O.C.
- NORDIC X-LAM 105 mm
- WOOD STUDS 38 mm X 64 mm @ 610 mm O.C. OFF-CENTERED FROM THE OTHER ROW OF WOOD STUDS
- 1 ROW OF MINERAL WOOL INSULATION 64 mm
- 1 TYPE X GYPSUM BOARD 15.9 mm

Architecture, Assembly

Partition

NS-DA2102

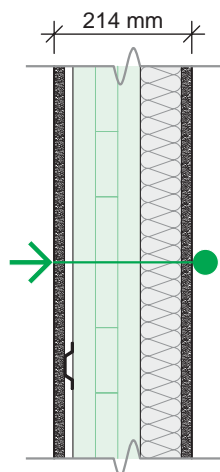

P3

Fire-resistance rating	FRR ^(a)	1 h / 1 h
------------------------	--------------------	-----------

Thermal resistance	RSI / R	n.a. / n.a.
--------------------	---------	-------------

	STC / ASTC	53 / n.a.
--	------------	-----------

Acoustic ratings	IIC / AIC	n.a. / n.a.
------------------	-----------	-------------

a) The fire-resistance ratings on each side of the partition are based on an effective length of 3 m and on a concentric specified uniform load of 300 kN/m.

- 1 TYPE X GYPSUM BOARD 15.9 mm
- RESILIENT CHANNELS 12.7 mm @ 406 mm O.C. INSTALLED HORIZONTALLY
- NORDIC X-LAM 105 mm
- WOOD STUDS 38 mm X 64 mm @ 610 mm O.C.
- 1 ROW OF MINERAL WOOL INSULATION 64 mm
- 1 TYPE X GYPSUM BOARD 15.9 mm

Architecture, Assembly

Partition

NS-DA2103

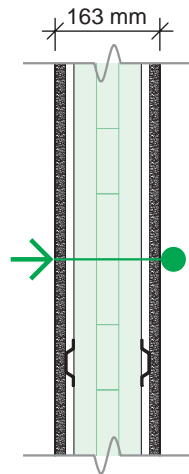

P4

Fire-resistance rating	FRR ^(a)	1 h / 1 h
Thermal resistance	RSI / R	n.a. / n.a.
Acoustic ratings	STC ^(b) / ASTC	37 / n.a.
	IIC / AIIIC	n.a. / n.a.

a) The fire-resistance ratings on each side of the partition are based on an effective length of 3 m and on a concentric specified uniform load of 300 kN/m.

b) Composition and acoustic performance taken from the CLT Handbook – Canadian Edition (FPInnovations, 2011). Acoustic performance based on a CLT thickness of 95-115 mm.

- 1 TYPE X GYPSUM BOARD 15.9 mm
- RESILIENT CHANNELS 12.7 mm @ 406 mm O.C. INSTALLED HORIZONTALLY
- NORDIC X-LAM 105 mm
- RESILIENT CHANNELS 12.7 mm @ 406 mm O.C. INSTALLED HORIZONTALLY
- 1 TYPE X GYPSUM BOARD 15.9 mm

Architecture, Assembly

Partition

NS-DA2104

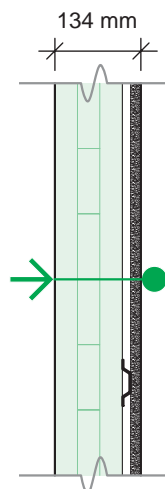

P5

Fire-resistance rating	FRR ^(a)	30 min / 1 h
Thermal resistance	RSI / R	n.a. / n.a.
Acoustic ratings	STC ^(b) / ASTC	37 / n.a.
	IIC / AIIIC	n.a. / n.a.

a) The fire-resistance ratings on each side of the partition are based on an effective length of 3 m and on a concentric specified uniform load of 300 kN/m.

b) Composition and acoustic performance taken from the CLT Handbook – Canadian Edition (FPInnovations, 2011). Acoustic performance based on a CLT thickness of 95-115 mm.

- NORDIC X-LAM 105 mm
- RESILIENT CHANNELS 12.7 mm @ 406 mm O.C. INSTALLED HORIZONTALLY
- 1 TYPE X GYPSUM BOARD 15.9 mm

Architecture, Assembly

Partition

NS-DA2105

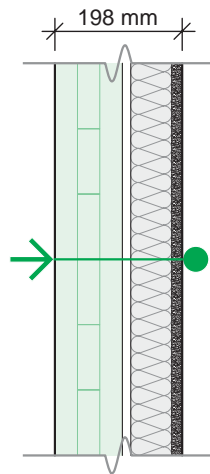

P6

Fire-resistance rating	FRR ^(a)	30 min / 1 h
Thermal resistance	RSI / R	n.a. / n.a.
Acoustic ratings	STC / ASTC	n.a. / 47
	IIC / AIC	n.a. / n.a.

a) The fire-resistance ratings on each side of the partition are based on an effective length of 3 m and on a concentric specified uniform load of 300 kN/m.

- NORDIC X-LAM 105 mm
- AIR GAP 12.7 mm
- WOOD STUDS 38 mm X 64 mm @ 406 mm O.C.
- 1 ROW OF MINERAL WOOL INSULATION 64 mm
- 1 TYPE X GYPSUM BOARD 15.9 mm

Architecture, Assembly

Partition

NS-DA2106

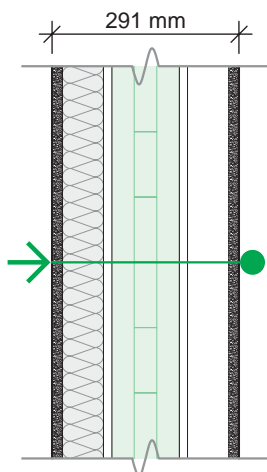

P7

Fire-resistance rating	FRR ^(a)	1 h / 1 h
Thermal resistance	RSI / R	n.a. / n.a.
Acoustic ratings	STC / ASTC	n.a. / 50
	IIC / AIC	n.a. / n.a.

a) The fire-resistance ratings on each side of the partition are based on an effective length of 3 m and on a concentric specified uniform load of 300 kN/m.

- 1 TYPE X GYPSUM BOARD 15.9 mm
- 1 ROW OF MINERAL WOOL INSULATION 64 mm
- WOOD STUDS 38 mm X 64 mm @ 406 mm O.C.
- AIR GAP 12.7 mm
- NORDIC X-LAM 105 mm
- AIR GAP 12.7 mm
- WOOD STUDS 38 mm X 64 mm @ 406 mm O.C.
- 1 TYPE X GYPSUM BOARD 15.9 mm

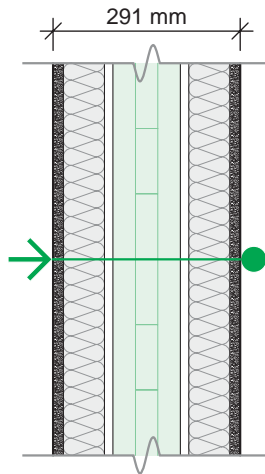

P8

Fire-resistance rating	FRR ^(a)	1 h / 1 h
Thermal resistance	RSI / R	n.a. / n.a.
Acoustic ratings	STC / ASTC	n.a. / 54
	IIC / AIIIC	n.a. / n.a.

a) The fire-resistance ratings on each side of the partition are based on an effective length of 3 m and on a concentric specified uniform load of 300 kN/m.

- 1 TYPE X GYPSUM BOARD 15.9 mm
- 1 ROW OF MINERAL WOOL INSULATION 64 mm
- WOOD STUDS 38 mm X 64 mm @ 406 mm O.C.
- AIR GAP 12.7 mm
- NORDIC X-LAM 105 mm
- AIR GAP 12.7 mm
- WOOD STUDS 38 mm X 64 mm @ 406 mm O.C.
- 1 ROW OF MINERAL WOOL INSULATION 64 mm
- 1 TYPE X GYPSUM BOARD 15.9 mm

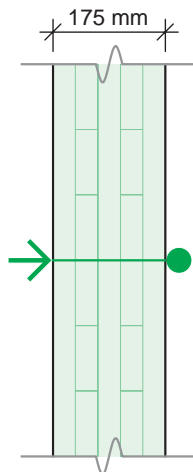

P9

Fire-resistance rating	FRR ^(a)	1.5 h / 1.5 h
Thermal resistance	RSI / R	n.a. / n.a.
Acoustic ratings	STC / ASTC	37 / n.a.
	IIC / AIIIC	n.a. / n.a.

a) The fire-resistance ratings on each side of the partition are based on an effective length of 3 m and on a concentric specified uniform load of 800 kN/m.

- NORDIC X-LAM 175 mm

Architecture, Assembly

Partition

NS-DA2109

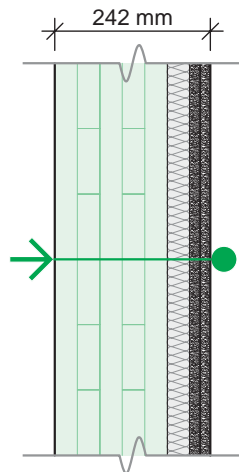

P10

Fire-resistance rating	FRR ^(a)	1.5 h / 2.5 h
Thermal resistance	RSI / R	n.a. / n.a.
Acoustic ratings	STC / ASTC	53 / n.a.
	IIC / AIC	n.a. / n.a.

a) The fire-resistance ratings on each side of the partition are based on an effective length of 3 m and on a concentric specified uniform load of 800 kN/m.

- NORDIC X-LAM 175 mm
- Z-CHANNELS (26 GAUGE) 35 mm @ 406 mm O.C.
INSTALLED VERTICALLY
- 1 ROW OF FIBREGLASS INSULATION OF TYPE
"ROSE FIBERGLAS ECOTOUCH" 38 mm
- 2 TYPE X GYPSUM BOARDS 15.9 mm EA.

Architecture, Assembly

Partition

NS-DA2110

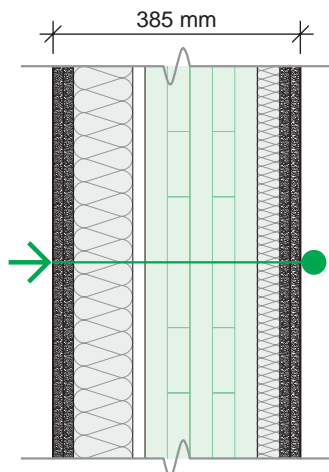

P11

Fire-resistance rating	FRR ^(a)	2.5 h / 2.5 h
Thermal resistance	RSI / R	n.a. / n.a.
Acoustic ratings	STC / ASTC	71 / n.a.
	IIC / AIC	n.a. / n.a.

a) The fire-resistance ratings on each side of the partition are based on an effective length of 3 m and on a concentric specified uniform load of 800 kN/m.

- 2 TYPE X GYPSUM BOARDS 15.9 mm EA.
- METAL STUDS (26 GAUGE) 31 mm X 92 mm @ 406 mm O.C.
- 1 ROW OF FIBREGLASS INSULATION OF TYPE
"ROSE FIBERGLAS ECOTOUCH" 92 mm
- AIR GAP 19 mm
- NORDIC X-LAM 175 mm
- Z-CHANNELS (26 GAUGE) 35 mm @ 406 mm O.C.
INSTALLED VERTICALLY
- 1 ROW OF FIBREGLASS INSULATION OF TYPE
"ROSE FIBERGLAS ECOTOUCH" 38 mm
- 2 TYPE X GYPSUM BOARDS 15.9 mm EA.

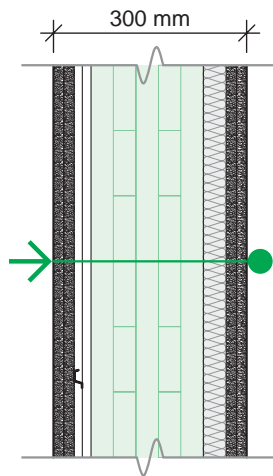

P12

Fire-resistance rating	FRR ^(a)	2.5 h / 2.5 h
Thermal resistance	RSI / R	n.a. / n.a.
Acoustic ratings	STC / ASTC	53 / n.a.
	IIC / AIIIC	n.a. / n.a.

a) The fire-resistance ratings on each side of the partition are based on an effective length of 3 m and on a concentric specified uniform load of 800 kN/m.

- 2 TYPE X GYPSUM BOARDS 15.9 mm EA.
- RESILIENT CHANNELS 12.7 mm @ 406 mm O.C. INSTALLED HORIZONTALLY
- PLYWOOD STRIPS 12.7 mm @ 406 mm O.C.
- NORDIC X-LAM 175 mm
- Z-CHANNELS (26 GAUGE) 35 mm @ 406 mm O.C. INSTALLED VERTICALLY
- 1 ROW OF FIBREGLASS INSULATION OF TYPE "ROSE FIBERGLAS ECOTOUCH" 38 mm
- 2 TYPE X GYPSUM BOARDS 15.9 mm EA.

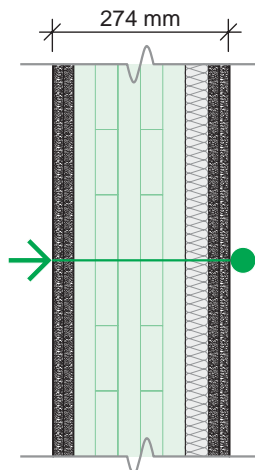

P13

Fire-resistance rating	FRR ^(a)	2.5 h / 2.5 h
Thermal resistance	RSI / R	n.a. / n.a.
Acoustic ratings	STC / ASTC	53 / n.a.
	IIC / AIIIC	n.a. / n.a.

a) The fire-resistance ratings on each side of the partition are based on an effective length of 3 m and on a concentric specified uniform load of 800 kN/m.

- 2 TYPE X GYPSUM BOARDS 15.9 mm EA.
- NORDIC X-LAM 175 mm
- Z-CHANNELS (26 GAUGE) 35 mm @ 406 mm O.C. INSTALLED VERTICALLY
- 1 ROW OF FIBREGLASS INSULATION OF TYPE "ROSE FIBERGLAS ECOTOUCH" 38 mm
- 2 TYPE X GYPSUM BOARDS 15.9 mm EA.

Architecture, Assembly

Partition

NS-DA2113

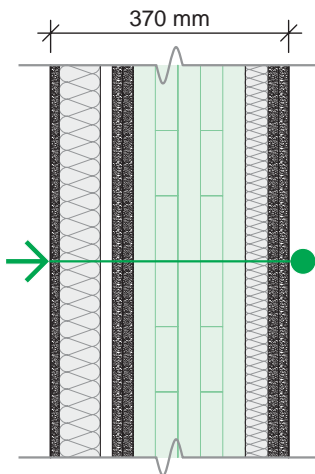

P14

Fire-resistance rating	FRR ^(a)	2.5 h / 2.5 h
------------------------	--------------------	---------------

Thermal resistance	RSI / R	n.a. / n.a.
--------------------	---------	-------------

Acoustic ratings	STC / ASTC	65 / n.a.
	IIC / AIC	n.a. / n.a.

a) The fire-resistance ratings on each side of the partition are based on an effective length of 3 m and on a concentric specified uniform load of 800 kN/m.

- 1 TYPE C GYPSUM BOARD 12.7 mm
- METAL STUDS (26 GAUGE) 31 mm X 64 mm @ 406 mm O.C.
- 1 ROW OF STONE WOOL INSULATION OF TYPE "ROXUL AFB" 64 mm
- AIR GAP 19 mm
- 2 TYPE X GYPSUM BOARDS 15.9 mm EA.
- NORDIC X-LAM 175 mm
- Z-CHANNELS (26 GAUGE) 35 mm @ 406 mm O.C.
INSTALLED VERTICALLY
- 1 ROW OF FIBREGLASS INSULATION OF TYPE "ROSE FIBERGLAS ECOTOUCH" 38 mm
- 2 TYPE X GYPSUM BOARDS 15.9 mm EA.

Architecture, Assembly

Partition

NS-DA2114

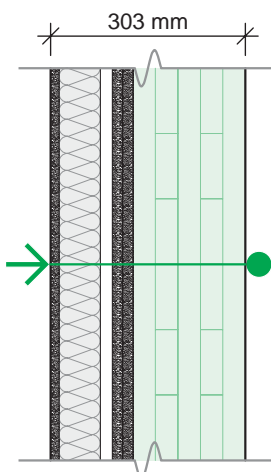

P15

Fire-resistance rating	FRR ^(a)	2.5 h / 1.5 h
------------------------	--------------------	---------------

Thermal resistance	RSI / R	n.a. / n.a.
--------------------	---------	-------------

Acoustic ratings	STC / ASTC	62 / n.a.
	IIC / AIC	n.a. / n.a.

a) The fire-resistance ratings on each side of the partition are based on an effective length of 3 m and on a concentric specified uniform load of 800 kN/m.

- 1 TYPE C GYPSUM BOARD 12.7 mm
- METAL STUDS (26 GAUGE) 31 mm X 64 mm @ 406 mm O.C.
- 1 ROW OF STONE WOOL INSULATION OF TYPE "ROXUL AFB" 64 mm
- AIR GAP 19 mm
- 2 TYPE X GYPSUM BOARDS 15.9 mm EA.
- NORDIC X-LAM 175 mm

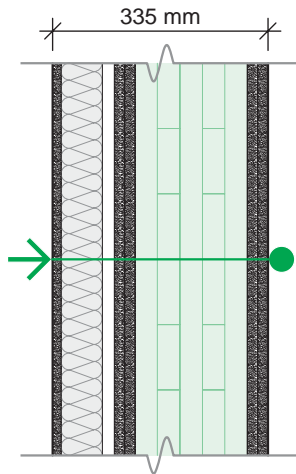

P16

Fire-resistance rating	FRR ^(a)	2.5 h / 2.5 h
Thermal resistance	RSI / R	n.a. / n.a.
Acoustic ratings	STC / ASTC	61 / n.a.
	IIC / AIIIC	n.a. / n.a.

a) The fire-resistance ratings on each side of the partition are based on an effective length of 3 m and on a concentric specified uniform load of 800 kN/m.

- 1 TYPE C GYPSUM BOARD 12.7 mm
- METAL STUDS (26 GAUGE) 31 mm X 64 mm @ 406 mm O.C.
- 1 ROW OF STONE WOOL INSULATION OF TYPE "ROXUL AFB" 64 mm
- AIR GAP 19 mm
- 2 TYPE X GYPSUM BOARDS 15.9 mm EA.
- NORDIC X-LAM 175 mm
- 2 TYPE X GYPSUM BOARDS 15.9 mm EA.

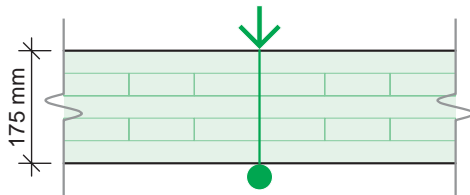

F1

Fire-resistance rating	FRR ^(a)	1.5 h
Thermal resistance	RSI / R	n.a. / n.a.
Acoustic ratings	STC / ASTC	39 / n.a.
	IIC / AIIIC	27 / n.a.

a) The fire-resistance rating is based on a span of 5.75 m and on a specified uniform load of 4.75 kPa.

- NORDIC X-LAM 175 mm

Architecture, Assembly

Floor

NS-DA2201

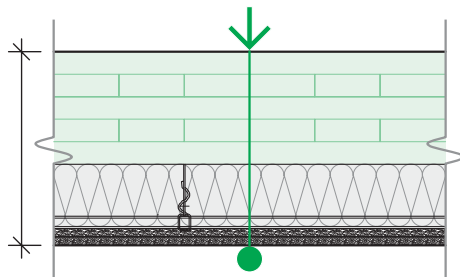

F2

Fire-resistance rating	FRR ^(a)	2.5 h
Thermal resistance	RSI / R	n.a. / n.a.
	STC ^(b) / ASTC	64 / n.a.
Acoustic ratings	IIC ^(b) / AIC	59 / n.a.

- a) The fire-resistance rating is based on a span of 5.75 m and on a specified uniform load of 4.75 kPa.
- b) Composition and acoustic performance taken from the CLT Handbook – Canadian Edition (FPInnovations, 2011). Acoustic performance based on a CLT thickness of 146 mm.

- NORDIC X-LAM 175 mm
- SUSPENDED CEILING:
 - RESILIENT METALLIC HANGERS 100 mm
 - METAL TRACKS @ 406 mm O.C. MIN
 - SOUNDPROOFING MATERIAL 100 mm
- 2 TYPE X GYPSUM BOARDS 12.7 mm EA.

Architecture, Assembly

Floor

NS-DA2202

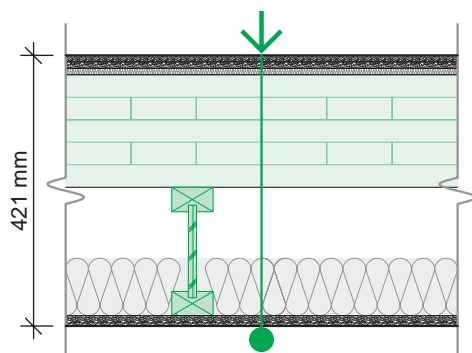

F3

Fire-resistance rating	FRR ^(a)	2 h
Thermal resistance	RSI / R	n.a. / n.a.
	STC / ASTC	n.a. / n.a.
Acoustic ratings	IIC / AIC	n.a. / n.a.

- a) The fire-resistance rating is based on a span of 5.75 m and on a specified uniform load of 4.75 kPa.

- UNDERLAY OF TYPE "FERMACELL 2E32" 30 mm OR "PERMABASE" WITH "SONOPAN"
- NORDIC X-LAM 175 mm
- NORDIC JOIST 200 mm @ 610 mm O.C.
- SOUNDPROOFING MATERIAL 89 mm
- 1 TYPE X GYPSUM BOARD 15.9 mm

Architecture, Assembly

Floor

NS-DA2203

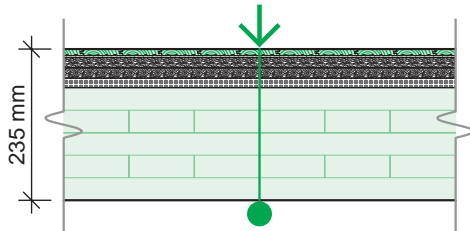

F4

Fire-resistance rating	FRR ^(a)	1.5 h
Thermal resistance	RSI / R	n.a. / n.a.
Acoustic ratings	STC / ASTC	n.a. / 47
	IIC / AIIIC	n.a. / 46

a) The fire-resistance rating is based on a span of 5.75 m and on a specified uniform load of 4.75 kPa.

- FLOATING FLOOR 10 mm
- UNDERLAY OF TYPE "INSONOBOIS" 3 mm
- 2 UNDERLAYS OF TYPE "FIBEROCK" 15.9 mm EA.
- UNDERLAY OF TYPE "INSONOMAT" 15 mm
- NORDIC X-LAM 175 mm

Architecture, Assembly

Floor

NS-DA2204

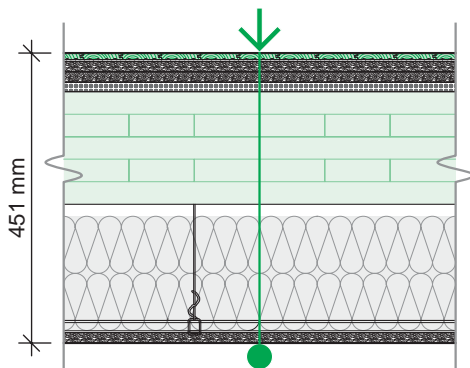

F5

Fire-resistance rating	FRR ^(a)	2 h
Thermal resistance	RSI / R	n.a. / n.a.
Acoustic ratings	STC / ASTC	n.a. / 59
	IIC / AIIIC	n.a. / 61

a) The fire-resistance rating is based on a span of 5.75 m and on a specified uniform load of 4.75 kPa.

- FLOATING FLOOR 10 mm
- UNDERLAY OF TYPE "INSONOBOIS" 3 mm
- 2 UNDERLAYS OF TYPE "FIBEROCK" 15.9 mm EA.
- UNDERLAY OF TYPE "INSONOMAT" 15 mm
- NORDIC X-LAM 175 mm
- SUSPENDED CEILING:
 - RESILIENT METALLIC HANGERS 200 mm @ 1200 mm O.C.
 - METAL TRACKS @ 600 mm O.C.
 - 2 ROWS OF STONE WOOL INSULATION OF TYPE "ROXUL" (40 kg/m³) 89 mm EA.
- 1 TYPE X GYPSUM BOARD 15.9 mm

Architecture, Assembly

Floor

NS-DA2205

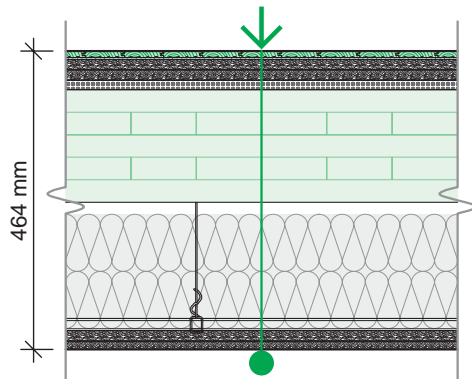

F6

Fire-resistance rating	FRR ^(a)	2 h
Thermal resistance	RSI / R	n.a. / n.a.
Acoustic ratings	STC / ASTC	n.a. / 58
	IIC / AIC	n.a. / 60

a) The fire-resistance rating is based on a span of 5.75 m and on a specified uniform load of 4.75 kPa.

- FLOATING FLOOR 10 mm
- UNDERLAY OF TYPE "INSONOBOIS" 3 mm
- 2 UNDERLAYS OF TYPE "FIBEROCK" 15.9 mm EA.
- UNDERLAY OF TYPE "INSONOMAT" 15 mm
- NORDIC X-LAM 175 mm
- SUSPENDED CEILING:
 - RESILIENT METALLIC HANGERS 200 mm @ 1200 mm O.C.
 - METAL TRACKS @ 600 mm O.C.
 - 2 ROWS OF STONE WOOL INSULATION OF TYPE "ROXUL" (40 kg/m³) 89 mm EA.
- 1 TYPE X GYPSUM BOARD 15.9 mm
- 1 REGULAR GYPSUM BOARD 12.7 mm

Architecture, Assembly

Floor

NS-DA2206

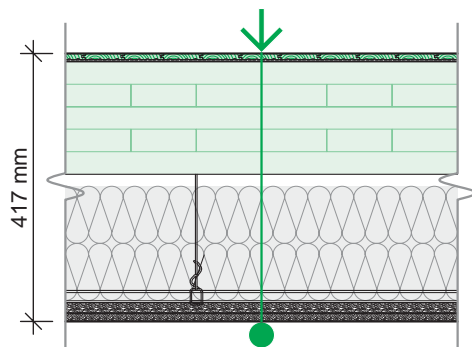

F7

Fire-resistance rating	FRR ^(a)	2 h
Thermal resistance	RSI / R	n.a. / n.a.
Acoustic ratings	STC / ASTC	n.a. / 54
	IIC / AIC	n.a. / 56

a) The fire-resistance rating is based on a span of 5.75 m and on a specified uniform load of 4.75 kPa.

- FLOATING FLOOR 10 mm
- UNDERLAY OF TYPE "INSONOBOIS" 3 mm
- NORDIC X-LAM 175 mm
- SUSPENDED CEILING:
 - RESILIENT METALLIC HANGERS 200 mm @ 1200 mm O.C.
 - METAL TRACKS @ 600 mm O.C.
 - 2 ROWS OF STONE WOOL INSULATION OF TYPE "ROXUL" (40 kg/m³) 89 mm EA.
- 1 TYPE X GYPSUM BOARD 15.9 mm
- 1 REGULAR GYPSUM BOARD 12.7 mm

Architecture, Assembly

Floor

NS-DA2207

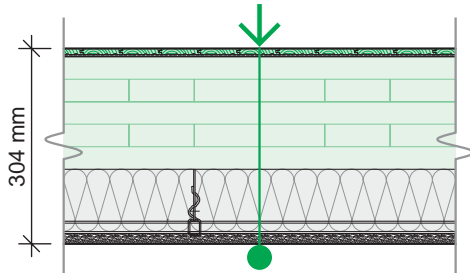

F8

Fire-resistance rating	FRR ^(a)	2 h
Thermal resistance	RSI / R	n.a. / n.a.
Acoustic ratings	STC / ASTC	n.a. / 53
	IIC / AIIIC	n.a. / 52

a) The fire-resistance rating is based on a span of 5.75 m and on a specified uniform load of 4.75 kPa.

- FLOATING FLOOR 10 mm
- UNDERLAY OF TYPE "INSONOBOIS" 3 mm
- NORDIC X-LAM 175 mm
- SUSPENDED CEILING:
 - RESILIENT METALLIC HANGERS 100 mm @ 1200 mm O.C.
 - METAL TRACKS @ 600 mm O.C.
 - 1 ROW OF STONE WOOL INSULATION OF TYPE "ROXUL" (40 kg/m³) 89 mm EA.
 - 1 TYPE X GYPSUM BOARD 15.9 mm

Architecture, Assembly

Floor

NS-DA2208

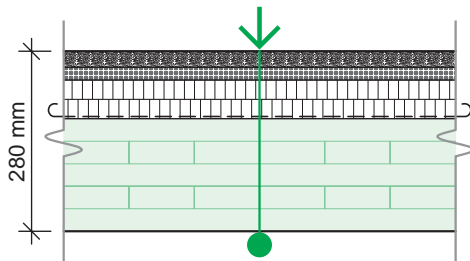

F9

Fire-resistance rating	FRR ^(a)	1.5 h
Thermal resistance	RSI / R	n.a. / n.a.
Acoustic ratings	STC ^(b) / ASTC	62 / n.a.
	IIC ^(b) / AIIIC	59 / n.a.

a) The fire-resistance rating is based on a span of 5.75 m and on a specified uniform load of 4.75 kPa.

b) Composition and acoustic performance taken from the CLT Handbook – U.S. Edition (FPIInnovations, 2013). Acoustic performance based on a CLT thickness of 135 mm.

- GYPSUM FIBREBOARD OF TYPE "FERMACELL" 25 mm
- UNDERLAY OF TYPE "ISOVER EP3" 20 mm
- 2 LAYERS OF PELLETS AND HONEYCOMB CORE OF TYPE "FERMACELL" 30 mm EA.
- KRAFT PAPER UNDERLAY
- NORDIC X-LAM 175 mm

Architecture, Assembly

Floor

NS-DA2209

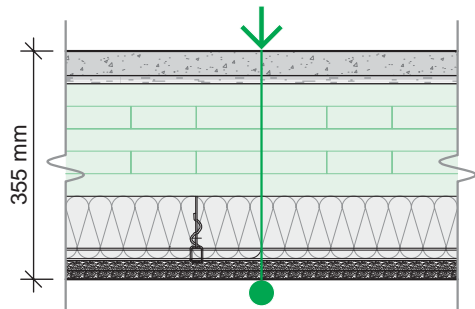

F10

Fire-resistance rating	FRR ^(a)	2 h
Thermal resistance	RSI / R	n.a. / n.a.
Acoustic ratings	STC / ASTC	n.a. / 61
	IIC / AIC	n.a. / 50

a) The fire-resistance rating is based on a span of 5.75 m and on a specified uniform load of 4.75 kPa.

- CONCRETE TOPPING (2000 kg/m³) 38 mm
- WOOD FIBRE ACOUSTIC PANEL OF TYPE "BP ECO-LOGICAL" 12.7 mm
- NORDIC X-LAM 175 mm
- SUSPENDED CEILING:
 - RESILIENT METALLIC HANGERS 100 mm @ 1200 mm O.C.
 - METAL TRACKS @ 600 mm O.C.
 - 1 ROW OF STONE WOOL INSULATION OF TYPE "ROXUL" (40 kg/m³) 89 mm
- 1 TYPE X GYPSUM BOARD 15.9 mm
- 1 REGULAR GYPSUM BOARD 12.7 mm

Architecture, Assembly

Floor

NS-DA2210

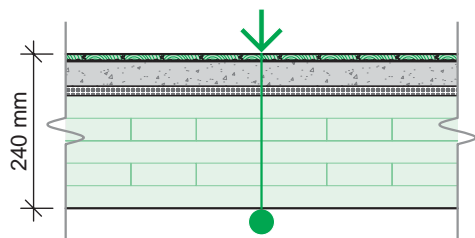

F11

Fire-resistance rating	FRR ^(a)	1.5 h
Thermal resistance	RSI / R	n.a. / n.a.
Acoustic ratings	STC / ASTC	55 / n.a.
	IIC / AIC	51 / n.a.

a) The fire-resistance rating is based on a span of 5.75 m and on a specified uniform load of 4.75 kPa.

- ENGINEERED WOOD FLOOR 10 mm
- UNDERLAY OF TYPE "ROBERTS SOFT STRIDE" 2 mm
- CONCRETE TOPPING 38 mm
- UNDERLAY OF TYPE "INSONOMAT" 15 mm
- NORDIC X-LAM 175 mm

Architecture, Assembly

Floor

NS-DA2211

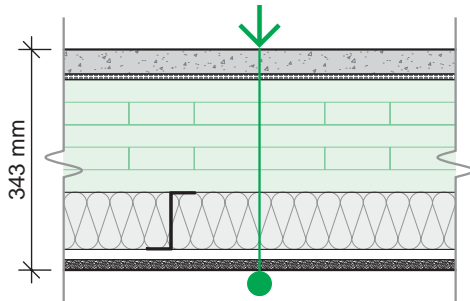

F12

Fire-resistance rating	FRR ^(a)	2 h
Thermal resistance	RSI / R	n.a. / n.a.
Acoustic ratings	STC / ASTC	70 / n.a.
	IIC / AIIIC	56 / n.a.

a) The fire-resistance rating is based on a span of 5.75 m and on a specified uniform load of 4.75 kPa.

- CONCRETE TOPPING 38 mm
- UNDERLAY OF TYPE "OWENS CORNING QUIÉTUDE" 9 mm
- NORDIC X-LAM 175 mm
- Z-CHANNELS (26 GAUGE) 90 mm @ 610 mm O.C.
- 1 ROW OF FIBREGLASS INSULATION OF TYPE "ROSE FIBERGLAS ECOTOUCH" 92 mm
- FURRING CHANNELS 16 mm @ 406 mm O.C.
- 1 TYPE X GYPSUM BOARD 15.9 mm

Architecture, Assembly

Floor

NS-DA2212

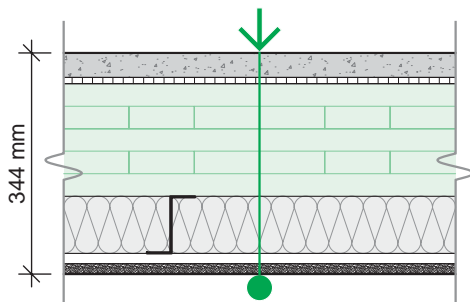

F13

Fire-resistance rating	FRR ^(a)	2 h
Thermal resistance	RSI / R	n.a. / n.a.
Acoustic ratings	STC / ASTC	69 / n.a.
	IIC / AIIIC	54 / n.a.

a) The fire-resistance rating is based on a span of 5.75 m and on a specified uniform load of 4.75 kPa.

- CONCRETE TOPPING 38 mm
- TAR FIBREBOARD 10 mm
- NORDIC X-LAM 175 mm
- Z-CHANNELS (26 GAUGE) 90 mm @ 610 mm O.C.
- 1 ROW OF FIBREGLASS INSULATION OF TYPE "ROSE FIBERGLAS ECOTOUCH" 92 mm
- FURRING CHANNELS 16 mm @ 406 mm O.C.
- 1 TYPE X GYPSUM BOARD 15.9 mm

Architecture, Assembly

Floor

NS-DA2213

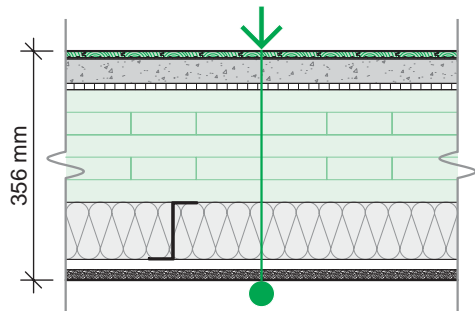

F14

Fire-resistance rating	FRR ^(a)	2 h
Thermal resistance	RSI / R	n.a. / n.a.
	STC / ASTC	69 / n.a.
Acoustic ratings	IIC / AIC	58 / n.a.

a) The fire-resistance rating is based on a span of 5.75 m and on a specified uniform load of 4.75 kPa.

- ENGINEERED WOOD FLOOR 10 mm
- UNDERLAY OF TYPE "ROBERTS SOFT STRIDE" 2 mm
- CONCRETE TOPPING 38 mm
- TAR FIBREBOARD 10 mm
- NORDIC X-LAM 175 mm
- Z-CHANNELS (26 GAUGE) 90 mm @ 610 mm O.C.
- 1 ROW OF FIBREGLASS INSULATION OF TYPE "ROSE FIBERGLAS ECOTOUCH" 92 mm
- FURRING CHANNELS 16 mm @ 406 mm O.C.
- 1 TYPE X GYPSUM BOARD 15.9 mm

Architecture, Assembly

Floor

NS-DA2214

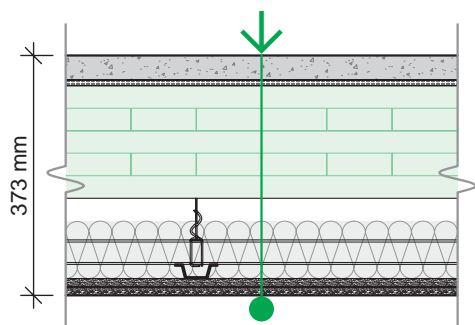

F15

Fire-resistance rating	FRR ^(a)	1.5 h
Thermal resistance	RSI / R	n.a. / n.a.
	STC / ASTC	72 / n.a.
Acoustic ratings	IIC / AIC	65 / n.a.

a) The fire-resistance rating is based on a span of 5.75 m and on a specified uniform load of 4.75 kPa.

- CONCRETE TOPPING 38 mm
- UNDERLAY OF TYPE "OWENS CORNING QUIÉTUDE" 9 mm
- NORDIC X-LAM 175 mm
- SUSPENDED CEILING:
 - METALLIC HANGERS 65 mm
 - CHANNEL IRONS 38 mm @ 1220 mm O.C.
 - FURRING CHANNELS 22 mm @ 406 mm O.C.
 - 1 ROW OF FIBREGLASS INSULATION OF TYPE "ROSE FIBERGLAS ECOTOUCH" 92 mm
- 2 TYPE C GYPSUM BOARDS 12.7 mm EA.

Architecture, Assembly

Floor

NS-DA2215

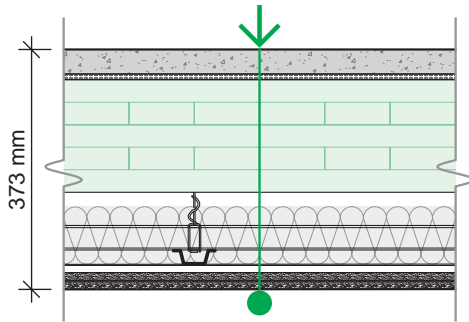

F16

Fire-resistance rating	FRR ^(a)	1.5 h
Thermal resistance	RSI / R	n.a. / n.a.
Acoustic ratings	STC / ASTC	73 / n.a.
	IIC / AIIIC	66 / n.a.

a) The fire-resistance rating is based on a span of 5.75 m and on a specified uniform load of 4.75 kPa.

- CONCRETE TOPPING 38 mm
- UNDERLAY OF TYPE "OWENS CORNING QUIÉTUDE" 9 mm
- NORDIC X-LAM 175 mm
- SUSPENDED CEILING:
 - METALLIC HANGERS 52 mm
 - CHANNEL IRONS 38 mm @ 1220 mm O.C.
 - FURRING CHANNELS 22 mm @ 406 mm O.C.
 - 1 ROW OF FIBREGLASS INSULATION OF TYPE "ROSE FIBERGLAS ECOTOUCH" 92 mm
- RESILIENT CHANNELS 13 mm @ 610 mm O.C.
- 2 TYPE C GYPSUM BOARDS 12.7 mm EA.

Architecture, Assembly

Floor

NS-DA2216

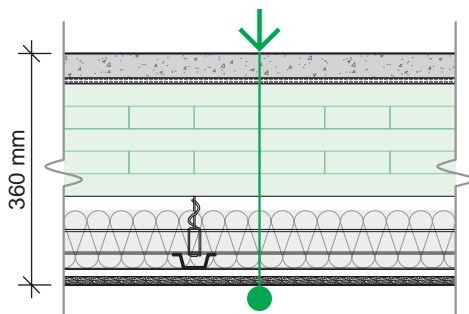

F17

Fire-resistance rating	FRR ^(a)	1.5 h
Thermal resistance	RSI / R	n.a. / n.a.
Acoustic ratings	STC / ASTC	72 / n.a.
	IIC / AIIIC	62 / n.a.

a) The fire-resistance rating is based on a span of 5.75 m and on a specified uniform load of 4.75 kPa.

- CONCRETE TOPPING 38 mm
- UNDERLAY OF TYPE "OWENS CORNING QUIÉTUDE" 9 mm
- NORDIC X-LAM 175 mm
- SUSPENDED CEILING:
 - METALLIC HANGERS 52 mm
 - CHANNEL IRONS 38 mm @ 1220 mm O.C.
 - FURRING CHANNELS 22 mm @ 406 mm O.C.
 - 1 ROW OF FIBREGLASS INSULATION OF TYPE "ROSE FIBERGLAS ECOTOUCH" 92 mm
- RESILIENT CHANNELS 13 mm @ 610 mm O.C.
- 1 TYPE C GYPSUM BOARD 12.7 mm

Architecture, Assembly

Floor

NS-DA2220

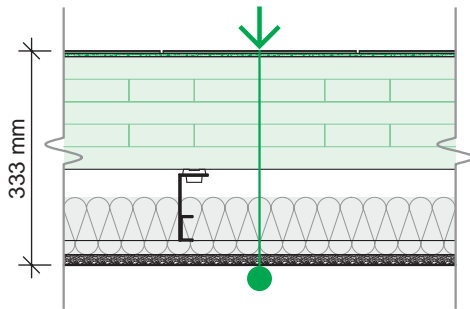

F21

Fire-resistance rating	FRR ^(a)	2 h
Thermal resistance	RSI / R	n.a. / n.a.
Acoustic ratings	STC / ASTC	58 / n.a.
	IIC / AIC	58 / n.a.

a) The fire-resistance rating is based on a span of 5.75 m and on a specified uniform load of 4.75 kPa.

- VINYL TILES FLOORING 4 mm
- UNDERLAY OF TYPE "GENIEMAT RST05" 5 mm
- NORDIC X-LAM 175 mm
- SUSPENDED CEILING:
 - BRACKETS OF TYPE "GENIECLIP LB" 111 mm
 - CHANNEL IRONS 38 mm @ 1220 mm O.C. FIXED AT THE BOTTOM OF THE BRACKETS
 - FURRING CHANNELS 22 mm @ 610 mm O.C.
 - 1 ROW OF FIBREGLASS INSULATION OF TYPE "JOHNS MANVILLE UNFACED BATTS R13" 89 mm
- 1 TYPE X GYPSUM BOARD 15.9 mm

Architecture, Assembly

Floor

NS-DA2221

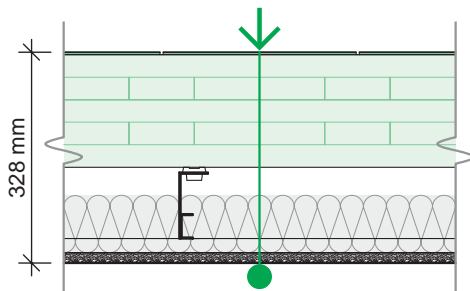

F22

Fire-resistance rating	FRR ^(a)	2 h
Thermal resistance	RSI / R	n.a. / n.a.
Acoustic ratings	STC / ASTC	57 / n.a.
	IIC / AIC	54 / n.a.

a) The fire-resistance rating is based on a span of 5.75 m and on a specified uniform load of 4.75 kPa.

- VINYL TILES FLOORING 4 mm
- NORDIC X-LAM 175 mm
- SUSPENDED CEILING:
 - BRACKETS OF TYPE "GENIECLIP LB" 111 mm
 - CHANNEL IRONS 38 mm @ 1220 mm O.C. FIXED AT THE BOTTOM OF THE BRACKETS
 - FURRING CHANNELS 22 mm @ 610 mm O.C.
 - 1 ROW OF FIBREGLASS INSULATION OF TYPE "JOHNS MANVILLE UNFACED BATTS R13" 89 mm
- 1 TYPE X GYPSUM BOARD 15.9 mm

Architecture, Assembly

Floor

NS-DA2222

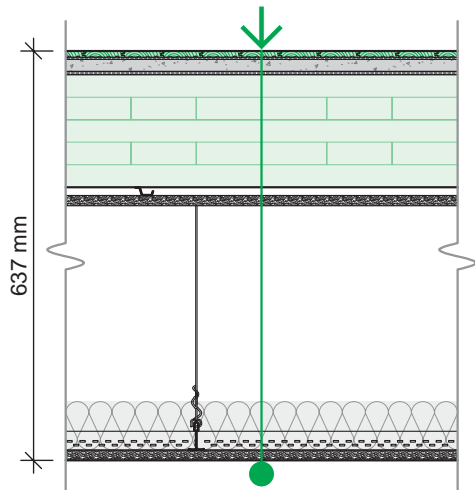

F23

Fire-resistance rating	FRR ^(a)	2.5 h
Thermal resistance	RSI / R	n.a. / n.a.
Acoustic ratings	STC / ASTC	n.a. / 54
	IIC / AIC	n.a. / 53

a) The fire-resistance rating is based on a span of 5.75 m and on a specified uniform load of 4.75 kPa.

- FLOATING FLOOR 10 mm
- UNDERLAY OF TYPE "INSONOBOIS" 3.5 mm
- TOPPING OF TYPE "MAXXON GYP-CRETE" (2050 kg/m³) 19 mm
- ENTANGLED FILAMENT MAT OF TYPE "MAXXON ACOUSTI-MAT 1" 5 mm
- NORDIC X-LAM 175 mm
- RESILIENT CHANNELS 13 mm @ 610 mm O.C.
- 1 TYPE X GYPSUM BOARD OF TYPE "QUIETROCK" 15.9 mm
- SUSPENDED DRYWALL GRID SYSTEM OF TYPE "ARMSTRONG":
 - METALLIC HANGERS 380 mm
 - T-CHANNELS 43 mm @ 1220 mm O.C.
- 1 ROW OF STONE WOOL INSULATION OF TYPE "ROXUL" (40 kg/m³) 75 mm
- 1 TYPE X GYPSUM BOARD 15.9 mm

Architecture, Assembly

Floor

NS-DA2223

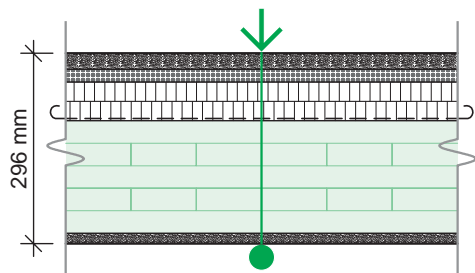

F24

Fire-resistance rating	FRR ^(a)	2 h
Thermal resistance	RSI / R	n.a. / n.a.
Acoustic ratings	STC ^(b) / ASTC	62 / n.a.
	IIC ^(b) / AIC	59 / n.a.

a) The fire-resistance rating is based on a span of 5.75 m and on a specified uniform load of 4.75 kPa.

b) Composition and acoustic performance taken from the CLT Handbook – U.S. Edition (FPInnovations, 2013). Acoustic performance based on a CLT thickness of 135 mm.

- GYPSUM FIBERBOARD OF TYPE "FERMACELL" 25 mm
- UNDERLAY OF TYPE "ISOVER EP3" 20 mm
- 2 LAYERS OF PELLETS AND HONEYCOMB CORE OF TYPE "FERMACELL" 30 mm EA.
- KRAFT PAPER UNDERLAY
- NORDIC X-LAM 175 mm
- 1 TYPE X GYPSUM BOARD 15.9 mm

Architecture, Assembly

Floor

NS-DA2224

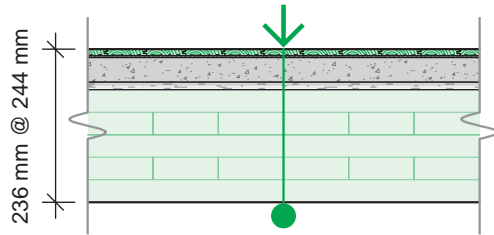

F25

Fire-resistance rating	FRR ^(a)	1.5 h
Thermal resistance	RSI / R	n.a. / n.a.
Acoustic ratings	STC / ASTC ^(b)	n.a. / > 50
	IIC / AIIC ^(b)	n.a. / > 50

- a) The fire-resistance rating is based on a span of 5.75 m and on a specified uniform load of 4.75 kPa.
- b) Composition and acoustic performance taken from the CLT Handbook – U.S. Edition (FPIInnovations, 2013). Acoustic performance based on a CLT thickness of 135 mm.
- CARPET OR FLOATING FLOOR 10 mm
 - RESILIENT UNDERLAY (RUBBER OR FELT) 3 mm
 - TOPPING, AT LEAST 76 kg/m² (I.E. CONCRETE OR OF TYPE "MAXXON GYP-CRETE")
 - RESILIENT UNDERLAY (RUBBER 10 mm, FELT 18 mm, OR WOOD FIBERBOARD 12 mm)
 - NORDIC X-LAM 175 mm

Architecture, Assembly

Floor

NS-DA2225

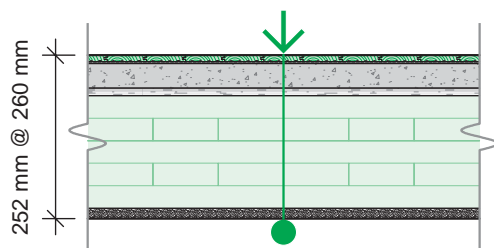

F26

Fire-resistance rating	FRR ^(a)	2 h
Thermal resistance	RSI / R	n.a. / n.a.
Acoustic ratings	STC / ASTC ^(b)	n.a. / > 50
	IIC / AIIC ^(b)	n.a. / > 50

- a) The fire-resistance rating is based on a span of 5.75 m and on a specified uniform load of 4.75 kPa.
- b) Composition and acoustic performance taken from the CLT Handbook – U.S. Edition (FPIInnovations, 2013). Acoustic performance based on a CLT thickness of 135 mm.
- CARPET OR FLOATING FLOOR 10 mm
 - RESILIENT UNDERLAY (RUBBER OR FELT) 3 mm
 - TOPPING, AT LEAST 76 kg/m² (I.E. CONCRETE OR OF TYPE "MAXXON GYP-CRETE")
 - RESILIENT UNDERLAY (RUBBER 10 mm, FELT 18 mm, OR WOOD FIBERBOARD 12 mm)
 - NORDIC X-LAM 175 mm
 - 1 TYPE X GYPSUM BOARD 15.9 mm

Architecture, Assembly

Floor

NS-DA2226

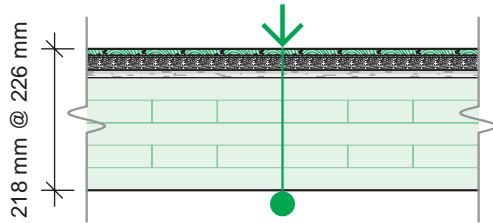

F27

Fire-resistance rating	FRR ^(a)	1.5 h
Thermal resistance	RSI / R	n.a. / n.a.
	STC / ASTC ^(b)	n.a. / > 45
Acoustic ratings	IIC / AIC ^(b)	n.a. / > 45

- a) The fire-resistance rating is based on a span of 5.75 m and on a specified uniform load of 4.75 kPa.
- b) Composition and acoustic performance taken from the CLT Handbook – U.S. Edition (FPInnovations, 2013). Acoustic performance based on a CLT thickness of 135 mm.

- CARPET OR FLOATING FLOOR 10 mm
- RESILIENT UNDERLAY (RUBBER OR FELT) 3 mm
- PREFABRICATED TOPPING, AT LEAST 25 kg/m² (20 mm OF TYPE "FERMACELL" OR OF TYPE "FIBREROCK")
- RESILIENT UNDERLAY (RUBBER 10 mm, FELT 18 mm, OR WOOD FIBERBOARD 12 mm)
- NORDIC X-LAM 175 mm

Architecture, Assembly

Floor

NS-DA2227

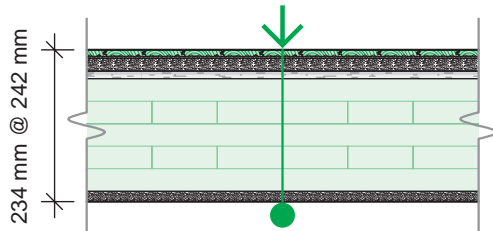

F28

Fire-resistance rating	FRR ^(a)	2 h
Thermal resistance	RSI / R	n.a. / n.a.
	STC / ASTC ^(b)	n.a. / > 45
Acoustic ratings	IIC / AIC ^(b)	n.a. / > 45

- a) The fire-resistance rating is based on a span of 5.75 m and on a specified uniform load of 4.75 kPa.
- b) Composition and acoustic performance taken from the CLT Handbook – U.S. Edition (FPInnovations, 2013). Acoustic performance based on a CLT thickness of 135 mm.

- CARPET OR FLOATING FLOOR 10 mm
- RESILIENT UNDERLAY (RUBBER OR FELT) 3 mm
- PREFABRICATED TOPPING, AT LEAST 25 kg/m² (20 mm OF TYPE "FERMACELL" OR OF TYPE "FIBREROCK")
- RESILIENT UNDERLAY (RUBBER 10 mm, FELT 18 mm, OR WOOD FIBERBOARD 12 mm)
- NORDIC X-LAM 175 mm
- 1 TYPE X GYPSUM BOARD 15.9 mm

Architecture, Assembly

Floor

NS-DA2228

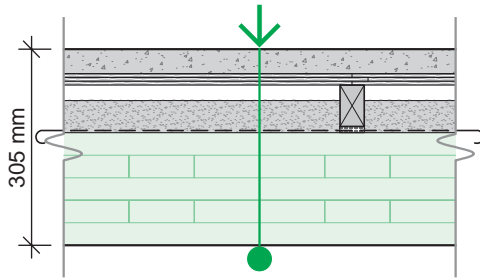

F29

Fire-resistance rating	FRR ^(a)	1.5 h
Thermal resistance	RSI / R	n.a. / n.a.
Acoustic ratings	STC ^(b) / ASTC	64 / n.a.
	IIC ^(b) / AIIIC	53 / n.a.

a) The fire-resistance rating is based on a span of 5.75 m and on a specified uniform load of 4.75 kPa.

b) Acoustic performance based on a CLT thickness of 131 mm.

- PREFABRICATED CONCRETE TOPPING 38 mm
- TONGUE AND GROOVE OSB SHEATHING 18 mm
- WOOD RAFTERS 38 mm X 64 mm @ 610 mm O.C.
- SILICA SAND (#71) 50 mm
- RUBBER MEMBRANE BANDS 10 mm UNDER RAFTERS
- POLYETHYLENE SHEETING 6 mil
- NORDIC X-LAM 175 mm

Architecture, Assembly

Floor

NS-DA2229

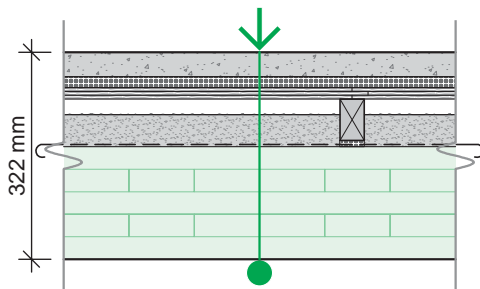

F30

Fire-resistance rating	FRR ^(a)	1.5 h
Thermal resistance	RSI / R	n.a. / n.a.
Acoustic ratings	STC ^(b) / ASTC	66 / n.a.
	IIC ^(b) / AIIIC	60 / n.a.

a) The fire-resistance rating is based on a span of 5.75 m and on a specified uniform load of 4.75 kPa.

b) Acoustic performance based on a CLT thickness of 131 mm.

- PREFABRICATED CONCRETE TOPPING 38 mm
- UNDERLAY OF TYPE "REGUPOL SONUS WAVE" 17 mm
- TONGUE AND GROOVE OSB SHEATHING 18 mm
- WOOD RAFTERS 38 mm X 64 mm @ 610 mm O.C.
- SILICA SAND (#71) 50 mm
- RUBBER MEMBRANE BANDS 10 mm UNDER RAFTERS
- POLYETHYLENE SHEETING 6 mil
- NORDIC X-LAM 175 mm

Architecture, Assembly

Floor

NS-DA2230

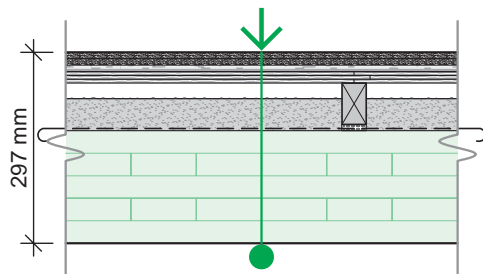

F31

Fire-resistance rating	FRR ^(a)	1.5 h
Thermal resistance	RSI / R	n.a. / n.a.
	STC ^(b) / ASTC	59 / n.a.
Acoustic ratings	IIC ^(b) / AIC	53 / n.a.

a) The fire-resistance rating is based on a span of 5.75 m and on a specified uniform load of 4.75 kPa.

b) Acoustic performance based on a CLT thickness of 131 mm.

- UNDERLAY OF TYPE "FERMACELL 2E31" 30 mm
- TONGUE AND GROOVE OSB SHEATHING 18 mm
- WOOD RAFTERS 38 mm X 64 mm @ 610 mm O.C.
- SILICA SAND (#71) 50 mm
- RUBBER MEMBRANE BANDS 10 mm UNDER RAFTERS
- POLYETHYLENE SHEETING 6 mil
- NORDIC X-LAM 175 mm

Architecture, Assembly

Floor

NS-DA2231

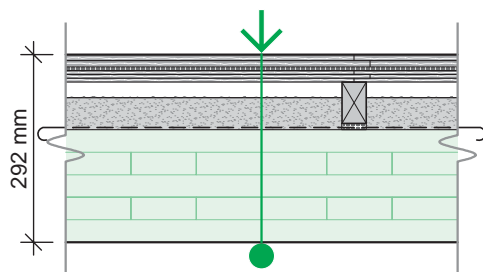

F32

Fire-resistance rating	FRR ^(a)	1.5 h
Thermal resistance	RSI / R	n.a. / n.a.
	STC ^(b) / ASTC	56 / n.a.
Acoustic ratings	IIC ^(b) / AIC	50 / n.a.

a) The fire-resistance rating is based on a span of 5.75 m and on a specified uniform load of 4.75 kPa.

b) Acoustic performance based on a CLT thickness of 131 mm.

- UNDERLAY OF TYPE "SONODECK INSULFLOOR" 25 mm
- TONGUE AND GROOVE OSB SHEATHING 18 mm
- WOOD RAFTERS 38 mm X 64 mm @ 610 mm O.C.
- SILICA SAND (#71) 50 mm
- RUBBER MEMBRANE BANDS 10 mm UNDER RAFTERS
- POLYETHYLENE SHEETING 6 mil
- NORDIC X-LAM 175 mm

Architecture, Assembly

Floor

NS-DA2232

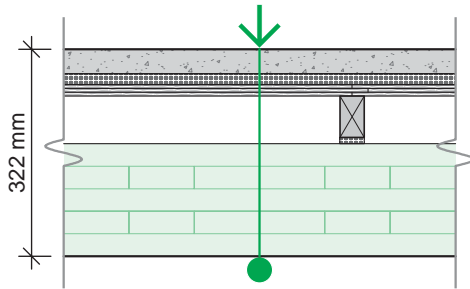

F33

Fire-resistance rating	FRR ^(a)	1.5 h
Thermal resistance	RSI / R	n.a. / n.a.
Acoustic ratings	STC ^(b) / ASTC	59 / n.a.
	IIC ^(b) / AIIIC	54 / n.a.

a) The fire-resistance rating is based on a span of 5.75 m and on a specified uniform load of 4.75 kPa.

b) Acoustic performance based on a CLT thickness of 131 mm.

- PREFABRICATED CONCRETE TOPPING 38 mm
- UNDERLAY OF TYPE "REGUPOL SONUS WAVE" 17 mm
- TONGUE AND GROOVE OSB SHEATHING 18 mm
- WOOD RAFTERS 38 mm X 64 mm @ 610 mm O.C.
- RUBBER MEMBRANE BANDS 10 mm UNDER RAFTERS
- NORDIC X-LAM 175 mm

Architecture, Assembly

Floor

NS-DA2233

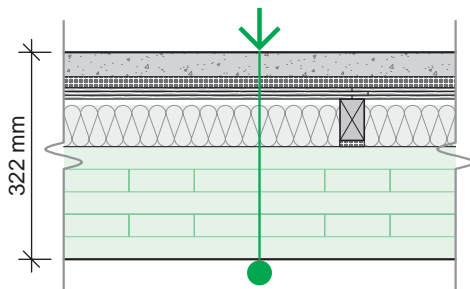

F34

Fire-resistance rating	FRR ^(a)	1.5 h
Thermal resistance	RSI / R	n.a. / n.a.
Acoustic ratings	STC ^(b) / ASTC	60 / n.a.
	IIC ^(b) / AIIIC	54 / n.a.

a) The fire-resistance rating is based on a span of 5.75 m and on a specified uniform load of 4.75 kPa.

b) Acoustic performance based on a CLT thickness of 131 mm.

- PREFABRICATED CONCRETE TOPPING 38 mm
- UNDERLAY OF TYPE "REGUPOL SONUS WAVE" 17 mm
- TONGUE AND GROOVE OSB SHEATHING 18 mm
- WOOD RAFTERS 38 mm X 64 mm @ 610 mm O.C.
- 1 ROW OF FIBERGLASS INSULATION 65 mm
- RUBBER MEMBRANE BANDS 10 mm UNDER RAFTERS
- NORDIC X-LAM 175 mm

Architecture, Assembly

Floor

NS-DA2235

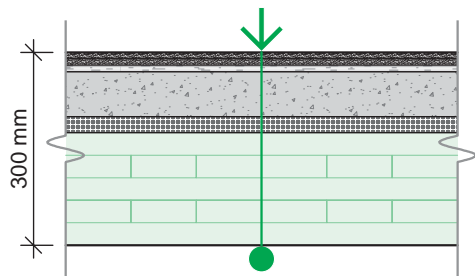

F36

Fire-resistance rating	FRR ^(a)	1.5 h
Thermal resistance	RSI / R	n.a. / n.a.
Acoustic ratings	STC ^(b) / ASTC	56 / n.a.
	IIC ^(b) / AIIIC	52 / n.a.

a) The fire-resistance rating is based on a span of 5.75 m and on a specified uniform load of 4.75 kPa.

b) Acoustic performance based on a CLT thickness of 131 mm.

- UNDERLAY OF TYPE "FERMACELL 2E31" 30 mm
- PREFABRICATED CONCRETE TOPPING (2350 kg/m³) 70 mm
- UNDERLAY OF TYPE "REGUPOL SONUS WAVE" 25 mm
- NORDIC X-LAM 175 mm

Architecture, Assembly

Floor

NS-DA2236

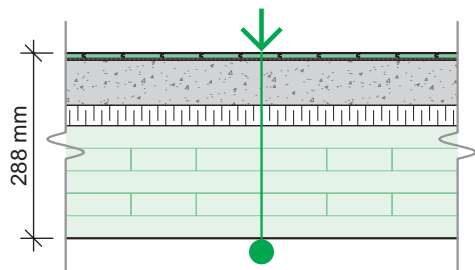

F37

Fire-resistance rating	FRR ^(a)	1.5 h
Thermal resistance	RSI / R	n.a. / n.a.
Acoustic ratings	STC ^(b) / ASTC	57 / n.a.
	IIC ^(b) / AIIIC	51 / n.a.

a) The fire-resistance rating is based on a span of 5.75 m and on a specified uniform load of 4.75 kPa.

b) Acoustic performance based on a CLT thickness of 131 mm.

- LAMINATED FLOORING 8 mm
- UNDERLAY OF TYPE "ACOUSTITECH PREMIUM" 3 mm
- PREFABRICATED CONCRETE TOPPING (2350 kg/m³) 70 mm
- RIGID SHEATHING BOARD OF TYPE "ROXUL COMFORTBOARD IS" 32 mm
- NORDIC X-LAM 175 mm

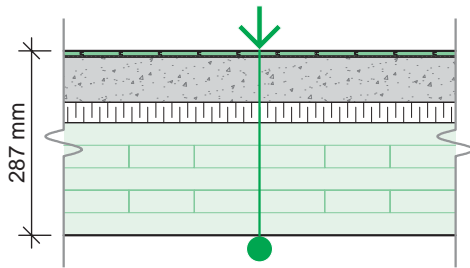

F38

Fire-resistance rating	FRR ^(a)	1.5 h
Thermal resistance	RSI / R	n.a. / n.a.
Acoustic ratings	STC ^(b) / ASTC	57 / n.a.
	IIC ^(b) / AIIIC	51 / n.a.

- a) The fire-resistance rating is based on a span of 5.75 m and on a specified uniform load of 4.75 kPa.
 b) Acoustic performance based on a CLT thickness of 131 mm.

- LAMINATED FLOORING 8 mm
- UNDERLAY OF TYPE "ROBERTS SOFT STRIDE" 2 mm
- PREFABRICATED CONCRETE TOPPING (2350 kg/m³) 70 mm
- RIGID SHEATHING BOARD OF TYPE "ROXUL COMFORTBOARD IS" 32 mm
- NORDIC X-LAM 175 mm

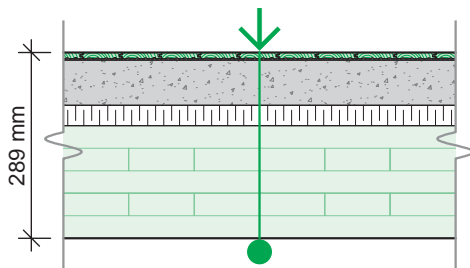

F39

Fire-resistance rating	FRR ^(a)	1.5 h
Thermal resistance	RSI / R	n.a. / n.a.
Acoustic ratings	STC ^(b) / ASTC	57 / n.a.
	IIC ^(b) / AIIIC	51 / n.a.

- a) The fire-resistance rating is based on a span of 5.75 m and on a specified uniform load of 4.75 kPa.
 b) Acoustic performance based on a CLT thickness of 131 mm.

- HARDWOOD FLOORING OF TYPE "TORLYS EVEREST PREMIER" 10 mm
- UNDERLAY OF TYPE "ROBERTS SOFT STRIDE" 2 mm
- PREFABRICATED CONCRETE TOPPING (2350 kg/m³) 70 mm
- RIGID SHEATHING BOARD OF TYPE "ROXUL COMFORTBOARD IS" 32 mm
- NORDIC X-LAM 175 mm

Architecture, Assembly

Floor

NS-DA2239

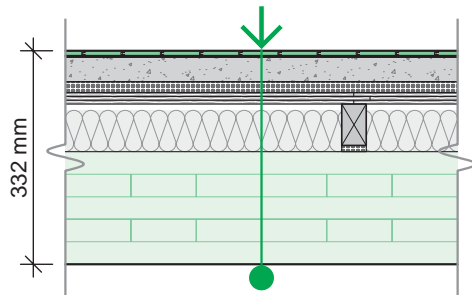

F40

Fire-resistance rating	FRR ^(a)	1.5 h
Thermal resistance	RSI / R	n.a. / n.a.
	STC ^(b) / ASTC	60 / n.a.
Acoustic ratings	IIC ^(b) / AIC	58 / n.a.

a) The fire-resistance rating is based on a span of 5.75 m and on a specified uniform load of 4.75 kPa.

b) Acoustic performance based on a CLT thickness of 131 mm.

- LAMINATED FLOORING 8 mm
- UNDERLAY OF TYPE "ROBERTS SOFT STRIDE" 2 mm
- PREFABRICATED CONCRETE TOPPING 38 mm
- UNDERLAY OF TYPE "REGUPOL SONUS WAVE" 17 mm
- TONGUE AND GROOVE OSB SHEATHING 18 mm
- WOOD RAFTERS 38 mm X 64 mm @ 610 mm O.C.
- 1 ROW OF FIBERGLASS INSULATION 65 mm
- RUBBER MEMBRANE BANDS 10 mm UNDER RAFTERS
- NORDIC X-LAM 175 mm

Architecture, Assembly

Roof

NS-DA2300

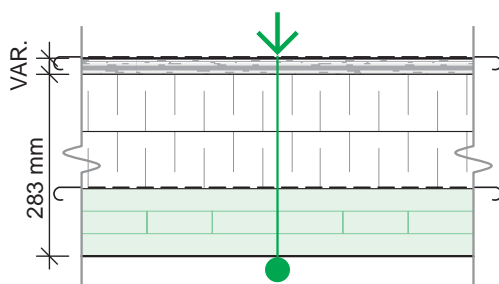

R1

Fire-resistance rating	FRR ^(a)	1 h
Thermal resistance	RSI / R	7.9 / 45
	STC / ASTC	n.a. / n.a.
Acoustic ratings	IIC / AIC	n.a. / n.a.

a) The fire-resistance rating is based on a span of 3.5 m and on a specified uniform load of 4.5 kPa.

- TWO-LAYER ELASTOMERIC MEMBRANE ROOFING
- ROOFING UNDERLAY (UP TO THE DESIGNER)
- 2 ROWS OF POLYISOCYANURATE INSULATION 89 mm EA.
- VAPOUR BARRIER MEMBRANE
- NORDIC X-LAM 105 mm

Architecture, Assembly

Roof

NS-DA2301

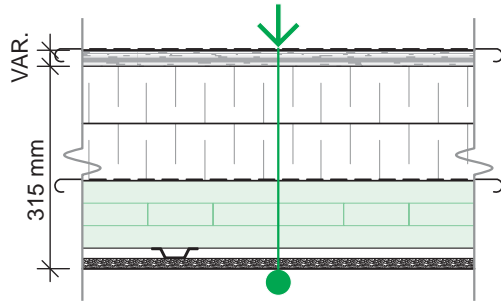

R2

Fire-resistance rating	FRR ^(a)	1.5 h
Thermal resistance	RSI / R	8.2 / 47
Acoustic ratings	STC / ASTC	n.a. / n.a.
	IIC / AIIIC	n.a. / n.a.

a) The fire-resistance rating is based on a span of 3.5 m and on a specified uniform load of 4.5 kPa.

- TWO-LAYER ELASTOMERIC MEMBRANE ROOFING
- ROOFING UNDERLAY (UP TO THE DESIGNER)
- 2 ROWS OF POLYISOCYANURATE INSULATION 89 mm EA.
- VAPOUR BARRIER MEMBRANE
- NORDIC X-LAM 105 mm
- FURRING CHANNELS 16 mm @ 406 mm O.C.
- 1 TYPE X GYPSUM BOARD 15.9 mm

Architecture, Assembly

Roof

NS-DA2302

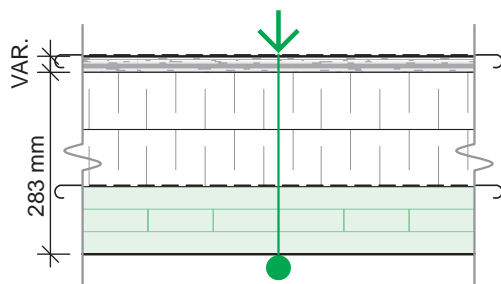

R3

Fire-resistance rating	FRR ^(a)	1 h
Thermal resistance	RSI / R	7.9 / 45
Acoustic ratings	STC / ASTC	n.a. / n.a.
	IIC / AIIIC	n.a. / n.a.

a) The fire-resistance rating is based on a span of 3.5 m and on a specified uniform load of 4.5 kPa.

- THERMOPLASTIC POLYOLEFIN (TPO) MEMBRANE ROOFING
- ROOFING UNDERLAY (UP TO THE DESIGNER)
- 2 ROWS OF POLYISOCYANURATE INSULATION 89 mm EA.
- VAPOUR BARRIER MEMBRANE
- NORDIC X-LAM 105 mm

Architecture, Assembly

Roof

NS-DA2303

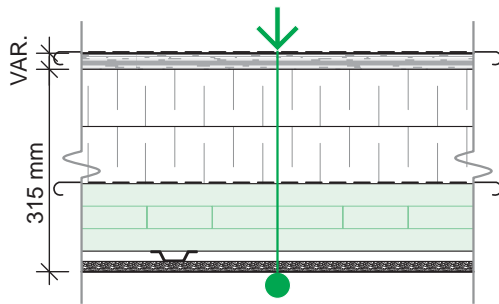

R4

Fire-resistance rating	FRR ^(a)	1.5 h
Thermal resistance	RSI / R	8.2 / 47
Acoustic ratings	STC / ASTC	n.a. / n.a.
	IIC / AIC	n.a. / n.a.

a) The fire-resistance rating is based on a span of 3.5 m and on a specified uniform load of 4.5 kPa.

- THERMOPLASTIC POLYOLEFIN (TPO) MEMBRANE ROOFING
- ROOFING UNDERLAY (UP TO THE DESIGNER)
- 2 ROWS OF POLYISOCYANURATE INSULATION 89 mm EA.
- VAPOUR BARRIER MEMBRANE
- NORDIC X-LAM 105 mm
- FURRING CHANNELS 16 mm @ 406 mm O.C.
- 1 TYPE X GYPSUM BOARD 15.9 mm

Architecture, Assembly

Roof

NS-DA2304

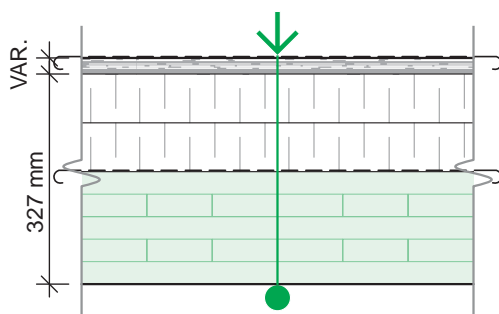

R5

Fire-resistance rating	FRR ^(a)	1.5 h
Thermal resistance	RSI / R	7.5 / 43
Acoustic ratings	STC / ASTC	n.a. / n.a.
	IIC / AIC	n.a. / n.a.

a) The fire-resistance rating is based on a span of 5.75 m and on a specified uniform load of 4.75 kPa.

- TWO-LAYER ELASTOMERIC MEMBRANE ROOFING
- ROOFING UNDERLAY (UP TO THE DESIGNER)
- 2 ROWS OF POLYISOCYANURATE INSULATION 76 mm EA.
- VAPOUR BARRIER MEMBRANE
- NORDIC X-LAM 175 mm

Architecture, Assembly

Roof

NS-DA2305

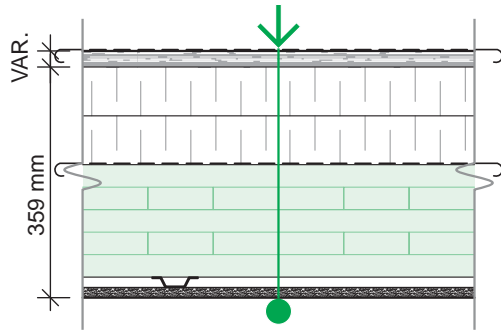

R6

Fire-resistance rating	FRR ^(a)	2 h
Thermal resistance	RSI / R	7.7 / 44
Acoustic ratings	STC / ASTC	n.a. / n.a.
	IIC / AIIIC	n.a. / n.a.

a) The fire-resistance rating is based on a span of 5.75 m and on a specified uniform load of 4.75 kPa.

- TWO-LAYER ELASTOMERIC MEMBRANE ROOFING
- ROOFING UNDERLAY (UP TO THE DESIGNER)
- 2 ROWS OF POLYISOCYANURATE INSULATION 76 mm EA.
- VAPOUR BARRIER MEMBRANE
- NORDIC X-LAM 175 mm
- FURRING CHANNELS 16 mm @ 406 mm O.C.
- 1 TYPE X GYPSUM BOARD 15.9 mm

Architecture, Assembly

Roof

NS-DA2306

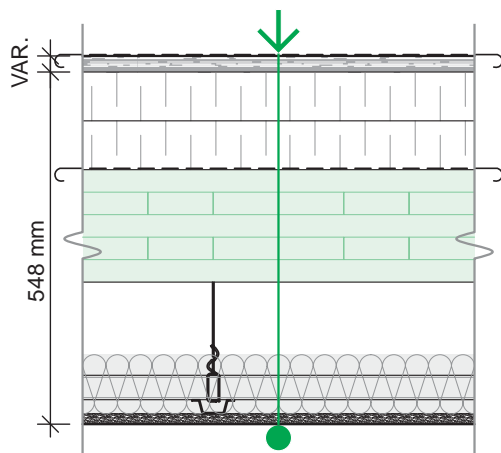

R7

Fire-resistance rating	FRR ^(a)	2 h
Thermal resistance	RSI / R	7.7 / 44
Acoustic ratings	STC / ASTC	n.a. / n.a.
	IIC / AIIIC	n.a. / n.a.

a) The fire-resistance rating is based on a span of 5.75 m and on a specified uniform load of 4.75 kPa.

- TWO-LAYER ELASTOMERIC MEMBRANE ROOFING
- ROOFING UNDERLAY (UP TO THE DESIGNER)
- 2 ROWS OF POLYISOCYANURATE INSULATION 76 mm EA.
- VAPOUR BARRIER MEMBRANE
- NORDIC X-LAM 175 mm
- SUSPENDED CEILING:
 - METALLIC HANGERS 145 mm
 - CHANNEL IRONS 38 mm @ 1220 mm O.C.
 - FURRING CHANNELS 22 mm @ 406 mm O.C.
 - SOUNDPROOFING MATERIAL 92 mm
- 1 TYPE X GYPSUM BOARD 15.9 mm

Architecture, Assembly

Roof

NS-DA2307

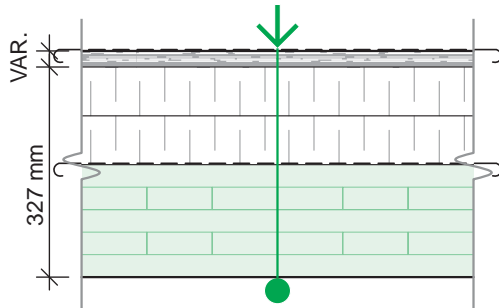

R8

Fire-resistance rating	FRR ^(a)	1.5 h
Thermal resistance	RSI / R	7.5 / 43
Acoustic ratings	STC / ASTC	n.a. / n.a.
	IIC / AIC	n.a. / n.a.

a) The fire-resistance rating is based on a span of 5.75 m and on a specified uniform load of 4.75 kPa.

- THERMOPLASTIC POLYOLEFIN (TPO) MEMBRANE ROOFING
- ROOFING UNDERLAY (UP TO THE DESIGNER)
- 2 ROWS OF POLYISOCYANURATE INSULATION 76 mm EA.
- VAPOUR BARRIER MEMBRANE
- NORDIC X-LAM 175 mm

Architecture, Assembly

Roof

NS-DA2308

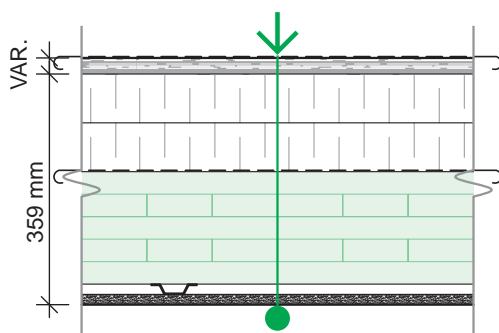

R9

Fire-resistance rating	FRR ^(a)	2 h
Thermal resistance	RSI / R	7.7 / 44
Acoustic ratings	STC / ASTC	n.a. / n.a.
	IIC / AIC	n.a. / n.a.

a) The fire-resistance rating is based on a span of 5.75 m and on a specified uniform load of 4.75 kPa.

- THERMOPLASTIC POLYOLEFIN (TPO) MEMBRANE ROOFING
- ROOFING UNDERLAY (UP TO THE DESIGNER)
- 2 ROWS OF POLYISOCYANURATE INSULATION 76 mm EA.
- VAPOUR BARRIER MEMBRANE
- NORDIC X-LAM 175 mm
- FURRING CHANNELS 16 mm @ 406 mm O.C.
- 1 TYPE X GYPSUM BOARD 15.9 mm

NORDIC

TECHNICAL GUIDE
NORDIC X-LAM

NS-GT6 

ENGLISH
VERSION
2026-02-01

ADDITIONAL
INFORMATION

5

Software



Nordic Sizer

Nordic Sizer is a software program built to design individual structural elements (joists, beams, columns, studs, slabs, and panels) using the full range of Nordic engineered wood products.

Nordic Sizer software application analyzes and designs members for specified loads in accordance with CSA O86 (Canada) or NDS (United States) standard, and automatically checks load cases and load combinations in accordance with NBC (Canada) or IBC (United States). Features include floor vibration checks and fire resistance calculations.

For more information: <http://woodworks-software.com>

DOWNLOAD & INSTALL

Fill in the [form](http://contact.nordic.ca/en/nordic-sizer-software-request/) (contact.nordic.ca/en/nordic-sizer-software-request/) to receive instructions by email within the next business day.

For assistance, please contact the technical support at 514-871-8526, ext. 2 or tech@nordic.ca.

WOODWORKS SOFTWARE TUTORIALS

Canadian Training Videos and User Guide

woodworks-software.com/support/support-canadian-edition/

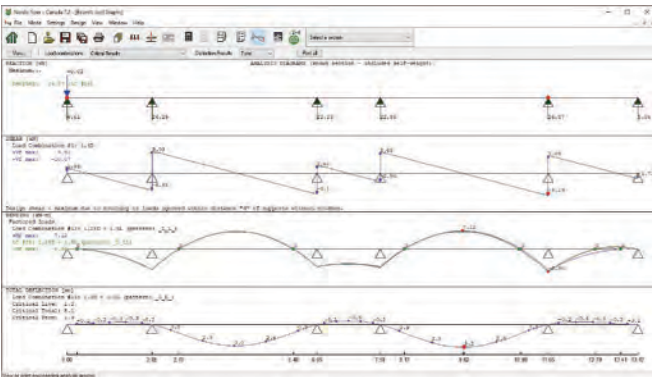

NORDIC STRUCTURES	COMPANY	PROJECT
	Aug. 12, 2020 15:47	Beam1

Design Check Calculation Sheet

Nordic Sizer – Canada 7.2

Loads:

Load	Type	Distribution	Pat-tern	Location [m]	Magnitude	Unit
				Start	End	
Load1	Dead	Full Area	No		2.72(1.00m)	kN/m2
Load2	Live	Full Area	Yes		1.90(1.00m)	kN/m2
Self-weight	Dead	Full UDL	No		0.72	kN/m

Maximum Reactions (kN), Bearing Resistances (kN) and Bearing Lengths (mm) :

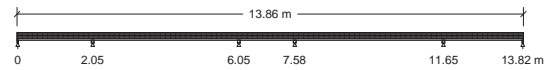

	1.54	12.59		9.22	9.56	12.87	1.79
Unfactored:							
Dead	1.54	12.59		9.22	9.56	12.87	1.79
Live	1.79	7.04		7.14	7.28	7.19	1.88
Factored:							
Uplift	0.02						
Total	4.61	26.29		22.23	22.86	26.87	5.06
Bearing:							
Capacity							
Beam	161.54	282.46		305.35	304.13	282.38	161.54
Des ratio							
Beam	0.03	0.08		0.06	0.07	0.08	0.03
Load case	#24	#14		#25	#16	#29	#24
Length	38*	76		76	76	76	38*
Min req'd	38*	76*		76*	76*	76*	38*
KB	1.00	1.00		1.00	1.00	1.00	1.00
KB min	1.00	1.00		1.00	1.00	1.00	1.00
KD	1.00	0.87		0.94	0.94	0.87	1.00

*Minimum bearing length for panels is 38 mm for exterior supports and 76 mm for intermediate supports

Nordic X-Lam Floor Panel Architectural, E1 143-5S 143 mm (1000 mm width)
 Supports: All - Non-wood
 Total length: 13.858 m; Clear span: 2, 3.9, 1.5, 4, 2.1 m; Volume = 1.982 m³; Panel orientation: Longitudinal axis
This section PASSES the design code check.

Limit States Design using CSA O86-14:

Criterion	Analysis Value	Design Value	Unit	Analysis/Design
Shear	Vf @d = 9.19	Vr = 27.95	kN	Vf/Vr = 0.33
Moment(+)	ME = 7.12	Mr = 58.05	kN-m	ME/Mr = 0.12
Moment(-)	ME = 8.86	Mr = 56.95	kN-m	ME/Mr = 0.16
Perm. Defl'n	1.9 = < L/999	11.3 = L/360	mm	0.17
Live Defl'n	1.2 = < L/999	11.3 = L/360	mm	0.11
Total Defl'n	5.1 = L/798	17.0 = L/240	mm	0.30
Vibration	Lmax = 4.070	Lv = 5.186	m	Lmax/Lv = 0.78

+ architectural details → **DA2**

+ structural details → **DS2**

+ installation guide → **GI2**

+ maintenance guide → **GE2**

+ product warranty → **N-X601**